



RAILROAD COMMISSION OF TEXAS

OIL AND GAS DIVISION

PERMIT TO GEOLOGIC STORAGE AND ASSOCIATED INJECTION OF ANTHROPOGENIC CARBON DIOXIDE (CO₂)

Oxy Low Carbon Ventures, LLC (P-5 # 100129)
 PO Box 4294
 Houston, TX 77210

Amended Permit

Class VI Permit Number: 59502
Project/Facility Name: Brown Pelican CO₂ Sequestration
County: Ector, District 08

Effective Date: xxxxxxxxxxxx

Expiration Date: Life of the project, if injection begins within five (5) years from the effective date; otherwise, a renewal application must be filed with a fee within 21 days before xxxxxxxxxxxx.

Authority is granted to inject **anthropogenic CO₂** into the wells identified herein in accordance with pursuant to the Texas Water Code, Chapter 27, the Texas Natural Resources Chapter 91, and Underground Injection Control (UIC) regulations of the Railroad Commission of Texas, codified at Title 16, Part 1, Chapter 5 of the Texas Administrative Code (16 TAC) Subchapters A and B, §§5.101, 5.102, 5.201, 5.202, 5.203, 5.204, 5.205, 5.206, 5.207, and 5.208, and based on information contained in the application, final version submitted on April 1, 2026, subject to the following terms and conditions:

TABLE 1: GENERAL INFORMATION

Source of CO ₂	Total CO ₂ Storage Mass (Million Metric Tons)	Duration of Injection (Years)	Top Confining Zone Formation Name	Injection Zone Formation Name
Direct Air Capture	9.11	12	Upper San Andres and Grayburg	Lower San Andres (G4, G1, Holt)

TABLE 2: INJECTION WELL IDENTIFICATION AND PERMIT PARAMETERS

Project Well Name & No. (Regulatory Well Name & No.)	API No.	UIC No.	Top Inj. Interval, TVD (Feet)	Bottom Inj. Interval, TVD (Feet)	Max. Injection Mass Rate (Metric tons per day)	Max. Surface Injection Pressure (psig)	Max. Bottom Hole Injection Pressure (psig)
BRP # CCS1 (Slant Well) (Shoe Bar Ranch # 1CS)	135-44040	000127399	4,462	5,156	1,040	2,342	3,362
BRP # CCS2 (Horiz. Well) (Shoe Bar Ranch # 2CS)	135-44041	000127400	4,464	5,117	1,196	3,202	4,111
BRP # CCS3 (Slant Well) (Shoe Bar Ranch # 3CS)	135-44062	000127401	4,398	5,085	676	1,568	2,830

TABLE 3: MONITOR WELL IDENTIFICATION

Project Well Name & No.	Regulatory Well Name & No.	API No.	Purpose	Total Depth, TVD (Feet)	Drill Date
SLR #1	Shoe Bar Ranch #1	135-43920	Upper Confining Zone Monitor	6,585; 4,067 ¹	2023
SLR #2	Shoe Bar Ranch #2SL	135-44065	Injection Zone Monitor	5,339	2025
SLR #3	Shoe Bar Ranch #3SL	NA	Injection Zone Monitor	5,316	~2030; ~5 years after commencement of CO ₂ injection
ACZ #1	Shoe Bar Ranch #1AZ	135-43977	Upper Confining Zone Monitor	6,725; 4,375 ¹	2023
USDW #1	Shoe Bar #1USDW	Water Well Report, Tr. No. 657173	Lowermost BUQW Monitor	850	2024
WW #1	Shoe Bar Ranch #1WW	135-44035	Water withdrawal, Injection Zone Monitor	5,219	2024
WW #2	Shoe Bar Ranch #2WW	135-44036	Water withdrawal, Injection Zone Monitor	5,416; ~ 4,980 ²	2024
WW #3	Shoe Bar Ranch #3WW	135-44037	Water withdrawal, Injection Zone Monitor	5,227	2024
WW #4	Shoe Bar Ranch #4WW	135-44034	Water withdrawal, Injection Zone Monitor	5,536	2024

¹Plugback depth following conversion to monitor well

²Anticipated TD following plugging above Holt zone

STANDARD CONDITIONS:

1. The operator must submit a proposed schedule at least **30 days** to District Office and notify at least **48 hours** prior to:
 - a. beginning any well completion, workover or remedial operation
 - b. conducting any required test, logging or surveys

All information and test results must be filed with SIP unit using the email SIP@rrc.texas.gov. and a copy to the District Office, which shall be signed and certified.

2. Before surface casing is installed, the operator must run appropriate logs, such as resistivity, spontaneous potential, and caliper logs.
3. After each casing string is set and cemented, the operator must run logs, such as a cement bond log, variable density log, and a temperature log, to ensure proper cementing.
4. Before long string casing is installed, the operator must run logs appropriate to geology, such as resistivity, spontaneous potential, porosity, caliper, gamma ray, and fracture finder logs, to gather data necessary to verify the characterization of the geology and hydrology.
5. Injection must be through tubing set on a packer. The packer must be set no higher than 100 feet above the top of the permitted interval.
6. The well must be constructed using CO₂ compatible materials.
7. The wellhead must be equipped with a pressure observation valve on the tubing and for annulus.
8. The well must use alarms and automatic shut-off systems designed to alert and shut-in the well when operating parameters such as annulus pressure, injection rate or other parameters diverge from permitted ranges.
9. The annulus between the tubing and the long string casing must be filled with a corrosion inhibiting fluid and must maintain on the annulus a pressure, that exceeds the operating injection pressure.

10. The total volume of CO₂ injected into the storage facility must be metered through a master meter. The volume and/or mass of CO₂ injected into each injection well must be metered through an individual well meter. If mass is determined using volume, the operator must provide calculations.
11. Prior to injection, whole cores or sidewall cores of the injection and confining zones; and formation fluid samples from the injection zone must be taken. Thereafter, a detailed report prepared by a log analyst that includes well log analyses, core analyses and formation fluid sample information such as temperature, pH, conductivity must be submitted.
12. Must provide the chemical composition and temperature of the CO₂ stream.
13. An annulus pressure test must be performed prior to injection and at least once **every five years** thereafter, or subsequently after any work over. The test pressure must equal the maximum authorized injection pressure or 500 psig, whichever is less, but must be at least 200 psig. The test results must be submitted in accordance with the instructions of **Form H-5** within **30 days** after the testing.
14. Prior to injection, the operator must perform an **initial** pressure fall-off or other test and submit a written report of the results of the test, including details of the methods used to perform the test and to interpret the results, all necessary graphs, and the testing log, to verify permeability, injectivity, and initial pressure using water or CO₂.
15. The injection pressure, rate, temperature, volume and/or mass, and the pressure on the annulus and annulus fluid volume added must be monitored **daily** and reported **semi-annually** on a monthly basis on Form H-10.
16. At least **once per year** until the injection well is plugged, the external mechanical integrity of the casing must be performed using a method approved by the director (e.g., diagnostic surveys such as oxygen-activation logging or temperature or noise logs). The results of the test, including details of the methods used to perform the test and to interpret the results, all necessary graphs, and the testing log must be submitted.
17. Within **30 days** after completion, a new Form W-2 and Log must be filed to show the current completion status of the well. The date of the injection well permit, and the permit number must be included on the new Form W-2.
18. Every **five years** or more frequently the AoR will be reevaluated, and the resultant information must be submitted in an electronic format.
19. The operator must submit an **annual report** detailing the re-calculated AOR unless the operator submits a statement signed by an appropriate company official confirming that monitoring and operational data supports the current delineation of the AOR on file with the Commission.
20. Injection fee. The operator must pay the Commission **an annual fee** of \$0.025 per metric ton of CO₂ injected into the geologic storage facility.
21. Post-injection care fee. The operator must pay the Commission **an annual fee** of \$50,000 for each year that the operator does not inject into the geologic storage facility until the director has authorized storage facility closure.
22. The operator may transfer the facility permit to another operator and must submit written notice of an intended permit transfer to the director at least **45 days** prior to the date the transfer of operations is proposed to take place.
23. The operator must identify each location in which geologic storage activities take place, including each injection well, with a sign that meets the requirements specified in §3.3(1), (2), and (5) of this title (relating to Identification of Properties, Wells, and Tanks). In addition, each sign must include a telephone number where the operator or a representative of the operator can be reached **24 hours a day, seven days a week** in the event of an emergency.
24. The operator of a geologic storage facility must comply with the requirements of Chapter 5, subchapter B as well as with all other applicable Commission rules and orders, including the requirements of Chapter 8 of this title (relating to Pipeline Safety Regulations) for pipelines and associated facilities.
25. Within **30 days** of receipt of this permit, the permittee shall certify to the Director in an electronic format, that the operator has read and is familiar with all terms and conditions of this permit. This certification shall be signed and made in accordance with requirements of Title 16 TAC §5.207(c) and (d).
26. The permittee may not commence injection until the Director has given a **written authorization** to commence injection.

SPECIAL CONDITIONS:

1. The packer setting depth was approved for BRP #CCS1 at 390 feet TVD above the top of the injection interval, and for BRP #CCS3 at 605 feet above the top of the injection interval.
2. Injection cannot begin until a **letter of credit** in an amount of **\$ 18,045,089.12** has been filed. The letter of credit must be renewed and continued in effect until the conditions of the letter of credit have been met or its release is authorized. An **annual** update of the cost estimate to increase or decrease to account for any changes must be provided within **60 days** prior to the anniversary date of the establishment of the financial instruments used to comply. Whenever the current cost estimate increases or decreases, the face amount of the financial assurance instrument may be increased or reduced to the amount of the current cost estimate.

Provided further that, should it be determined that such injection fluid is not confined to the approved interval, then the permission given herein is suspended and the injection operation must be stopped until the fluid migration from such interval is eliminated. Failure to comply with all the conditions of this permit may result in the operator being referred to enforcement to consider assessment of administrative penalties and/or the cancellation of the permit.

APPROVED AND ISSUED ON xxxxxxxxxx

Rob Castillo, Manager
Special Injection Permits Unit

Amendment Comments:

Amends permit dated October 16, 2025

Parameter/ Condition	BRP CCS1: Original Permit Value	BRP CCS2: Original Permit Value	BRP CCS3: Original Permit Value	BRP CCS1: Updated Permit Value	BRP CCS2: Updated Permit Value	BRP CCS3: Updated Permit Value	Units
Daily maximum injection mass	600	1,500	600	1,040	1,196	676	Metric tons per day
Daily average injection mass	450	1,112	450	572	1,040	468	Metric tons per day
Daily maximum injection rate	8.2	25	9.0	20	23	13	Million standard cubic feet per day
Daily average injection rate	7.9	21.9	8.1	11	20	9	Million standard cubic feet per day
Total mass	1.83	4.87	1.77	2.50	4.55	2.05	Million metric tons
Maximum injection mass	166,000	481,000	166,000	379,466	436,386	246,653	Metric tons per year
Average injection mass	153,000	406,000	153,000	208,706	379,466	170,760	Metric tons per year
Maximum surface wellhead injection pressure	1,100	1,800	1,100	2,342	3,202	1,568	psig
Maximum bottomhole injection pressure	2,625.30	3,391.80	2,625.30	3,362	4,111	2,830	psig

Class VI Permit Condition & Details

DRAFT

Table of Contents

A.	EFFECT OF PERMIT	9
B.	PERMIT ACTIONS	9
1.	Modification, Revocation and Reissuance, and Termination	9
2.	Minor Modifications	9
3.	Transfer of Permit	9
C.	SEVERABILITY	9
D.	CONFIDENTIALITY	10
E.	DEFINITIONS	10
F.	DUTIES AND REQUIREMENTS	10
1.	Prohibition of Movement of Fluid into a USDW	10
2.	Duty to Comply	10
3.	Duty to Reapply	10
4.	Penalties for Violations of Permit Conditions	10
5.	Need to Halt or Reduce Activity Not a Defense	11
6.	Duty to Mitigate	11
7.	Proper Operation and Maintenance	11
8.	Duty to Provide Information	11
9.	Inspection and Entry	11
10.	Signatory and Certification Requirements	11
G.	AREA OF REVIEW AND CORRECTIVE ACTION	12
H.	FINANCIAL RESPONSIBILITY	13
1.	Costs to be Covered	13
2.	Cost Estimate Updates and Adjustments	13
3.	Notification	13
I.	WELL CONSTRUCTION	14
1.	Injection Well Construction	14
2.	Siting	15
3.	Casing and Cementing	15
4.	Tubing and Packer Specifications	15
5.	Sampling and Monitoring Devices	16
6.	Construction of Monitoring Well	16
J.	PRE-INJECTION TESTING	16
K.	INJECTION WELL OPERATING REQUIREMENTS	17
1.	Outermost Casing Injection Prohibition	17
2.	Injection Fluids/Carbon Dioxide Sources	17
3.	Injection Pressure Limitation	18
4.	Stimulation Program	18

5.	Additional Injection Limitations.....	18
6.	Annulus Fluid	18
7.	Annulus/Tubing Pressure Differential	18
8.	Automatic Alarms and Automatic Shut-off System	18
9.	Precautions to Prevent Well Blowouts	19
10.	Circumstances Under Which Injection Shall Cease.....	19
11.	Approaches for Ceasing Injection	19
L.	MECHANICAL INTEGRITY	20
1.	Standards.....	20
2.	Mechanical Integrity Testing	20
3.	Prior Notice, MIT Procedures and Reporting	21
4.	Gauge and Meter Calibration.....	22
5.	Loss of Mechanical Integrity	22
6.	Mechanical Integrity for Monitoring Wells	23
7.	Mechanical Integrity Testing on Request from Director	23
M.	SEISMIC EVENT RESPONSE	23
1.	Seismic Monitoring.....	23
2.	Seismic events not recorded or M less than 2.0	24
3.	Seismic events with M equal to or greater than 2.0 but less than 3.5.....	24
4.	Seismic Events with M equal to or greater than 3.5.....	24
N.	TESTING AND MONITORING REQUIREMENTS	24
1.	Testing and Monitoring Plan	24
2.	Carbon Dioxide Stream Analysis	25
3.	Continuous Monitoring.....	25
4.	Groundwater (USDW) Monitoring Above the Confining Zone	25
5.	Soil & Soil Gas Sampling.....	26
6.	Carbon Dioxide Plume and Pressure Front Tracking	26
7.	Corrosion Monitoring.....	26
8.	External Mechanical Integrity Testing	26
9.	Pressure Fall-Off Test.....	26
10.	Additional Monitoring	26
O.	REPORTING AND RECORDKEEPING	26
1.	Electronic Reporting.....	27
2.	Semi-Annual Reports.....	27
3.	Twenty-Four (24)-Hour Reporting	28
4.	Reports on Well Tests and Workovers	28
5.	Advance Notice Reporting	29
6.	Additional Reports.....	29

7.	Records and Record Retention.....	30
P.	WELL PLUGGING, POST-INJECTION SITE CARE, AND SITE CLOSURE	30
1.	Well Plugging Plan Revisions	31
2.	Required Activities Prior to Plugging.....	31
3.	Notice of Plugging and Abandonment	31
4.	Plugging and Abandonment Approval and Report.....	31
5.	Temporary Abandonment	31
6.	Post-Injection Site Care and Site Closure Plan	32
Q.	EMERGENCY AND REMEDIAL RESPONSE.....	33
R.	COMMENCING INJECTION.....	34
S.	PAYMENT OF FEES TO THE STATE OF TEXAS.....	35
1.	Application Fee for Amendment.....	35
2.	Injection Fee	35
3.	Post-Injection Care Fee	35
	ATTACHMENTS.....	36

DRAFT

PERMIT CONDITIONS

A. EFFECT OF PERMIT

The permittee is allowed to engage in underground injection in accordance with the conditions of this permit. Notwithstanding any other provisions of this permit, the permittee authorized by this permit shall not construct, operate, maintain, convert, plug, abandon, or conduct any other injection activity in a manner that allows the movement of injection, annulus, or formation fluids into underground sources of drinking water (USDW) or any unauthorized geologic zones. The objective of this permit is to prevent the movement of fluids into or between USDW or into any unauthorized geologic zones consistent with the requirements of **16 TAC §§5.203(d)(1)(C), 5.203(e)(1)(A)(i) and 5.203(j)(2)(H)**. Any underground injection activity not specifically authorized in this permit is prohibited. For purposes of enforcement, compliance with this permit during its term constitutes compliance with Texas Water Code, Chapter 27, and the Texas Natural Resources Code, Chapter 91. Issuance of this permit does not convey property rights of any sort or any exclusive privilege; nor does it authorize any injury to persons or property, any invasion of other private rights, or any infringement of State or local laws or regulations. Nothing in this permit shall be construed to relieve the permittee of any duties under applicable regulations.

B. PERMIT ACTIONS

1. Modification, Revocation and Reissuance, and Termination – The Director of the RRC Class VI UIC Program, hereinafter, the Director, may, for cause or upon request from any interested person, including the permittee, modify, revoke and reissue, or terminate this permit in accordance with **16 TAC §5.202(d)(2)(A)**. The filing of a request for a permit modification, revocation and reissuance, or termination, or notification of planned changes, or anticipated noncompliance on the part of the permittee does not stay the applicability or enforceability of any permit condition in accordance with **16 TAC §5.206(o)(2)(K)**.

2. Minor Modifications – Upon the consent of the permittee, the Director may modify a permit to make the corrections or allowances for minor changes in the permitted activity as listed in **16 TAC §5.202(d)(2)(A)(viii)**. Any permit modification not processed as a minor modification under **16 TAC §5.202(d)(2)(A)(viii)** shall be made for cause, and with a draft permit and public notice as required in **16 TAC §5.204**.

3. Transfer of Permit – An operator may transfer its geologic storage facility permit to another operator if the requirements of **16 TAC §5.202(c)** are met. A new operator shall not assume operation of the geologic storage facility without a valid permit in accordance with **16 TAC §5.202(c)** and Section O(6)(b) of this permit.

C. SEVERABILITY

The provisions of this permit are severable under **16 TAC §5.208(b)**, and if any provision of this permit or the application of any provision of this permit to any circumstance is held invalid, the application of such provision to other circumstances and the remainder of this permit shall not be affected thereby.

D. CONFIDENTIALITY

In accordance with the Texas Public Information Act, Texas Government Code, Chapter 552, any information submitted to the RRC pursuant to this permit may be claimed as confidential business information by the submitter. Any such claim shall be asserted at the time of submission by clearly identifying each page with the words "confidential business information" on every page containing such information. If no claim is made at the time of submission, the RRC may make the information available to the public without further notice. If a claim is asserted, the validity of the claim will be assessed in accordance with the procedures in the Texas Public Information Act, Texas Government Code, Chapter 552. Claims of confidentiality for the following information will be denied:

1. The name and address of the permittee; and
2. Information which deals with the existence, absence, or level of contaminants in drinking water.

E. DEFINITIONS

All terms used in this permit shall have the meaning set forth in the Texas Water Code, Chapter 27, or the Texas Natural Resources Code, Chapter 91, and the RRC's UIC regulations specified at **16 TAC §5.102**. Unless specifically stated otherwise, all references to "days" in this permit should be interpreted as calendar days.

F. DUTIES AND REQUIREMENTS

- 1. Prohibition of Movement of Fluid into a USDW** – The permittee shall not construct, operate, maintain, convert, plug, abandon, or conduct any other injection activity in a manner that allows the movement of a fluid containing any contaminant into USDWs. If any water quality monitoring of a USDW indicates the movement of any contaminant into the USDW, the Director may take enforcement action or prescribe such additional requirements for construction, corrective action (including closure of the injection well), operation, monitoring, or reporting as are necessary to remediate and prevent such movement.
- 2. Duty to Comply** – The permittee shall comply with all conditions of this permit. Any permit noncompliance constitutes a violation of **16 TAC §5.206(o)(2)(A)** and is grounds for enforcement action, permit termination, revocation and reissuance, modification, or for denial of a permit renewal application.
- 3. Duty to Reapply** – If the permittee wishes to continue an activity regulated by this permit after its expiration, the permittee shall apply for and obtain a new permit.
- 4. Penalties for Violations of Permit Conditions** – Any person who violates a permit requirement is subject to civil and/or criminal penalties and other enforcement action under the Texas Natural Resources Code, Title 3, Section 91.143 and Texas Water Code, Chapter 27. Any person who willfully violates permit conditions may be subject to criminal prosecution under the Texas Natural Resources Code, Title 3, Section 91.143 and Texas Water Code, Chapter 27.

5. Need to Halt or Reduce Activity Not a Defense – It shall not be a defense for the permittee in an enforcement action to claim that it would have been necessary to halt or reduce the permitted activity to maintain compliance with the conditions of this permit in accordance with **16 TAC §5.206(o)(2)(B)**.

6. Duty to Mitigate – The permittee shall take all timely and reasonable steps necessary to minimize or correct any adverse impact on the environment resulting from noncompliance with this permit in accordance with **16 TAC §5.206(o)(2)(C)**.

7. Proper Operation and Maintenance – The permittee shall at all times properly operate and maintain all facilities and systems of treatment and control and related appurtenances which are installed or used by the permittee to achieve compliance with the conditions of this permit. Proper operation and maintenance include, among other things, effective performance, adequate funding, adequate operator staffing and training, and adequate laboratory and process controls, including appropriate quality assurance procedures. This provision requires the operation of back-up or auxiliary facilities or similar systems only when necessary to achieve compliance with the conditions of this permit in accordance with **16 TAC §5.206(o)(2)(D)**.

8. Duty to Provide Information – The permittee shall furnish to the Director in electronic format, within the time specified by the type of submittal or as defined by the Director, any information which the Director may request to determine whether cause exists for modifying, revoking and reissuing, or terminating this permit, or to determine compliance with this permit or the UIC regulations. The permittee shall also furnish to the Director, upon request, within a time specified, electronic copies of records required to be kept by this permit in accordance with **16 TAC §5.206(o)(2)(H)**.

9. Inspection and Entry – The operator shall allow any member or employee of the Commission, on proper identification, to by **16 TAC §5.206(o)(2)(I)**:

- (a) Enter upon the permittee's premises where a regulated facility or activity is located or conducted, or where electronic or non-electronic records are kept under the conditions of this permit.
- (b) Have access to and copy, at reasonable times, any electronic or non-electronic records that are kept under the conditions of this permit.
- (c) Inspect, at reasonable times, any facilities, equipment (including monitoring and control equipment), practices, or operations regulated or required under this permit; and
- (d) Sample or monitor, at reasonable times, for the purposes of assuring permit compliance or as otherwise authorized by the Texas Water Code, §27.071, or the Texas Natural Resources Code, §91.1012, any substances or parameters at any location, including facilities, equipment or operations regulated or required under this permit.

10. Signatory and Certification Requirements – All reports, notifications, or any other information, required to be submitted by this permit or requested by the Director shall

be signed and certified in accordance with **16 TAC §§5.206(o)(2)(L), 5.207(c) and 5.207(d)**.

G. AREA OF REVIEW AND CORRECTIVE ACTION

- 1.** The Area of Review (AoR) is the area surrounding the injection well where USDWs may be endangered by the injection activity. The area of review was delineated using computational modeling that accounts for the physical and chemical properties of all phases of the injected carbon dioxide stream and is based on available site characterization, monitoring, and operational data. The permittee shall maintain and comply with the approved AoR and Corrective Action Plan (CAP) included as Attachment A, which is an enforceable condition of this permit, and shall meet the requirements of **16 TAC §5.206(g)**.
- 2.** As documented in Attachment A of the Original Class VI Special Injections Permit No. 55294, which became effective on October 16, 2025, three (3) wellbore penetrations within the AoR required plugging because these wellbores penetrate the injection zone or confining layer and were not going to be used for injection or monitoring within the Brown Pelican CO₂ Sequestration Project. These three wells (listed below) have subsequently been plugged and abandoned by the permittee, and these operations were witnessed by a Texas Railroad Commission District 08 (Midland Office) Well Inspector. Documentation of the final completed Corrective Action activities on these wells has been submitted to the Director by the permittee:
 - (a) The Eidson E Well No. 1 (API No. 4213531130) was permanently plugged and abandoned in 2025, following the prescribed re-entry and plugging procedures documented in the original permit AoR and Corrective Action Plan (Attachment A).
 - (b) The Scharbauer Eidson Well No. 1 (API No. 4213510667) was permanently plugged and abandoned in 2025, following the prescribed re-entry and plugging procedures documented in the original permit AoR and Corrective Action Plan (Attachment A) and
 - (c) The Scharbauer Eidson Well No. 101 (API No. 4213506139) was permanently plugged and abandoned in 2025, following the prescribed re-entry and plugging procedures documented in the original permit AoR and Corrective Action Plan (Attachment A).
- 3.** Every five (5) years as specified in the AoR and CAP, or more frequently when monitoring and operational conditions warrant, the permittee shall reevaluate the AoR and perform corrective action in the manner specified in **16 TAC §5.206(g)** and update the AoR and CAP or demonstrate to the Director that no update is needed. Reevaluation of the AoR and CAP shall meet the requirements of **16 TAC §5.203(d)(1)(A) - (C)** and shall include a new survey of wells within the existing or modified AoR.
- 4.** Following each AoR reevaluation or a demonstration that no evaluation is needed, the permittee shall submit a report of the resultant information in an electronic format to the Director for review and approval. Once approved by the Director, the revised AoR and CAP will become an enforceable condition of this permit.

H. FINANCIAL RESPONSIBILITY

The permittee shall maintain financial responsibility and resources to meet the requirements of **16 TAC §5.205** for the life of this permit and through all phases of the project. The permittee must maintain financial responsibility until site closure is authorized by the Director as described in Section P of this permit. The permittee shall use financial instruments as listed in **16 TAC §5.205(c)(2)(D)** to cover all costs associated with the requirements of this permit. The approved financial responsibility and estimated costs for this permit are found in Attachment J and in the administrative record of this permit.

1. Costs to be Covered – The financial instrument(s) shall be sufficient to cover the cost of:

- (a) Corrective action (that meets the requirements of **16 TAC §5.203(d)(2)**).
- (b) Injection well plugging (that meets the requirements of **16 TAC §5.203(k)**).
- (c) Emergency and remedial response (that meets the requirements of **16 TAC §5.203(l)**).
- (d) Post injection site care and site closure (that meets the requirements of **16 TAC §5.206(m)**).

2. Cost Estimate Updates and Adjustments – A detailed written estimate for each phase is included in Attachment J of this permit. The cost estimates must be performed for each phase separately and must be based on the costs to the Commission of hiring a third party to perform the required activities. A third party is a party who is not within the corporate structure of the owner or operator, and the dollar amount of the financial assurance shall be approved by the Director in accordance with **16 TAC §5.205(c)(2)(C)(i)**.

- (a) A qualified professional engineer licensed by the State of Texas, as required under Occupations Code, Chapter 1001, relating to Texas Engineering Practice Act, must prepare or supervise the preparation of a written estimate of the highest likely amount necessary to close the geologic storage facility. The owner or operator must submit to the director the written estimate under seal of a qualified licensed professional engineer, as required under Occupations Code, Chapter 1001, relating to Texas Engineering Practice Act in accordance with **16 TAC §5.205(c)(2)(C)(ii)**.
- (b) During the life of this permit, the permittee shall adjust the cost estimate for annual inflation and any amendments made to the Project Plans included as Attachments A-J of this permit, which address costs associated with items (a) through (d) in Section H(1) of this permit. The permittee shall adjust cost estimates annually at least 60 days prior to the anniversary date of the establishment of the financial instrument(s) and provide this adjustment to the Director in an electronic format in accordance with **16 TAC §5.205(c)(2)(E)**. All cost and Project Plan adjustments are subject to the Director's approval.

3. Notification –

- (a) Whenever a cost estimate increases to an amount greater than the face amount of a controlling financial instrument, the permittee, at least 60 days after the increase,

shall either cause the face amount to be increased to an amount at least equal to the current cost estimate and submit evidence of such increase to the Director, or obtain other financial responsibility instruments to cover the increase. Whenever a current cost estimate decreases to an amount less than the face amount of a controlling financial instrument, the face amount of the financial assurance instrument may be reduced to the amount of the current cost estimate only after the permittee has received written approval from the Director in accordance with **16 TAC §5.205(c)(2)(G)**.

(b) The permittee shall notify the Director by certified mail and in an electronic format of adverse financial conditions that may affect the ability to carry out injection well plugging, post-injection site care and site closure, and any applicable ongoing actions under Corrective Action and/or Emergency and Remedial Response. The notice of bankruptcy shall be filed in accordance with **16 TAC §§3.1(f)** (relating to Organization Report; Retention of Records; Notice Requirements) and **5.205(d)(1)**. Such notice shall be provided to the RRC's Office of General Counsel and to the Director.

- (i) The owner or operator filing a bond must ensure that the bond provides a mechanism for the bond or surety company to give prompt notice to the Commission and the owner or operator of any action filed alleging insolvency or bankruptcy of the surety company or the bank or alleging any violation that would result in suspension or revocation of the surety or bank's charter or license to do business in accordance with **16 TAC §5.205(d)(2)**.
- (ii) Upon the incapacity of a bank or surety company by reason of bankruptcy, insolvency or suspension, or revocation of its charter or license, the Commission must deem the owner or operator to be without bond coverage in accordance with **16 TAC §5.205(d)(3)**. The Commission must issue a notice to any owner or operator who is without bond coverage and must specify a reasonable period to replace bond coverage, not to exceed 60 days.

I. WELL CONSTRUCTION

The design and specifications for the injection well, injection zone monitoring wells, confining zone monitoring wells, and the USDW monitoring wells are included in Attachment B of this permit.

1. Injection Well Construction – The wells shall be constructed in accordance with **16 TAC §§3.13** and **5.203(e)(1)**. The design and construction shall allow continuous monitoring of the annulus between the long string casing and the injection tubing and accommodate testing devices and workover tools. During construction, the permittee may make changes to the design of the injection well consistent with the conditions of this permit. If changes are made to the design of the well, notification shall be made to the Director, and the construction changes shall be provided for review and approval by the Director before installation. Once the construction of the well is completed, and prior to authorization to inject, the permittee shall submit the final, as-built construction specifications and diagrams within 30 days for review and approval by the Director. Any deviations from the proposed design and as-built construction of the well shall be noted. If

the changes in well design are significant, the Director may require this permit to be modified.

- 2. Siting** – The permittee has demonstrated to the satisfaction of the Director that the well is in an area with suitable geology in accordance with the requirements at **16 TAC §5.206(b)(6)**.
- 3. Casing and Cementing** – The wells shall be cased and cemented in accordance with **16 TAC §§3.13 and 5.203(e)(1)(B)**. Casing, cement, or other materials used in the construction of the well shall have sufficient structural strength for the life of the geologic sequestration project. All well materials shall be compatible with all fluids with which the materials may be expected to come into contact and shall meet or exceed standards developed for such materials by the American Petroleum Institute, ASTM International, or comparable standards acceptable to the Director. The casing and cementing program shall prevent the movement of fluids into or between USDWs for the expected life of the well. The casing and cement used in the construction of this well are shown in Attachment B of this permit and in the administrative record for this permit. Any changes shall be submitted in an electronic format for approval by the Director before installation.
- 4. Tubing and Packer Specifications** – The tubing and packer design shall meet the requirements of **16 TAC §§3.13 and 5.203(e)**. Tubing and packer materials used in the construction of the well shall be compatible with fluids with which the materials may be expected to come into contact and shall meet or exceed standards developed for such materials by the American Petroleum Institute, ASTM International, or comparable standards acceptable to the Director. Injection shall only take place through the tubing, with a packer set in the long string casing within or below the nearest cemented and impermeable confining system. The tubing and packer used in the well are represented in engineering drawings contained in Attachment B of this permit. Any change shall be submitted in an electronic format for review and approval by the Director before installation. The BRP # CCS1 injection well was drilled and constructed with the perforated injection casing situated at a specific hole-angle of approximately 48.6 degrees from true vertical. The BRP # CCS3 injection well was drilled and constructed with the perforated injection casing situated at a specific hole-angle of approximately 59.8 degrees from true vertical. **16 TAC §5.203 (e) (C)(i)** states: *Packers must be set no higher than 100 feet above the top of the permitted injection interval or at a location approved by the director.* Setting an injection packer not more than 100 feet above the uppermost perforations of the injection interval in the specific instances of either the BRP # CCS1 or BRP # CCS3 injection wells, would require setting the injection packers in relatively high-angle inclined sections of these wellbores. Well intervention and logging will be required several times throughout the life of each of these wells and setting an injection packer at wellbore inclinations greater than 30 degrees will make these subsequent well interventions and logging operations technically challenging, especially trying to pass downhole equipment on wireline through the installed landing nipple above each packer. Given these circumstances, the operator has requested and the Director has granted an injection-packer setting-depth variance for construction of the BRP # CCS1 and BRP # CCS3 wells. This variance allows the injection packer to be set more than 100 feet TVD above the top of the injection interval in each of these two higher-angle inclined wellbores. Under this injection-packer setting-depth variance, the injection packer in the BRP # CCS1 will be set approximately 390 feet TVD above the top

of the injection interval, and the injection packer in the BRP # CCS3 will be set approximately 605 feet TVD above the top of the injection interval.

5. Sampling and Monitoring Devices – The permittee shall install and maintain in good condition all devices required to measure, monitor, and record the data required by Attachment F of this permit. The permittee shall ensure that the devices installed and methods used are sufficient to represent the activity being measured, monitored, or recorded. Calculated flow data or periodic monitoring are not acceptable for required continuous monitoring except as a back-up system if the primary continuous monitoring devices become inoperable. The Director shall be notified of such occurrences, and continuous monitoring devices should be repaired or replaced as soon as practicable. If this period of time is extensive in the opinion of the Director, injection activities shall cease until such time that normal monitoring is restored. The permittee shall ensure the wells' construction and near-wellhead design is appropriate for the collecting of samples and fulfilling of all monitoring requirements of this permit. The permittee shall ensure all gauges used for monitoring and testing are properly calibrated.

6. Construction of Monitoring Well – **16 TAC §§5.203(j)(2)(D)(i), 5.203(j)(2)(D)(ii), 5.203(j)(2)(E), and 5.203(j)(2)(G)** require monitoring of the carbon dioxide plume and pressure front of the confining and injection zones and monitoring of USDW located above the injection zone. These sections are incorporated by reference into this permit. USDW, confining zone, and injection zone monitoring wells shall be constructed in the manner depicted in Attachment B of this permit using materials that are compatible with the injected fluids. All monitoring wells shall be constructed in a manner to provide representative samples that can be analyzed for the monitoring parameters required by this permit. Once the construction of the monitoring wells has been completed, the as-built construction diagrams shall be included in the Pre-injection Testing Report to be submitted to the Director per Section J of this permit.

J. PRE-INJECTION TESTING

Testing is required during the construction of the well in accordance with **16 TAC §5.203(f)**. This testing is required to verify the geology of the well site to ensure compliance with the well construction requirements in accordance with **16 TAC §5.203(e)** and to test viability of the wells to meet the stipulated operational requirements. The pre-injection testing plan is included as Attachment D of this permit.

1. Prior to the Director authorizing injection, the permittee shall perform all pre-injection logging, sampling, and testing specified at **16 TAC §5.203(f)**. This testing shall include:

(a) Logs, surveys and tests to determine or verify the depth, thickness, porosity, permeability, lithology, and formation fluid salinity in all relevant geologic formations. These tests shall include:

(i) Deviation checks that meet the requirements of **16 TAC §5.203(f)(1)(A)**.

(ii) Logs and tests before and upon installation of the surface casing that meet the requirements of **16 TAC §5.203(f)(1)(B)**.

- (iii) Logs and tests before and upon installation of the long-string casing that meet the requirements of **16 TAC §5.203(f)(1)(D)**.
 - (iv) Tests to demonstrate internal and external mechanical integrity that meet the requirements of **16 TAC §5.203(h)** and
 - (v) Any alternative methods (MIT), provided that the type of test has the written approval of the Administrator pursuant to requirements at **16 TAC §5.203(h)(2)(E)**.
- (b) Documentation of the measured fluid temperature, pH, conductivity, reservoir pressure, and static fluid level of the injection zone that meet the requirements of **16 TAC §5.203(f)(3)(A)**.
 - (c) Whole cores or sidewall cores of the injection zone and confining system and formation fluid samples from the injection zone that meet the requirements of **16 TAC §5.203(f)(3)(B)**.
 - (d) Tests to determine well-specific data regarding the injection and confining zones. These tests shall determine fracture pressure and the physical and chemical characteristics of the injection and confining zones and the formation fluids in the injection zone that meet the requirements of **16 TAC §§5.203(f)(2)(C)** and **5.203(f)(3)(B)**.
 - (e) Tests to verify hydrogeologic characteristics of the injection zone that meet the requirements of **16 TAC §5.203(f)(2)**, including:
 - (i) A pressure fall-off test or
 - (ii) Other test and submit to the director a written report of the results of the test, including details of the methods used to perform the test and to interpret the results, all necessary graphs, and the testing log, to verify permeability, injectivity, and initial pressure using water or CO₂.
- 2.** The permittee shall submit to the Director for approval in an electronic format a schedule for pre-operational testing activities 30 days prior to conducting the first test and submit any changes to the schedule 30 days prior to the next scheduled test. The permittee shall provide the Director with the opportunity to witness all logging, sampling, and testing required under this permit and submit notice at least 48 hours in advance of any actual activity in accordance with **16 TAC §5.206(i)**.

K. INJECTION WELL OPERATING REQUIREMENTS

- 1. Outermost Casing Injection Prohibition** – Injection between the outermost casing protecting USDWs and the well bore is prohibited.
- 2. Injection Fluids/Carbon Dioxide Sources** – The permittee will capture carbon dioxide from one source during the life of the permit for injection into the Class VI wells. The source of carbon dioxide approved for injection is the Direct Air Capture facility located on a 65-acre site approximately 35 miles west of Odessa in Ector County. The permittee

may propose additional sources of carbon dioxide for injection, subject to review and approval by the Director.

- 3. Injection Pressure Limitation** – Except during stimulation, the permittee shall ensure that injection pressure does not exceed 90 percent of the fracture pressure of the injection zone(s) to ensure that the injection does not initiate new fractures or propagate existing fractures in the injection zone(s). Under no circumstance shall injection pressure initiate fractures or propagate existing fractures in the confining zone or cause the movement of injection or formation fluids into a USDW. The maximum injection pressure limit is listed in Attachment E of this permit.
- 4. Stimulation Program** – All stimulation activities shall be approved by the Director prior to conducting the stimulation. The permittee shall carry out the Stimulation Program in accordance with Attachment C of this permit.
- 5. Additional Injection Limitations** – No injection fluid other than that identified on Page 1 of this permit may be injected except fluids used for stimulation, rework, and well tests as approved by the Director. Injection shall occur within the injection tubing.
- 6. Annulus Fluid** – The permittee shall fill the annulus between the tubing and the long string casing with a non-corrosive fluid approved by the Director.
- 7. Annulus/Tubing Pressure Differential** – Except during workovers or times of annulus maintenance, the permittee shall maintain pressure on the annulus that exceeds the operating injection pressure as specified in Attachment E of this permit, unless the Director determines that such requirement might harm the integrity of the well or endanger USDW.
- 8. Automatic Alarms and Automatic Shut-off System** –
 - (a) The permittee shall:
 - i. Install, continuously operate, and maintain an automatic alarm and automatic shut-off system or, at the discretion of the Director, down-hole shut-off systems, or other mechanical devices that provide equivalent protection; and
 - ii. Successfully demonstrate the functionality of the alarm system and shut-off system prior to the Director authorizing injection, and at a minimum of once every twelfth month after the last approved demonstration.
 - iii. Establish well-specific thresholds for activating the shut-off system and submit revised Attachments E & H.
 - (b) Testing under this Section shall involve subjecting the system to simulated failure conditions and shall be witnessed by the Director or the Director's representative unless the Director authorizes an unwitnessed test in advance. The permittee shall provide notice in an electronic format at least 30 days prior to running the test and shall provide the Director or the Director's representative with the opportunity to witness the test. The test shall be documented using either a mechanical or digital device which records the value of the parameter of interest, or by a service

company job record. A final report including any additional interpretation necessary for evaluation of the testing shall be submitted to the Director in an electronic format within the time period specified in Section O(4) of this permit.

9. Precautions to Prevent Well Blowouts – Except at specific times as approved by the Director, the permittee shall maintain on the well a pressure which will prevent the return of the injection fluid to the surface. The wellbore shall be filled with a fluid of sufficient specific gravity during workovers to maintain a positive (downward) pressure gradient and/or a plug shall be installed which can resist the pressure differential. A blowout preventer shall be installed and kept in proper operational condition whenever the wellhead is removed to work on the well. The permittee shall follow procedures such as those below to ensure that a backflow or blowout does not occur:

- (a) Limit the temperature and/or corrosivity of the injectate; and
- (b) Develop procedures necessary to ensure that pressure imbalances do not occur.

10. Circumstances Under Which Injection Shall Cease – Injection shall cease when any of the following circumstances arises:

- (a) Failure of the well to pass a mechanical integrity test;
- (b) A loss of mechanical integrity during operation;
- (c) The automatic alarm or automatic shut-off system is triggered;
- (d) A significant unexpected change in the annulus or injection pressure;
- (e) The Director determines that the well lacks mechanical integrity;
- (f) Movement of injection or formation fluids outside of the current, approved injection interval is detected;
- (g) Conditions described in Section M(C)(3), Seismic Event Response, occur;
- (h) The Director determines the site is no longer suitable for injection based on new information;
- (i) The Director determines that the permittee is unable to maintain compliance with any condition of this permit or regulatory requirement, and the Director determines that injection should cease.

11. Approaches for Ceasing Injection –

- (a) In all instances where injection ceases, the permittee shall immediately cease injection and shut-in the well as outlined in the Emergency and Remedial Response Plan (Attachment H of this permit), and the Permittee must get approval from the Director to resume injection.
- (b) If an automatic shutdown (i.e., down-hole or at the surface) is triggered, the

Permittee must immediately investigate and identify the cause of the shutdown as expeditiously as possible. If, upon investigation, the well appears to lack mechanical integrity, or if the required monitoring of data from continuous recording devices or automatic shutoff systems indicates that the well may lack mechanical integrity, the Permittee must take the actions listed below in Section L of this Permit.

L. MECHANICAL INTEGRITY

The injection wells shall maintain internal (casing, tubing and packer) and external (fluid movement into geologic units other than the injection zone) mechanical integrity for the entirety of its operational life. No significant leaks in the casing, tubing, or packer can occur without corrective actions. The determination of whether the injection well has mechanical integrity is at the discretion of the Director. Mechanical integrity is determined through testing and test procedures approved by the Director. Approved mechanical integrity testing procedures are in the Testing and Monitoring Plan in Attachment F of this permit. Other tests and/or procedures not listed in this plan will be considered by the Director for approval.

1. Standards – Other than during periods of well workover (repair or maintenance) approved by the Director in which the sealed tubing-casing annulus is disassembled for maintenance or corrective procedures, the injection well shall have and maintain mechanical integrity consistent with **16 TAC §5.203(h)**. To meet these requirements, mechanical integrity tests/demonstrations shall be witnessed by the Director or an authorized representative of the Director unless prior approval has been granted by the Director to run an un-witnessed test. In order to conduct testing without a RRC representative, the following procedures shall be followed:

- (a) The permittee shall submit prior notification in an electronic format at least 30 days prior to testing, including the information that no RRC representative is available, and receive permission from the Director to proceed.
- (b) The test shall be performed in accordance with the Testing and Monitoring Plan (Attachment F of this permit) and documented using either a mechanical or digital device that records the value of the parameter of interest and
- (c) A final report including any additional interpretation necessary for evaluation of the testing shall be submitted in an electronic format within the time period specified in Section O(4) of this permit.

2. Mechanical Integrity Testing – The permittee shall conduct a casing inspection log and mechanical integrity testing (MIT) as follows:

- (a) After construction, and prior to receiving authorization to inject from the Director, the permittee shall demonstrate internal mechanical integrity of the well. This demonstration is achieved by the performance of the following testing pursuant to **16 TAC §5.203(h)(2)**:
 - (i) A pressure test with liquid or gas.
 - (ii) A casing inspection log or

- (iii) An alternative approved by the Director that has been approved by the Administrator pursuant to requirements at **16 TAC §5.203(h)(2)(E)**.
- (b) Prior to receiving authorization to inject, the permittee shall perform the following testing to demonstrate external mechanical integrity pursuant to **16 TAC §5.203(h)(2)**:
 - (i) Tracer surveys such as an oxygen activation log.
 - (ii) Temperature or noise logs.
 - (iii) An alternative approved by the Director that has been approved by the Administrator pursuant to requirements at **16 TAC §5.203(h)(2)(E)**.
- (c) Other than during periods of well workover (repair or maintenance) approved by the Director, in which the sealed tubing-casing annulus is disassembled for maintenance or corrective procedures, the permittee shall continuously monitor injection pressure, injection rate, injection mass, pressure on the annulus between tubing and long string casing, and annulus fluid volume as specified in **16 TAC §§5.203(h)(1)(C) and 5.206(e)(2)**.
- (d) At least once per year, the permittee shall perform the testing to demonstrate external mechanical integrity pursuant to **16 TAC §5.203(h)(1)(D)** and as listed in Section L(2)(b) of this permit. All test data shall be sent to SIP@rrc.texas.gov and a copy to District Director.
- (e) After any well repair or workover that may compromise the internal mechanical integrity of the well, the internal mechanical integrity of the well shall be demonstrated by conducting test(s) approved by the Director. In cases where a well has lost mechanical integrity, written approval by the Director is required before the injection can resume. All test data shall be sent to SIP@rrc.texas.gov and a copy to District Director.
- (f) Prior to plugging the well, the permittee shall demonstrate external mechanical integrity as described in Attachment G and it meets the requirements of **16 TAC §5.203(k)**. Written approval by the Director is required before plugging operations may commence. All test data shall be sent to SIP@rrc.texas.gov and a copy to District Director.
- (g) The Director may require the use of other tests to demonstrate mechanical integrity other than those listed above, provided that the type of test has the written approval of the Administrator pursuant to requirements at **16 TAC §5.203(h)(2)(E)**. All test data shall be sent to SIP@rrc.texas.gov and a copy to District Director.

3. Prior Notice, MIT Procedures and Reporting –

- (a) The permittee shall notify the Director in an electronic format of intent to demonstrate mechanical integrity at least 30 days prior to such a demonstration. At the discretion of the Director a shorter time period may be allowed.

- (b) The mechanical integrity tests and procedures are listed in Attachments D and F. Use of non-approved tests and procedures may result in disqualification of the tests.
- (c) Reports of mechanical integrity demonstrations which include logs shall include an interpretation of results by a knowledgeable log analyst. The permittee shall report in an electronic format the results of a mechanical integrity demonstration within 30 days of the testing.

4. Gauge and Meter Calibration – Prior to testing, the permittee shall calibrate all gauges and meters used in monitoring and testing required by this permit. A copy of the calibration certificate shall be submitted to the Director in an electronic format with the report of the test per **16 TAC §5.206(e)(5)(B)(i)** and the operator and the director must apply methods and standards generally accepted in the industry in accordance with **16 TAC §5.207(a)(1)**.

5. Loss of Mechanical Integrity –

- (a) If the permittee or the Director finds that a well fails to demonstrate mechanical integrity during a test, or fails to maintain mechanical integrity during operation, or that a loss of mechanical integrity as defined by **16 TAC §5.102(36)** is suspected during operation (such as a significant unexpected change in the annulus or injection pressure), the permittee shall:
 - (i) Cease injection in accordance with Section K(9), and Attachments E or H of this permit;
 - (ii) Take all steps that are reasonably necessary to determine whether there may have been a release of the injected carbon dioxide stream or formation fluids into any unauthorized zone. If there is evidence of potential USDW endangerment, the Emergency and Remedial Response Plan shall be implemented (Attachment H of this permit);
 - (iii) Follow the reporting requirements as directed in Section O of this permit;
 - (iv) Restore and demonstrate mechanical integrity to the satisfaction of the Director and receive written approval from the Director prior to resuming injection; and
 - (v) Notify the Director in an electronic format when injection can be expected to resume.
- (b) If an automatic shutdown (i.e., downhole or at the surface) is triggered, the permittee shall immediately investigate and identify as expeditiously as possible the cause of the shutdown. If, upon investigation, the well appears to be lacking mechanical integrity, or if the required monitoring indicates that the well may be lacking mechanical integrity, the permittee shall take the actions listed above in Section L(5)(a)(i) through (v).

- (c) If the well loses mechanical integrity prior to the next scheduled test date, then the well shall either be plugged or repaired and retested within 30 days of losing mechanical integrity. The permittee shall not resume injection until mechanical integrity is demonstrated and the Director gives written approval to resume injection in cases where the well has lost mechanical integrity.

6. Mechanical Integrity for Monitoring Wells – All monitoring wells shall maintain internal and external mechanical integrity for the entirety of their operational life. No significant leaks in the casing can occur and require corrective actions. The determination of whether the monitoring well has mechanical integrity is at the discretion of the Director. Mechanical integrity tests and procedure for the confining zone, injection zone and USDW monitoring wells are outlined in Attachment F of this permit. Testing and demonstration of monitoring wells shall be conducted on the same schedule as the injection well only for internal pressure tests, but temperature logging shall be conducted every five years. Other tests and/or procedures not listed in this plan will be considered by the Director for approval.

7. Mechanical Integrity Testing on Request from Director – The permittee shall demonstrate mechanical integrity at any time upon written notification from the Director.

M. SEISMIC EVENT RESPONSE

1. Seismic Monitoring –

- (a) Prior to commencing injection, the permittee must deploy and maintain a seismic monitoring system to determine the presence or absence, magnitude, and hypocenter location, of any induced seismic activity of magnitude 1.8 M or above. If, after injection start-up and a subsequent period of sustained injection by all planned injection wells at the maximum permitted rates, the permittee can demonstrate that permanent seismic monitoring is not needed for this project, the Commission may allow the local seismic monitoring to be discontinued and defer instead to state (TexNet) and/or national (USGS) arrays for long-term monitoring.
- (b) The system should be designed with surface monitors and/or downhole monitors as required to meet minimum magnitude of completeness (M_c) of 1.8 M or an alternative site-appropriate minimum magnitude approved by the Director in consultation with the State Seismologist, and to appropriately calibrate event magnitudes and hypo central locations. The system shall be calibrated with check-shots, sonic logs, or other local velocity information, preferably in depth.
- (c) The permittee shall analyze seismic and other relevant data to determine whether the risk of triggering an earthquake of magnitude 3.5 M or greater is significantly increased by injection. If, after analysis of seismic and other relevant data, the permittee determines that there is such an increase in risk, the permittee shall notify the Director immediately and submit to the Director a mitigation plan for the Director's review within 15 days of that determination. The permittee shall implement the plan as approved by the Director. The appropriate response to seismic events depends on the Magnitude (M) of the seismic event according to the following protocol:

2. Seismic events not recorded or M less than 2.0 – Continue normal operations.

3. Seismic events with M equal to or greater than 2.0 but less than 3.5 – The permittee shall notify the Director (District Director or Technical Permitting Director) of any such event within 24 hours, providing information on the status of the injection site. If the annulus pressure of the well decreases below the set alarm, injection operations shall cease. In that situation, within 30 days the permittee shall evaluate the internal mechanical integrity of the well by performing tests in accordance with Section L(2)(a) of this permit. If the well fails the mechanical integrity test or the permittee identifies any problems with the injection system that might impact a USDW, the injection well shall remain shut-in and the permittee shall submit a report in electronic format as soon as possible but no later than five (5) days from the time the permittee becomes aware of the circumstances. The report shall contain a description of the circumstances and if the situation has not been corrected, the anticipated time it is expected to continue; and steps taken or planned to reduce, eliminate, and prevent recurrence of the circumstances. Upon completion of the steps to ensure mechanical integrity and the subsequent mechanical integrity demonstration, the permittee shall submit the results and any other required documentation to the Director in an electronic format. If after the testing the well demonstrates mechanical integrity and issues that might impact USDWs are not identified, the permittee shall provide a report of those findings to the Director for review and approval. Injection operations cannot resume until the Director grants approval to recommence injection.

4. Seismic Events with M equal to or greater than 3.5 – For seismic events equal to or greater than 3.5 M, injection operations shall immediately cease. The permittee shall notify the Director of any such event within 24 hours, providing information on the status of the injection well system. If the annulus pressure decreased below the well's set alarm before shutting in the well, then the permittee shall evaluate the internal mechanical integrity of the well by performing tests in accordance with Section L(2)(a) of this permit. The permittee shall also perform an evaluation of the external mechanical integrity of the well in accordance with Section L(2)(b) of this permit. If the well fails either the internal or external mechanical integrity test or the permittee identifies any problems with the system that might impact a USDW, the injection well shall remain shut-in and the permittee shall submit a report in electronic format as soon as possible but no later than 30 days from the time the permittee becomes aware of the circumstances. The report shall contain a description of the failure and if the failure has not been corrected, the anticipated time it is expected to continue, and steps taken or planned to reduce, eliminate, and prevent recurrence of the failure. Upon completion of the steps to ensure mechanical integrity and the subsequent mechanical integrity demonstration, the permittee shall submit the results and any other required documentation to the Director. Injection operations cannot resume until the Director grants approval to recommence injection.

N. TESTING AND MONITORING REQUIREMENTS

1. Testing and Monitoring Plan – The specific measurement and reporting frequencies are listed in Attachment F.

(a) The permittee shall maintain and comply with the approved Testing and Monitoring Plan included as Attachment F of this permit and with the requirements at **16 TAC**

§§5.206(e), and **5.206(o)(2)(I)**, and any modifications required by the Director after the effective date of this permit. The Testing and Monitoring Plan is an enforceable condition of this permit. Samples and measurements taken for the purpose of monitoring shall be representative of the monitored activity. Procedures for all testing and monitoring under this permit shall be submitted to the Director in an electronic format for approval at least 30 days prior to the test if they plan to deviate from the procedures outlined in Attachment F of this permit. When the test report is submitted, a full explanation shall be provided as to why any approved procedures were not followed. If the approved procedures were not followed, the Director may take appropriate action, including but not limited to, requiring the permittee to re-run the test.

- (b) The permittee shall update the Testing and Monitoring Plan as required by **16 TAC §5.207(a)(2)(D)** to incorporate monitoring and operational data and in response to AoR reevaluations required under Section G(1) of this permit or demonstrate to the Director that no update is needed. The amended Testing and Monitoring Plan or demonstration shall be submitted to the Director in an electronic format within one year of an AoR reevaluation; following any significant changes to the facility such as the addition of monitoring wells or newly permitted injection wells within the AoR; or when required by the Director.
- (c) Following each update of the Testing and Monitoring Plan or a demonstration that no update is needed, the permittee shall submit the resultant information in an electronic format to the Director for review and approval of the results. Once approved by the Director, the revised Testing and Monitoring Plan will become an enforceable condition of this permit.

2. Carbon Dioxide Stream Analysis – The permittee shall analyze the carbon dioxide stream prior to injection and with sufficient frequency to yield data representative of its chemical and physical characteristics, as described in the Testing and Monitoring Plan and to meet the requirements of **16 TAC §5.203(j)(2)(A)**.

3. Continuous Monitoring – The permittee shall install and use continuous recording devices to monitor the injection pressure (at surface and at injection interval), injection flow rate, injection mass, pressure on the annulus between the tubing and the long string of casing, annulus fluid level, and temperature (at surface and at injection interval). This monitoring shall be performed as described in the Testing and Monitoring Plan to meet the requirements of **16 TAC §5.203(j)(2)**. The permittee shall maintain for inspection at the facility an appropriately scaled, continuous record of these monitoring results as well as original files of any digitally recorded information pertaining to these operations.

4. Groundwater (USDW) Monitoring Above the Confining Zone – The permittee shall monitor groundwater (USDW) quality and geochemical changes above the confining zone that may be a result of carbon dioxide movement through the confining zone and additional identified geologic units. All monitoring conducted shall be performed for the parameters identified in the approved Testing and Monitoring Plan at the locations and depths, and at frequencies described in the Testing and Monitoring Plan to meet the requirements of **16 TAC §5.203(j)(2)(D)**.

- 5. Soil & Soil Gas Sampling** – The permittee shall monitor near-surface soil and soil gas using an array of permanent subsurface soil gas probes which will be installed at 20 representative locations throughout the surface projection of the AoR and adjacent DAC facility, as specified in Attachment F. A soil gas monitoring program shall be conducted during both pre-injection and during injection using permanent soil gas probes as an ongoing, active sample collection method as described in the Testing and Monitoring Plan to meet the requirements of **16 TAC §5.203(j)(2)(H)**.
- 6. Carbon Dioxide Plume and Pressure Front Tracking** – The permittee shall track the extent of the carbon dioxide plume and pressure front using direct and indirect monitoring methods as described in the approved Testing and Monitoring Plan and in accordance with **16 TAC §5.203(j)(2)(E)**. The permittee is required to conduct this monitoring in order to detect and locate the carbon dioxide pressure front and the dissolved carbon dioxide plume and use the data to calibrate the AoR model to determine whether modifications to the AoR is necessary. The data collected will be used to monitor the location of the plume and pressure front, evaluate its movement through time, and compare to the plume and pressure front predictions of the AoR model. Tracking the extent of the CO₂ plume and the position of the pressure front by using indirect, geophysical techniques, which may include seismic, electrical, gravity, or electromagnetic surveys and/or down-hole CO₂ detection tools.
- 7. Corrosion Monitoring** – The permittee shall perform corrosion monitoring of the well construction materials for loss of mass, thickness, cracking, pitting, and other signs of corrosion on a quarterly basis using the procedures described in the Testing and Monitoring Plan and in accordance with **16 TAC §5.203(j)(2)(C)**. This ensures that the well components meet the minimum standards for material strength and performance set forth in **16 TAC §5.203(e)(1)(B)**.
- 8. External Mechanical Integrity Testing** – The permittee shall demonstrate external mechanical integrity annually as described in the approved Testing and Monitoring Plan and shall comply with Section L of this permit in order to meet the requirements of **16 TAC §§5.203(h)(1)(D)** and **5.206(e)(1)**.
- 9. Pressure Fall-Off Test** – The permittee shall conduct a pressure fall-off test at least once every five (5) years unless more frequent testing is required by the Director based on site-specific information. The test shall be performed as described in the Testing and Monitoring Plan to meet the requirements of **16 TAC §5.203(j)(2)(G)**.
- 10. Additional Monitoring** – If required by the Director as provided in **16 TAC §5.203(j)(2)(H)** the permittee shall perform any additional monitoring determined to be necessary to support, upgrade, and improve computational modeling of the AoR evaluation.). An update shall be made to the Testing and Monitoring Plan, and the subsequent monitoring shall be performed as described in the update.

O. REPORTING AND RECORDKEEPING

The permittee shall submit reports at frequencies described in the approved Testing and Monitoring Plan, and as required by this permit. Reports shall contain all the data and

information required to be monitored, gathered and reported by this permit and meet the requirements of **16 TAC §§5.206(c), 5.206(d), 5.206(e), and 5.207**.

1. Electronic Reporting – All reports, submittals, notifications, correspondence to the Director, and records made and maintained by the permittee under this permit shall be in an electronic format. The permittee shall electronically submit all required reports to an address or location as determined by the Director.

2. Semi-Annual Reports – The permittee shall submit reports on a semi-annual basis in accordance with **16 TAC §5.207(a)(2)(C)**. The reporting period for semi-annual reports will be from January 1 through June 30 and from July 1 through December 31. Reports shall be submitted within 30 days of the end of each reporting period. Semi-annual reports shall include all data collected on a continuous, daily, monthly, quarterly and semi-annual basis as described in the approved Testing and Monitoring Plan. The second semi-annual report for each year shall include all data collected on an annual basis as described in the approved Testing and Monitoring Plan. Reports shall contain the following information and data, as well as all other information and data collected not listed below, but as described in the approved Testing and Monitoring Plan:

- (a) Any changes to the physical, chemical, and other relevant characteristics of the carbon dioxide stream from the proposed operating data.
- (b) Monthly average, maximum, and minimum values for injection pressure, flow rate and daily volume, temperature, and annular pressure.
- (c) A description of any event that exceeds operating parameters for annulus pressure or injection pressure specified in this permit.
- (d) A description of any event which triggers the shut-off systems required in Section (K)(6) of this permit pursuant to **16 TAC §5.206(d)(2)(F)** and the response taken.
- (e) The monthly volume and mass of the carbon dioxide stream injected over the reporting period and the volume and mass injected cumulatively as of the end of the reporting period.
- (f) Monthly annulus fluid volume added or removed; and
- (g) Results of the continuous monitoring required in Section N(3) including:
 - (i) A tabulation of: (1) daily maximum injection pressure, (2) daily minimum annulus pressure, (3) daily minimum value of the difference between simultaneous measurements of annulus and injection pressure, (4) daily volume and mass, (5) daily maximum flow rate, and (6) average annulus tank fluid level; and
 - (ii) Graph(s) of the continuous monitoring as required in Section N(3) of this permit, or of daily average values of these parameters. The injection pressure, injection volume and mass and flow rate, annulus fluid level, annulus pressure, and temperature shall be submitted on one or more

graphs, using contrasting symbols or colors, or in another manner approved by the Director.

- (h) Results of any additional monitoring identified in the Testing and Monitoring Plan and described in Section N of this permit.

3. Twenty-Four (24)-Hour Reporting –

- (a) The permittee shall report to the Director any permit noncompliance which may endanger human health or the environment and any events that require implementation of actions in the Emergency and Remedial Response Plan (Attachment H of this permit). Any information shall be provided orally within 24 hours from the time the permittee becomes aware of the circumstances. Such oral reports should include, but need not be limited to the following information:
 - (i) Any evidence that the injected carbon dioxide stream or associated pressure front may cause endangerment to a USDW, or any monitoring or other information which indicates that any contaminant may cause endangerment to a USDW;
 - (ii) Any noncompliance with a permit condition, or malfunction of the injection system, which may cause fluid migration into or between USDWs;
 - (iii) Any triggering of the shut-off system required in Section (K)(7) of this permit (i.e., downhole or at the surface);
 - (iv) Any failure to maintain mechanical integrity;
 - (v) Pursuant to compliance with the requirement for surface air/soil gas monitoring or other monitoring technologies, if required by the Director in accordance with **16 TAC §5.203(j)(2)(H)** due to any release of carbon dioxide to the atmosphere or biosphere; and
 - (vi) Actions taken to implement appropriate protocols outlined in the Emergency and Remedial Response Plan (Attachment H of this permit).
- (b) A written submission shall be provided to the Director in an electronic format within five (5) days of the time the permittee becomes aware of the circumstances described in Section O(3)(a) of this permit. The submission shall contain a description of the noncompliance or emergency, or remedial response and its cause; the period of noncompliance, emergency, or remedial response, including exact dates and times, and, if the noncompliance has not been corrected, the anticipated time it is expected to continue as well as actions taken to implement appropriate protocols outlined in the Emergency and Remedial Response Plan (Attachment H of this permit); and steps taken or planned to reduce, eliminate and prevent recurrence of the noncompliance or emergency or condition requiring remedial response.

4. Reports on Well Tests and Workovers – Report within 30 days, the results of:

- (a) Periodic tests of mechanical integrity;
- (b) Any well workover, including stimulation;

- (c) Any other test of the injection well conducted by the permittee if required by the Director; and
- (d) Any test of any monitoring well required by this permit

5. Advance Notice Reporting –

- (a) **Well Tests** – The permittee shall give at least 30 days advance written notice to the Director in an electronic format of any planned workover, stimulation, or other well test and submit notice at least 48 hours in advance of any actual activity.
- (b) **Planned Changes** – The permittee shall give written notice to the Director in an electronic format, as soon as possible, of any planned physical alterations or additions to the permitted facility. An analysis of any new injection fluid shall be submitted to the Director for review and written approval at least 30 days prior to injection; this approval may result in a permit modification.
- (c) **Anticipated Noncompliance** – The permittee shall give at least 14 days advance written notice to the Director in an electronic format of any planned changes in the permitted facility or activity which may result in noncompliance with permit requirements.

6. Additional Reports –

- (a) **Compliance Schedules** – Reports of compliance or noncompliance with, or any progress reports on, interim and final requirements contained in any compliance schedule of this permit shall be submitted in an electronic format by the permittee no later than 45 days following each schedule date.
- (b) **Transfer of Permits** – This permit is not transferable to any person except after notice is sent to the Director in an electronic format at least 45 days prior to transfer and the requirements of **16 TAC §5.202(c)** have been met. Pursuant to requirements at **16 TAC §5.202(d)(2)(A)(v)(VIII)**, the Director will require modification or revocation and reissuance of the permit to change the name of the permittee and incorporate such other requirements as may be necessary under the SDWA. All financial responsibility cost estimates, documentation, and instruments as required by **16 TAC §5.203(n)** and by Section H of this permit shall be updated and provided to the Director by any new owner or operator of the well.
- (c) **Other Noncompliance** – The permittee shall report in an electronic format all other instances of noncompliance not otherwise reported with the next monitoring report. The reports shall contain the information listed in Section O(3)(a) of this permit.
- (d) **Other Information** – When the permittee becomes aware of failure to submit any relevant facts in the permit application or that incorrect information was submitted in a permit application or in any report to the Director, the permittee shall submit such facts or corrected information in an electronic format within 10 days of discovery in accordance with **16 TAC §5.203(p)**.

7. Records and Record Retention –

- (a) The permittee shall retain records and all monitoring information, including all calibration and maintenance records and all original chart recordings for continuous monitoring instrumentation and copies of all reports required by this permit (including records from pre-injection, active injection, and post-injection phases) for a period of at least 10 years from collection.
- (b) The permittee shall maintain records of all data required to complete the permit application form for this permit and any supplemental information (e.g., modeling inputs for AoR delineations and reevaluations, plan modifications) submitted under **16 TAC §§5.206(l), 5.206(m), and 5.207(e)** until at least 10 years after site closure.
- (c) The permittee shall retain records concerning the nature and composition of all injected fluids until at least 10 years after site closure.
- (d) The retention periods specified in Section O(7)(a) through (c) of this permit may be extended by the Director at any time. The permittee shall continue to retain records after the retention period specified in Section O(7)(a) through (c) of this permit or any extension thereof expires unless the permittee delivers the records to the Director or obtains written approval from the Director to discard the records.
- (e) Records of monitoring information shall include:
 - (i) The date, exact place, and time of sampling or measurements.
 - (ii) The name(s) of the individual(s) who performed the sampling or measurements.
 - (iii) A precise description of both sampling methodology and the handling of samples.
 - (iv) The date(s) analyses were performed.
 - (v) The name(s) of the individual(s) who performed the analyses.
 - (vi) The analytical techniques or methods used and
 - (vii) The results of such analyses.

P. WELL PLUGGING, POST-INJECTION SITE CARE, AND SITE CLOSURE

The permittee shall maintain and comply with the approved Well Plugging Plan (Attachment G) and the approved Post Injection Site Care and Site Closure Plan (Attachment I) and shall comply with the requirements of **16 TAC §§3.14, 5.203(k), 5.205(b), 5.205(c), 5.205(d), and 5.206(k)(6)(A)**. The Well Plugging Plan and the Post-Injection Site Care and Site Closure Plan are enforceable conditions of this permit.

1. Well Plugging Plan Revisions – If data indicates and the permittee deems it necessary, or if the Director requires the approved plans in Attachments G and I of this permit to be modified, revised plan(s) shall be submitted in an electronic format to the Director for review and written approval. Any amendments to the Well Plugging Plan and/or the Post-Injection Site Care and Site Closure plan shall be approved by the Director and shall be incorporated into the permit and are subject to the permit modification requirements at **16 TAC §5.203(k)(3)(A)**.

2. Required Activities Prior to Plugging – The permittee shall flush the wells with an inert buffer fluid, determine the post-injection bottomhole pressure, and perform final internal and external mechanical integrity tests prior to injection well plugging. The internal and external mechanical integrity tests shall be performed as required by Section L of this permit.

3. Notice of Plugging and Abandonment – The permittee shall notify the Director in writing in an electronic format pursuant to **16 TAC §5.206(k)(6)(A)** least 60 days before plugging, conversion or abandonment of the well. A shorter notice period may be allowed at the discretion of the Director.

4. Plugging and Abandonment Approval and Report –

- (a) The permittee shall receive written approval from the Director before plugging the well and shall plug and abandon the well as required by **16 TAC §§3.14 and 5.203(k)**, as described in the approved Well Plugging Plan (Attachment G of this permit).
- (b) Within 30 days after plugging, the permittee shall submit in an electronic format a plugging report to the Director. The report shall be signed and certified by the permittee in accordance with **16 TAC §5.203(k)(4)**, and by the person who performed the plugging operation (if other than the permittee.) The permittee shall retain the well plugging report in an electronic format for ten (10) years following site closure. The report shall include:
 - (i) A statement that the well was plugged in accordance with the approved Well Plugging Plan (Attachment G of this permit); or
 - (ii) If the actual plugging differed from the approved plan, a statement describing the actual plugging and an updated plan specifying the differences from the plan previously submitted and explaining why the Director should approve such deviation. If the Director determines that a deviation from the plan incorporated in this permit may endanger USDWs, the permittee shall replug the well as required by the Director.

5. Temporary Abandonment – If the permittee ceases injection for more than 24 consecutive months, the well is considered to be in a temporarily abandoned status, and the permittee shall plug and abandon the well in accordance with the approved Well Plugging Plan, **16 TAC §5.203(k)**, or make a demonstration of non-endangerment of this well that is satisfactory to the Director while it is in temporary abandonment status. During any periods of temporary abandonment or disuse, the well shall be tested to ensure that it

maintains mechanical integrity, in compliance with the requirements and frequency specified in Section L(2) of this permit. The permittee shall continue to comply with the conditions of this permit, including all monitoring and reporting requirements in compliance with all requirements of this permit and all applicable regulations.

6. Post-Injection Site Care and Site Closure Plan – The permittee shall maintain and comply with the Post-Injection Site Care and Site Closure Plan in Attachment I of this permit and comply with the requirements of **16 TAC §§5.203(m)**, and **5.206(k)**. The Post-Injection Site Care period is the length of time anticipated to demonstrate that the carbon dioxide injection poses no threat to USDWs and is an enforceable condition of this permit.

- (a) Upon cessation of injection, the permittee shall either submit in electronic format for the Director's approval an amended Post-Injection Site Care and Site Closure Plan or demonstrate through monitoring data and modeling results that no amendment to the plan is needed.
- (b) At any time during the life of the project, the permittee may modify and resubmit in an electronic format the Post-Injection Site Care and Site Closure Plan for the Director's approval in accordance with **16 TAC §5.206(k)(1)(B)**. The permittee may, as part of such modifications to the Plan, request a modification to the post-injection site care timeframe that includes documentation of the information at **16 TAC §5.203(m)(7)**.
- (c) The monitoring as outlined in the approved Post-Injection Site Care and Site Closure Plan shall define the position of the carbon dioxide plume and pressure front, provide a comparison of data collected to the predictions made by the AoR model, and demonstrate that USDWs are not being endangered in accordance with **16 TAC §§5.206(e)(3)** and **5.206(k)(3)(A)**.
- (d) Prior to authorization for site closure, the permittee shall submit to the Director for review and approval, in an electronic format, a demonstration, based on information collected pursuant to Section P(6)(b) of this permit, that the carbon dioxide plume and the associated pressure front do not pose an endangerment to USDWs and that no additional monitoring is needed to ensure that the project does not pose an endangerment to USDWs, as required in **16 TAC §5.206(k)(3)**. The Director reserves the right to amend the post-injection site monitoring requirements (including an extension of the monitoring period) if there is a concern that USDWs are at risk of endangerment.
- (e) The permittee shall notify the Director in an electronic format at least 120 days before site closure. At this time, if any changes to the approved Post-Injection Site Care and Site Closure Plan in Attachment I of this permit are proposed, the permittee shall submit a revised plan.
- (f) After the Director has authorized site closure, the permittee shall plug all monitoring wells as specified in Attachments G and I of this permit in a manner which will not allow movement of injection or formation fluids that endangers a USDW. The permittee shall also restore the surface site to its pre-injection condition.

- (g) The permittee shall submit a site closure report in an electronic format to the Director within 90 days of site closure. The report shall include the information specified at **16 TAC §5.206(k)(6)**.
- (h) The permittee shall record a notation on the deed to the facility property or any other document that is normally examined during a title search that will in perpetuity provide any potential purchaser of the property the information listed at **16 TAC §5.206(l)**.
- (i) The permittee shall retain for 10 years following site closure an electronic copy of the site closure report, records collected during the post-injection site care period, and any other records required under **16 TAC §§5.203(k), 5.206(j) and 5.206(k)(6)**. The permittee shall deliver the records in an electronic format to the Director at the conclusion of the retention period.

Q. EMERGENCY AND REMEDIAL RESPONSE

The Emergency and Remedial Response Plan describes actions the permittee shall take to address movement of the injection or formation fluids that may cause endangerment to a USDW during construction, operation, and post-injection site care periods. The permittee shall maintain and comply with the approved Emergency and Remedial Response Plan (Attachment H of this permit), which is an enforceable condition of this permit, and comply with the requirements of **16 TAC §5.203(l)**.

- 1.** If the data collected indicates evidence that the carbon dioxide plume and or pressure front may cause endangerment to a USDW, the permittee shall:
 - (a) Cease injection in accordance with Sections K(9) and Attachments E or H of this permit.
 - (b) Take all reasonable steps necessary to identify and characterize any release from the underground injection system.
 - (c) Notify the Director within 24 hours.
- 2.** Annual update is required in accordance with **16 TAC §5.207(a)(2)(E)**. Operators must submit an annual statement, signed by an appropriate company official, confirming that the operator has:
 - (a) reviewed the monitoring and operational data that are relevant to a decision on whether to reevaluate the AOR and the monitoring and operational data that are relevant to a decision on whether to update an approved plan required by §5.203 or §5.206 of this title.
 - (b) determined whether any updates were warranted by material change in the monitoring and operational data or in the evaluation of the monitoring and operational data by the operator and

- (c) Operators must submit either the updated plan or a summary of the modifications for each plan for which an update the operator determined to be warranted pursuant to subclause (l) of this clause. The director may require submission of copies of any updated plans and/or additional information regarding whether or not updates of any particular plans are warranted.

At least every five years, or more frequently if the monitoring and operational data warrant, the permittee shall review and update the Emergency and Remedial Response Plan or demonstrate to the Director that no update is needed. The permittee shall also incorporate monitoring and operational data and in response to AoR reevaluations required under Section G(4) of this permit or demonstrate to the Director that no update is needed. The amended Emergency and Remedial Response Plan or demonstration shall be submitted to the Director in an electronic format within thirty (30) days of an AoR reevaluation in accordance with **16 TAC §5.207(a)(3)**, following any significant changes to the facility such as the addition of injection wells, or when required by the Director. If the amendments to the Emergency and Remedial Response Plan cause the cost estimates to change, then a new Financial Responsibility Demonstration shall be submitted for review and approval by the Director in accordance with Section H of this permit.

3. Following each update of the Emergency and Remedial Response Plan or a demonstration that no update is needed, the permittee shall submit the resultant information in an electronic format to the Director for review and confirmation of the results. Once approved by the Director, the revised Emergency and Remedial Response Plan will become an enforceable condition of this permit.

R. COMMENCING INJECTION

The permittee may not commence injection until:

1. Results of the formation testing and logging program as specified in Section J of this permit and in **16 TAC §5.203(f)** are submitted to the Director in an electronic format and subsequently reviewed and approved by the Director;
2. Mechanical integrity of the wells has been demonstrated in accordance with **16 TAC §§5.102(36), 5.203(h)(1)(B)** and **5.203(h)(1)(D)**, and in accordance with Section L(1) through (3) of this permit;
3. The completion of corrective action required by the Area of Review and Corrective Action Plan found in Attachment A of this permit in accordance with **16 TAC §5.203(d)(1)(C)**;
4. All requirements at **16 TAC §5.203** have been met, including but not limited to reviewing and updating of the Area of Review and Corrective Action, Testing and Monitoring, Well Plugging, Post-Injection Site Care and Site Closure, and Emergency and Remedial Response plans to incorporate final site characterization information, final delineation of the AoR, and the results of pre-injection testing, and information has been submitted in an electronic format, reviewed and approved by the Director;

5. Construction is complete and the permittee has submitted to the Director in an electronic format a notice that completed construction is in compliance with **16 TAC §5.203(e)(1)** and Section I of this permit;
6. The Director has inspected or otherwise reviewed the injection well and all submitted information and finds it is in compliance with the conditions of the permit;
7. The Director has approved demonstration of the alarm system and shut-off system under Section K(7) of this permit; and
8. The Director has given written authorization to commence injection.

S. PAYMENT OF FEES TO THE STATE OF TEXAS

In accordance with **16 TAC §5.205**, the permittee shall pay the following fees:

- 1. Application Fee for Amendment** – The applicant must pay to the Commission an application fee of \$25,000 for each application to amend a permit for a geologic storage facility in accordance with **16 TAC §5.205(a)(1)(B)**.
- 2. Injection Fee** – The operator must pay to the Commission an annual fee of \$0.025 per metric ton of CO₂ injected into the geologic storage facility in accordance with **16 TAC §5.205(a)(2)**.
- 3. Post-Injection Care Fee** – The operator must pay to the Commission an annual fee of \$50,000 each year the operator does not inject into the geologic storage facility until the director has authorized storage facility closure in accordance with **16 TAC §5.205(a)(3)**.

ATTACHMENTS

These attachments include, but are not limited to, permit conditions and plans concerning operating procedures, monitoring and reporting, as required by **16 TAC §§5.203, 5.205, 5.206, and 5.207**. The permittee shall comply with these conditions and adhere to these plans as they are approved by the Director by their incorporation into this permit.

- A. AREA OF REVIEW AND CORRECTIVE ACTION PLAN**
- B. WELL CONSTRUCTION PLAN**
- C. STIMULATION PLAN**
- D. PRE-INJECTION/PRE-OPERATIONAL TESTING PLAN**
- E. INJECTION WELL OPERATING CONDITIONS**
- F. TESTING AND MONITORING PLAN**
- G. WELLS PLUGGING PLAN**
- H. EMERGENCY AND REMEDIAL RESPONSE PLAN**
- I. POST-INJECTION SITE CARE AND SITE CLOSURE PLAN**
- J. FINANCIAL ASSURANCE DEMONSTRATION**

A. AREA OF REVIEW AND CORRECTIVE ACTION PLAN

AREA OF REVIEW AND CORRECTIVE ACTION PLAN
40 CFR §146.84(b)

1.0 Facility Information	3
2.0 Computational Modeling Approach	3
2.1 Simulation Model Background	3
2.1.1 Geocellular Model Introduction.....	3
2.1.2 Simulation Model Name and Authors	4
2.1.3 Description of the Simulation Model.....	4
2.2 Site Characteristics.....	5
2.2.1 Site Overview.....	5
2.2.2 Physical Geography	8
2.2.2 Regional Geology	10
2.2.3 Stratigraphy.....	15
2.2.4 Structural Setting	23
2.2.5 Historical Seismic Activity	28
2.2.6 Geopressure.....	32
2.2.7 Fresh Water Aquifers (Surface Geology)	32
2.2.8 Base of the Underground Source of Drinking Water (USDW).....	35
2.3 Geocellular Model Domain.....	37
2.3.1 Model Geologic Structure.....	39
2.3.2 Geocellular Model Zones and Layering	40
2.4 Porosity and Permeability	42
2.4.1 Porosity	44
2.4.2 Permeability	47
2.5 Constitutive Relationships and Other Rock Properties.....	55
2.6 Penwell Field Calibration	56
2.7 Boundary Conditions	63
2.8 Initial Conditions	63
2.9 Operational Information.....	64
2.9.1 State of Stress and Critical Stress Analysis	66
2.9.2 Mohr Coulomb Failure Analysis	70

3.0 Computational Modeling Results	72
3.1 Predictions of System Behavior.....	72
3.2 Model Calibration and Validation	75
3.2.1 Model sensitivities	75
3.2.2 Geochemical Modeling.....	77
4.0 AoR Delineation	88
4.1 Critical Pressure Calculations.....	88
4.2 AoR Delineation	96
4.2.1 Critical Pressure Front	96
4.2.2 CO ₂ Plume Extent.....	96
4.2.3 Final Area of Review.....	98
5.0 Corrective Action.....	99
5.1 Tabulation of Wells Within the AoR.....	99
5.1.1 Depth of the USDW in wells planned for corrective action	100
5.2 Corrective Action Plans and Schedule.....	100
5.2.1 Corrective Action Plan Overview	100
5.2.2 Modeled Extent of AoR.....	101
5.2.3 Timing of Corrective Action.....	107
5.2.4 Corrective Action Procedures	108
5.3 Plan for Site Access	118
6.0 Re-Evaluation Schedule and Criteria.....	118
6.1 AoR Re-Evaluation Cycle.....	118
6.2 Conditions Warranting an AoR Re-Evaluation Prior to Scheduled Re-Evaluation	120
7.0 References.....	122
Websites	128

1.0 Facility Information

Facility name: Brown Pelican CO₂ Sequestration Project
BRP CCS1, CCS2 and CCS3 Wells

Facility contact:



Well location: Penwell, Texas

BRP CCS1	31.76479314	-102.7289311
BRP CCS2	31.76993805	-102.7332448
BRP CCS3	31.76031163	-102.7101566

2.0 Computational Modeling Approach

Pursuant to 40 CFR §146.86, this plan delineates the Area of Review (AoR) and describes the corrective action plans for wells that require corrective action. Delineation of the AoR is one of the key elements of the Class VI Rule to ensure Underground Sources of Drinking Water (USDW) in the region surrounding the geologic sequestration project may not be endangered by the injection activity.

The AoR is the region surrounding the geologic sequestration project where USDWs may be endangered by the injection activity. The AoR is delineated using multiphase CO₂-brine transport computational modeling, constructed from a geocellular model that accounts for the site-specific hydrogeology and the physical and chemical properties of all phases of the injected carbon dioxide stream and displaced fluids. The AoR delineation is based on available site characterization, monitoring, and operational data as set forth in §146.84. The methods and approaches for developing this complex multiphase simulation model and delineating the AoR are provided below.

2.1 Simulation Model Background

2.1.1 Geocellular Model Introduction

The characterization effort and geocellular modeling workflow undertaken for the Brown Pelican CO₂ Sequestration Project (BRP Project or Project) follows the industry-accepted best practices of Kerans and Tinker (1997). The geocellular model was constructed using Schlumberger's Petrel (v2021) geostatistical modeling software, which is a "reliable technology" for reserve estimation, as defined by the US Securities and Exchange Commission (Society of Petroleum Engineers 2018). Application of this software has been reliably demonstrated in numerous peer-reviewed

journals (e.g., Palermo et al. 2010; Rush and Rankey 2017; He et al. 2019) and from Carbon Capture and Sequestration investigations (e.g., Hosseini et al. 2012; Holubnyak et al. 2014).

2.1.2 Simulation Model Name and Authors

The model was created using the GEM (v2022.10) reservoir simulator with the Greenhouse Gas (GHG) module, from Computer Modeling Group Ltd. (CMG).

2.1.3 Description of the Simulation Model

GEM is a commercially available, compositional, finite-difference simulator that is commonly used to model hydrocarbon production, enhanced oil recovery, and other thermodynamic and fluid flow reservoir processes. GEM has also been used to model carbon capture and storage projects. The GEM's Greenhouse Gas (GHG) module accounts for the thermodynamic interactions between three phases: a H₂O-rich phase (liquid), CO₂-rich phase (gas), and a solid phase, which may include several minerals. Physical properties (e.g., density, viscosity, enthalpy) of the H₂O and CO₂ phases and CO₂ solubility in H₂O are calculated from a correlation suitable for a wide range of typical CO₂ storage formation conditions, including temperature ranges between 54°F and 300°F and pressures up to 16,000 psi. Details of this method can be found in Collins et al. (1992), Thomas and Thurnau (1983), and Nghiem and Li (1989).

The phase interactions throughout the simulations are governed as follows:

- The CO₂-rich phase (gas) density is obtained using the Peng-Robinson equation of state. The model was calibrated and modified as described in *Equation 1* (Peng and Robinson 1976).
- The CO₂ dissolution in brine is calculated from Henry's Law Constant Correlation using Harvey's method (Harvey 1996).
- The brine density is specified at a reference pressure of 2,200 psi. The brine viscosity is calculated using the Kestin et al. (1981) correlation.
- The CO₂ gas viscosity is calculated per the methods described by Pedersen et al. (1984).

The Peng-Robinson equation of state, as described above, takes this form:

$$p = \frac{RT}{v - b_{mix}} - \frac{a_{mix}}{v^2 + 2vb_{mix} - b^2} \quad \text{Equation 1}$$

Where, v is the molar volume, p is the pressure, T is the temperature in Kelvin, R is the universal gas constant, and a_{mix} and b_{mix} are the mixture-specific functions of temperature and composition calculated from the critical properties and acentric factors of the components. The CMG WinProp

software used with GEM has a built-in library for the properties of CO₂ and CH₄, based on Reid et al. (1977). No changes were made to the library components.

The transition between liquid and gaseous CO₂ can lead to rapid density changes in the gas phase. The simulator uses a narrow transition interval between the liquid and gaseous density to represent the two-phase CO₂ region.

The compression facility controls the CO₂ delivery temperature to the injection well, keeping it between 70°F and 110°F. Consequently, the temperature of the injectant will be comparable to the reservoir formation temperature at the injection interval. Therefore, the simulations were based on isothermal operating conditions with a linear initial reservoir temperature gradient of 0.0072°F/ft and a surface temperature of 70°F.

With respect to the timestep selection, the software algorithm optimizes the timestep duration based on the specific convergence criteria designed to minimize numerical artifacts. For these simulations, the timestep size ranged from 0.001 days to 30 days. In all cases, the maximum solution change over a timestep is monitored and compared to a specified target. Convergence is achieved once the model reaches the maximum tolerance where small changes of the temperature and pressure calculation results occur on successive iterations. Timesteps are chosen so that the predicted solution change is less than the specified target.

2.2 Site Characteristics

2.2.1 Site Overview

A detailed regional and local geologic evaluation of the area around the BRP Project was conducted using geological, geophysical, and petrophysical data obtained from public literature, licensed data, and site-specific data collected for this project. These data are described in the following sections.

The BRP Project is located approximately 20 miles southwest of Odessa, Texas on the Shoe Bar Ranch. Part of the surface acreage is owned by OLCV, and the remaining acreage is leased by OLCV. OLCV conducted a surface assessment of the site to determine its suitability for CO₂ sequestration. The surface assessment included a review of high-resolution satellite imagery and high-resolution drone imagery to determine the presence or absence of surface water, springs, mines, or quarries. The United States Geological Survey (USGS) maintains a database of historical, current and prospective mines. The following sources were consulted to identify surface and near-surface features:

Plan revision number: 3
Plan revision date: 07/30/2024

- USGS Mineral Resources Data System¹
- High-resolution satellite imagery (licensed from Maxar)
- High-resolution drone imagery acquired in July 2023 for this Project

Based on review of these data, there are no springs, mines, or quarries in the BRP AoR. Two small ephemeral ponds are located outside of the AoR, but within the Shoe Bar Ranch.

Environmental Protection Agency (EPA), Texas Commission on Environmental Quality (TCEQ), and the Texas Railroad Commission (TRRC) databases were consulted to determine if the site contained groundwater contamination, industrial or hazardous waste facilities, petroleum tanks, superfund sites or brownfields.

- TCEQ Groundwater Contamination Viewer²
- TCEQ Industrial and Hazardous Waste Facility Viewer³
- TCEQ Petroleum Storage Tank Viewer⁴
- TCEQ Brownfields Viewer⁵
- TCEQ Superfund Sites Viewer⁶
- EPA Superfund Sites Viewer⁷
- TRRC Data (Including Brownfields) Viewer⁸

Based on a review of these data, there is no groundwater contamination, no industrial or hazardous waste sites, no petroleum storage tanks, no brownfields, and no superfund sites in the BRP AoR. Figure 1 shows surface features of the BRP Project site.

¹ <https://mrdata.usgs.gov/mrds/map-commodity.html>

² <https://www.tceq.texas.gov/gis/groundwater-contamination-viewer>

³ <https://www.tceq.texas.gov/gis/ihw-viewer>

⁴ <https://www.tceq.texas.gov/gis/petroleum-storage-tanks-pst-viewer>

⁵ <https://gis-tceq.opendata.arcgis.com/datasets/brownfields-points/explore?location=31.691297%2C-102.767404%2C9.63>

⁶ <https://www.tceq.texas.gov/remediation/superfund/sites/county/ector.html>

⁷ <https://www.arcgis.com/apps/webappviewer/index.html?id=b3d2408f1fb24a03bb68157c91c446b2&extent=-21022431.7148%2C1332394.4297%2C-7843465.046%2C8787756.4205%2C102100>

⁸ <https://gis.rrc.texas.gov/GISViewer/>

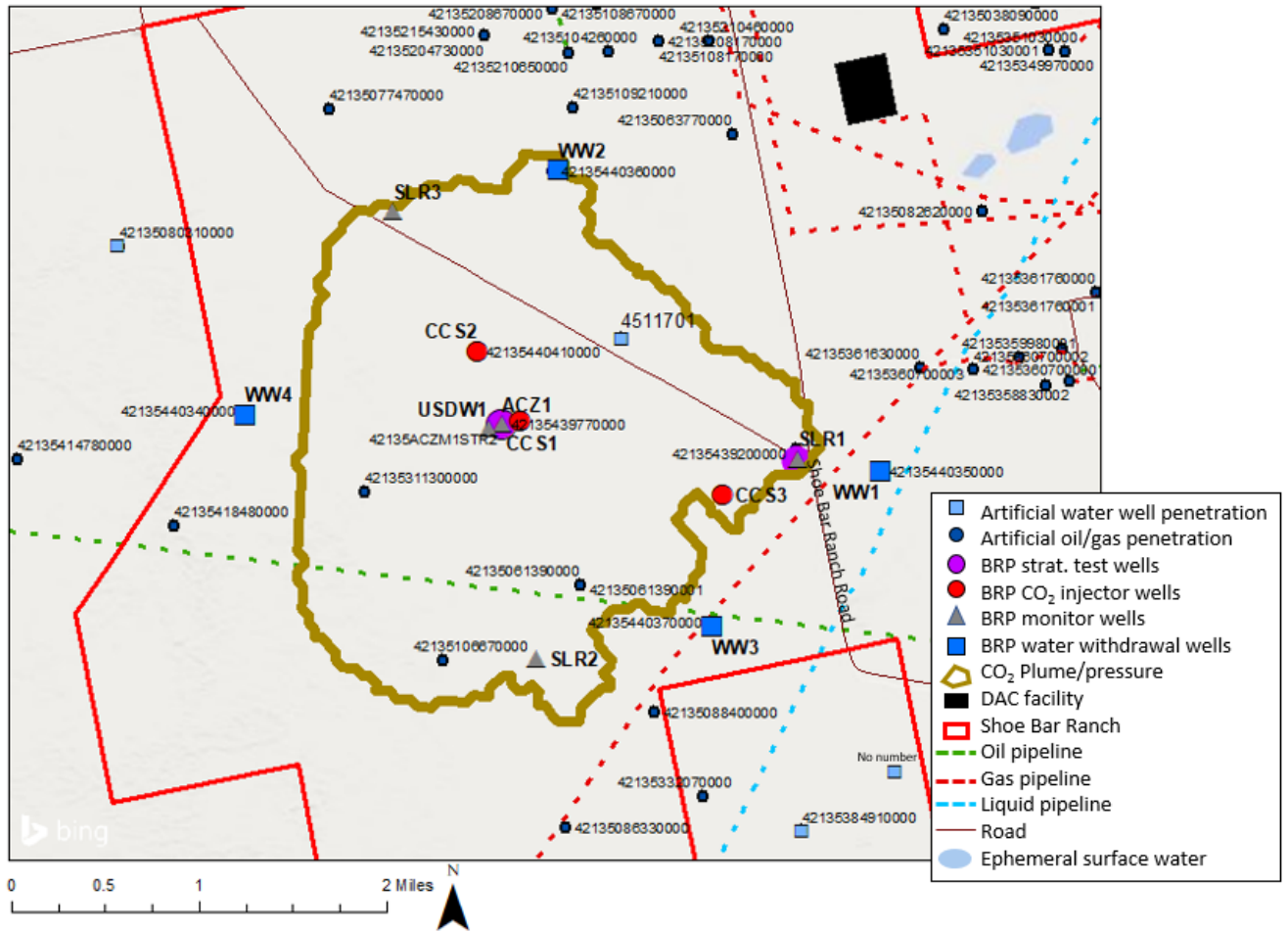

Figure 1—Overview of the BRP Project site AoR

For purposes of this application, the Project site encompasses the areas depicted in Figure 1 and 2 and include: (1) the AoR, (2) the Area of Interest (AoI), which is the area surrounding the AoR in the western half of the Shoe Bar Ranch (SBR) boundary; (3) the Shoe Bar Ranch (SBR), which is the surface land on which the Project is located; and (4) the simulation model outline that encompasses the area of SBR with an approximately one-mile buffer (Figure 2). The Project site includes the total extent of these four areas. The AoR in Figures 1 and 2 represents the combination of maximum extent of CO₂ plume at 50 years post-injection and the pressure plume at the stop of injection in January 2037.

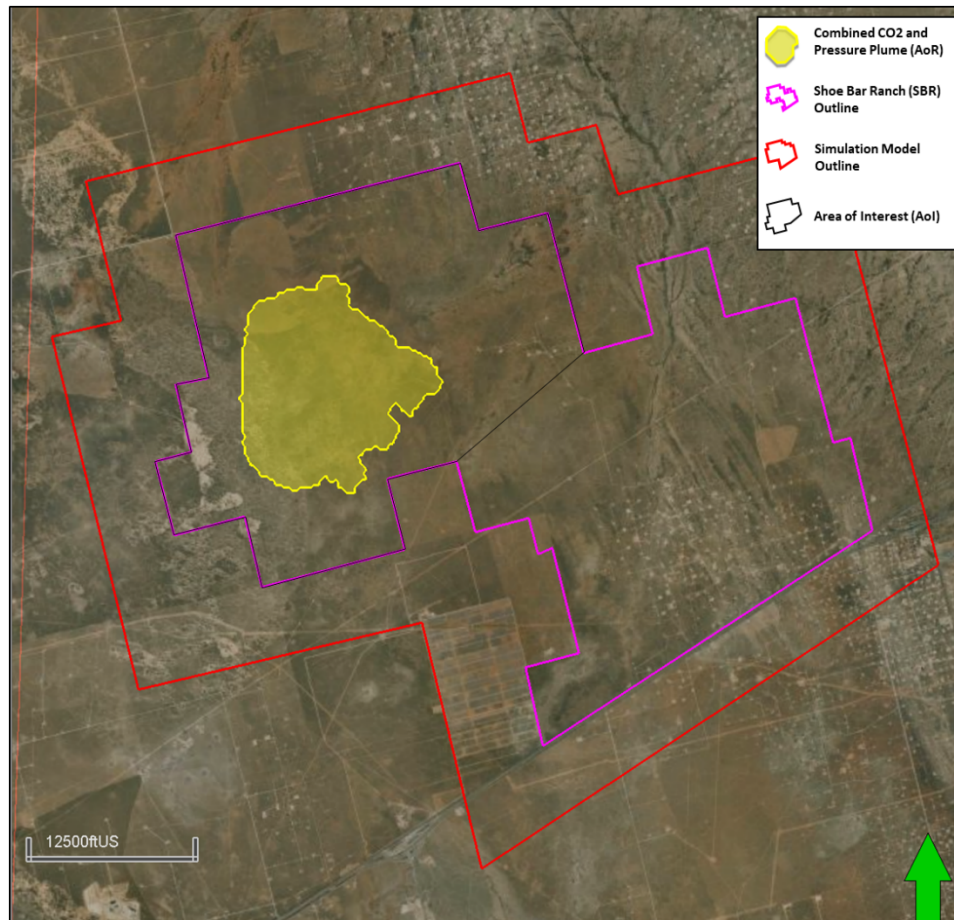

Figure 2—Definition of the outlines used in the Area of Review and Corrective Action Plan document.

2.2.2 Physical Geography

Surface geology in and around Shoe Bar Ranch (Figure 3 and Figure 4) primarily consists of Holocene sand and silt, dunes and dune ridges, caliche, associated alluvium, and other undivided Quaternary deposits (Eifler 1975). The Cretaceous Antlers Sand [Rock Unit Code: Ka] (sandstone, mudstone, and siliciclastic conglomerates) and Triassic Dockum Group [Rock Unit Code: TRd] (shale, sandstone-mudstone, some limestone, and siliciclastic conglomerates) outcrop East of Shoe Bar Ranch (Lehman 1994; Eifler 1975; mrddata.usgs.gov). Surface elevation in and around SBR is

Plan revision number: 3
Plan revision date: 07/30/2024

approximately 3,000 ft above sea level with a dip of 0.25° towards the southwest based on US Geological Survey (USGS) topographic maps (services.arcgisonline.com).

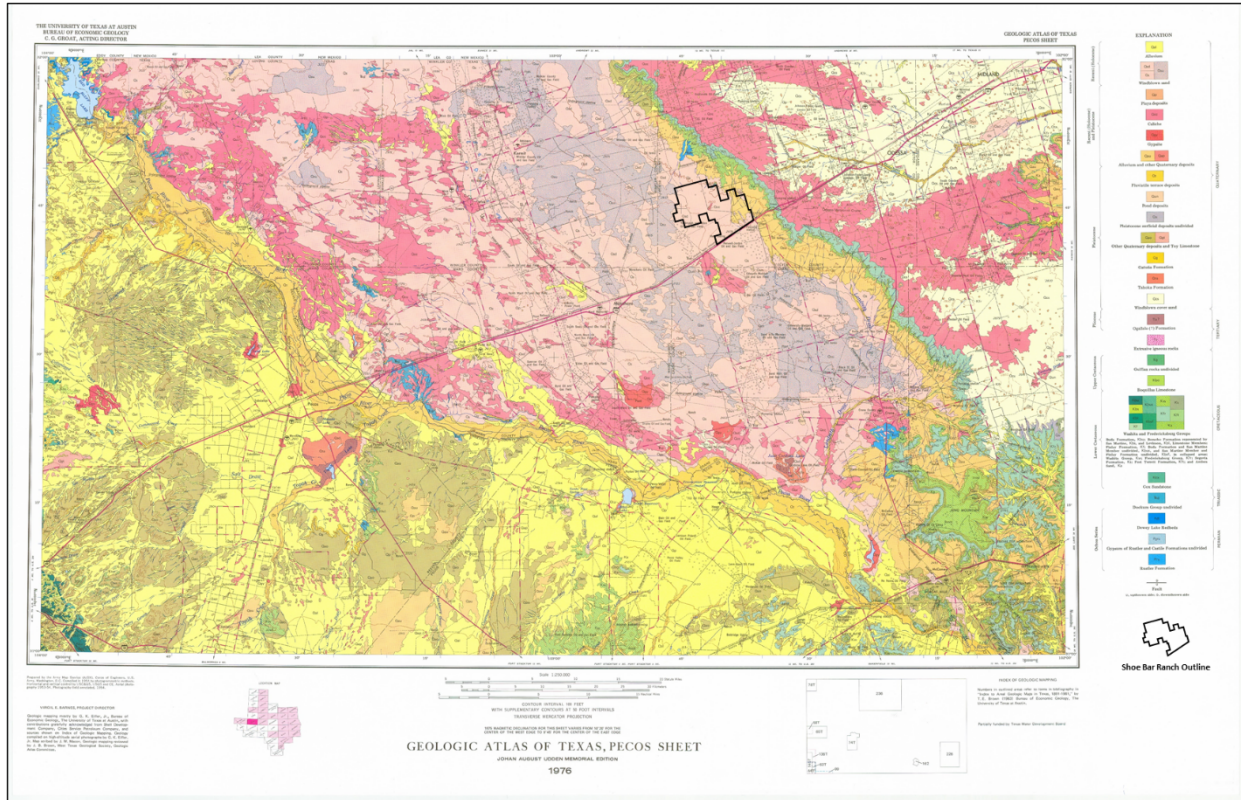

Figure 3—1:250,000 scale surface geology map, Pecos Sheet, Geological Atlas of Texas (Eifler 1975). The Shoe Bar Ranch is outlined in black.

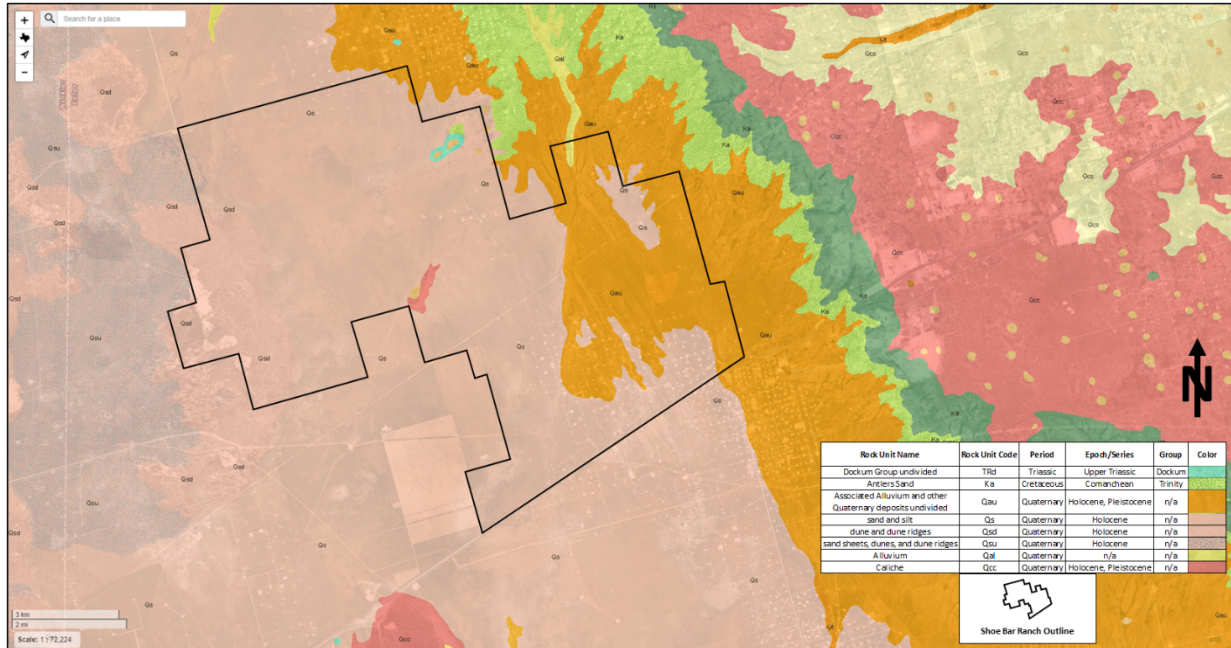

Figure 4—Detailed screenshot of surface geology in the vicinity of Shoe Bar Ranch (from <https://txpub.usgs.gov>).

2.2.2 Regional Geology

The Permian Basin encompasses an area of approximately 250×300 miles and extends across West Texas and southeastern New Mexico (Figure 5). Three major divergent and convergent tectonic events shaped the geometry of the Permian Basin:

1. Neoproterozoic-Cambrian age rifting of Rodinia (Mosher et al. 2004, Ewing et al. 2019);
2. Convergence during the Mississippian-Permian age Ancestral Rocky Mountains and Ouachita-Marathon orogenies (Yang and Dorobek 1995); and
3. The Eocene-Oligocene Laramide orogeny (Henry and Price 1986) (Figure 6).

The Permian Basin was initiated during the Late Mississippian to Early Pennsylvanian as a structurally segmented foreland basin resulting from north-directed convergence of the South American (Gondwanan) plate along the southern margin of the North American (Laurentian) plate (Ross 1986; McBride 1989; Reed and Strickler 1990; Yang and Dorobek 1995). Outcrop-intensive studies of the Ouachita-Marathon orogeny include King’s (1937) classic study of the Marathon fold-and-thrust belt, with more recent studies focusing on syntectonic depositional processes and carbonate platform evolution and provenance of Permian Basin siliciclastic sands (Soto-Kerans et al. 2020; Janson and Hairabian 2016). Convergence and thrust-loading of the North American plate peaked in the Late Pennsylvanian to Early Permian and was followed by isostatic adjustment through fault reactivation and strain-transfer across inherited Proterozoic–Cambrian structures that produced N-S elongated, fault-bound carbonate platforms, and deep marine (1,000+ ft water depth)

siliciclastic-rich basins (Yang and Dorobek 1995; Ewing et al. 2019). Major resulting paleogeographic features include the carbonate-dominated Central Basin Platform, and the siliciclastic-dominated deepwater Delaware Basin and Midland Basin (Figure 5 and 7).

Only minimal tectonic deformation occurred in the Permian Basin since the late Paleozoic, so the present structural features are essentially the same as those inherited from Proterozoic–Early Permian orogenic events (Hills 1984; Ward et al. 1986; Ewing et al. 1993; Yang and Dorobek 1995). The most recent tectonic divergence includes Cenozoic Basin and Range extension and Rio Grande rifting (Henry and Price 1986). These events have generated a complex and regional network of Miocene and younger normal faults that predominantly impact the western margin of the Delaware Basin, where Permian strata have been exhumed along escarpments and westward-dipping horst and grabens that are incised by canyons (King 1948; Boyd 1958).

Regional cross-sections from Yang and Dorobek (1995) demonstrate that Wolfcampian strata are the last interval cut by major basement-rooted faults that bound the Central Basin Platform and further illustrate that upper Pennsylvanian through Wolfcampian strata were deposited across the Permian Basin area during the most significant phase of deformation, as basement-rooted faults are largely absent in Leonardian and younger strata. This observation is consistent with seismic data in the AoI (see Section 2.2.4 Structural Setting).

The Permian Basin of West Texas and New Mexico consists of Wolfcampian to Late Ochoan cyclic and mixed carbonate-siliciclastic-evaporite strata. Platform top depositional environments include the following: salty anhydritic salinas, siliciclastic-rich eolian dunes, carbonate-rich tidal flats, oolitic shorelines and tidal bars, and open-marine shelves (Silver and Todd 1969). The Delaware and Midland basins consist of sand-filled, slope-incised channels and silt-rich slopes that pass basinward into deep-marine (500- to 1,800-ft water depths) turbiditic sandstones and pelagic mudstones (King 1948; Gardner et al. 2003). Formation-scale stratigraphic units provide a complex record of episodic deposition that was driven by the rise and fall of sea levels (100+ ft) (Meissner 1972). This record is characterized by periods of sediment starvation within the basins concurrent with development of basin-fringing carbonate platforms, followed by periods of platform erosion and sediment bypass to the basin floor. During the Late Permian, the Midland Basin became the site of a large evaporitic flat, as recorded by the shallow marine deposits of the Queen Formation. In contrast, the Delaware Basin was infilled by the Late Permian Castile and Salado evaporites that were ultimately deposited across the entire Permian Basin region, including the Northwest Shelf and Central Basin Platform (King 1948).

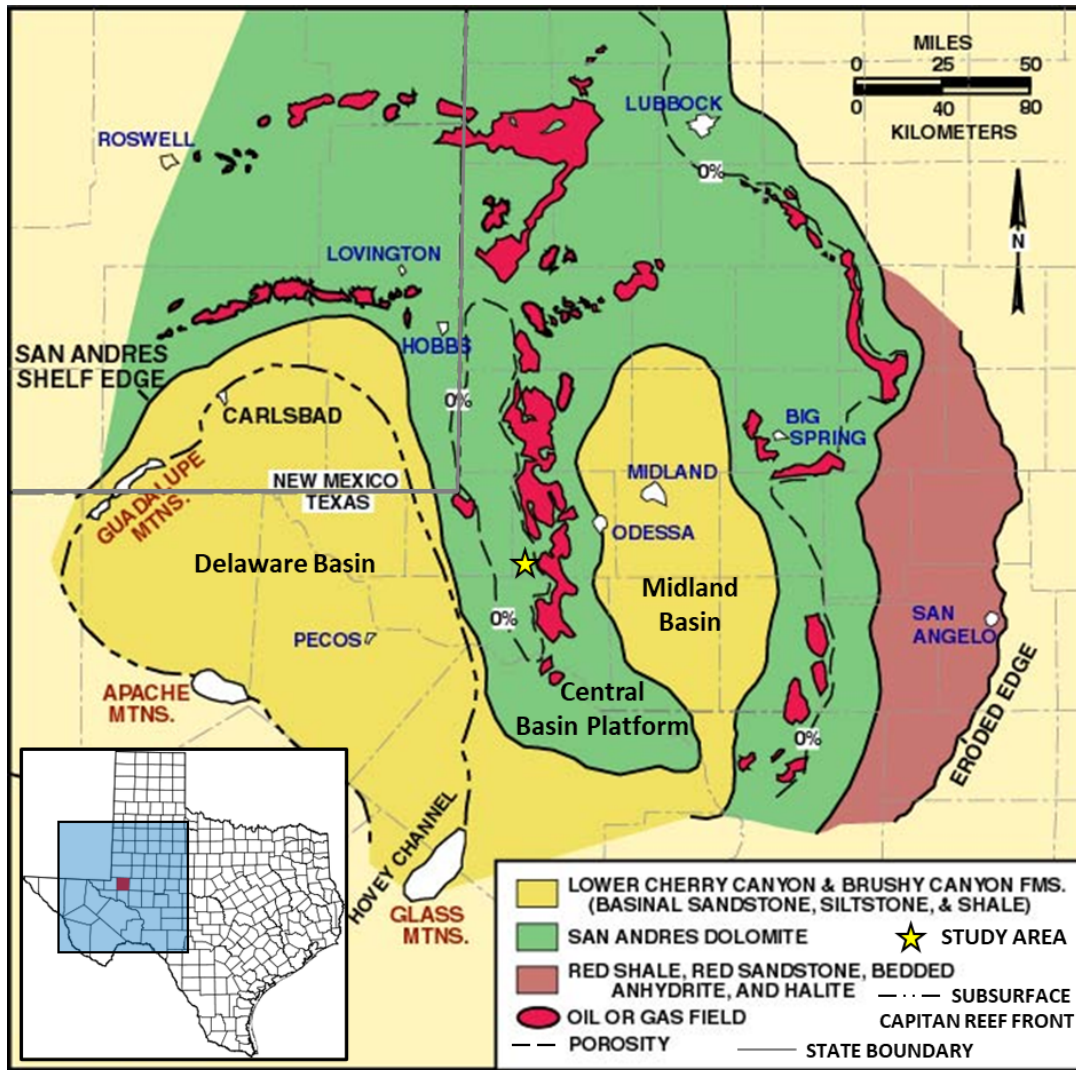

Figure 5—Map of the Permian Basin with the Delaware Basin, Midland Basin, Central Basin Platform, and productive oil and gas fields in the San Andres Formation (after Ward et al. 1986).

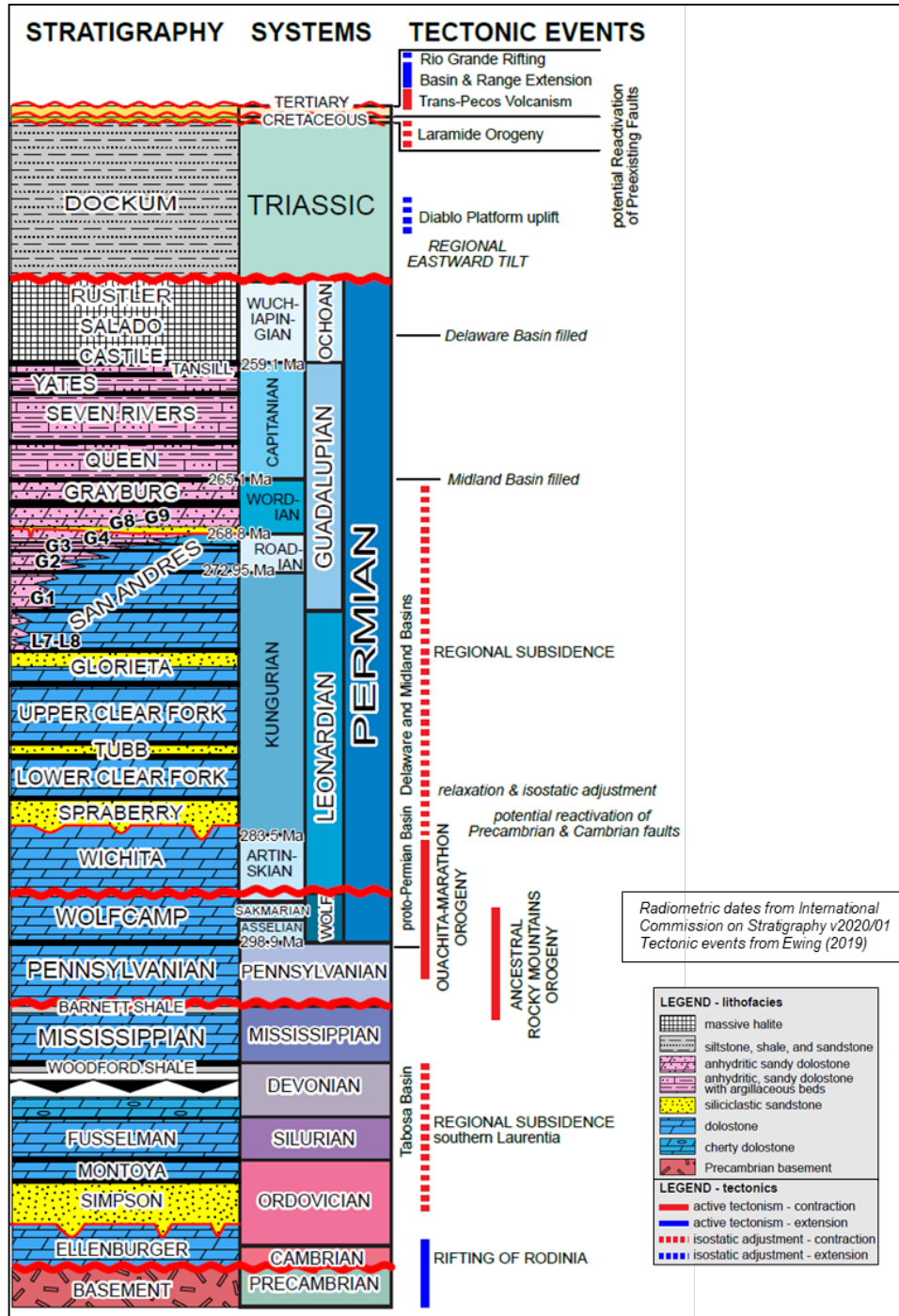

Figure 6—Stratigraphic column for the Central Basin Platform with tectonic events.

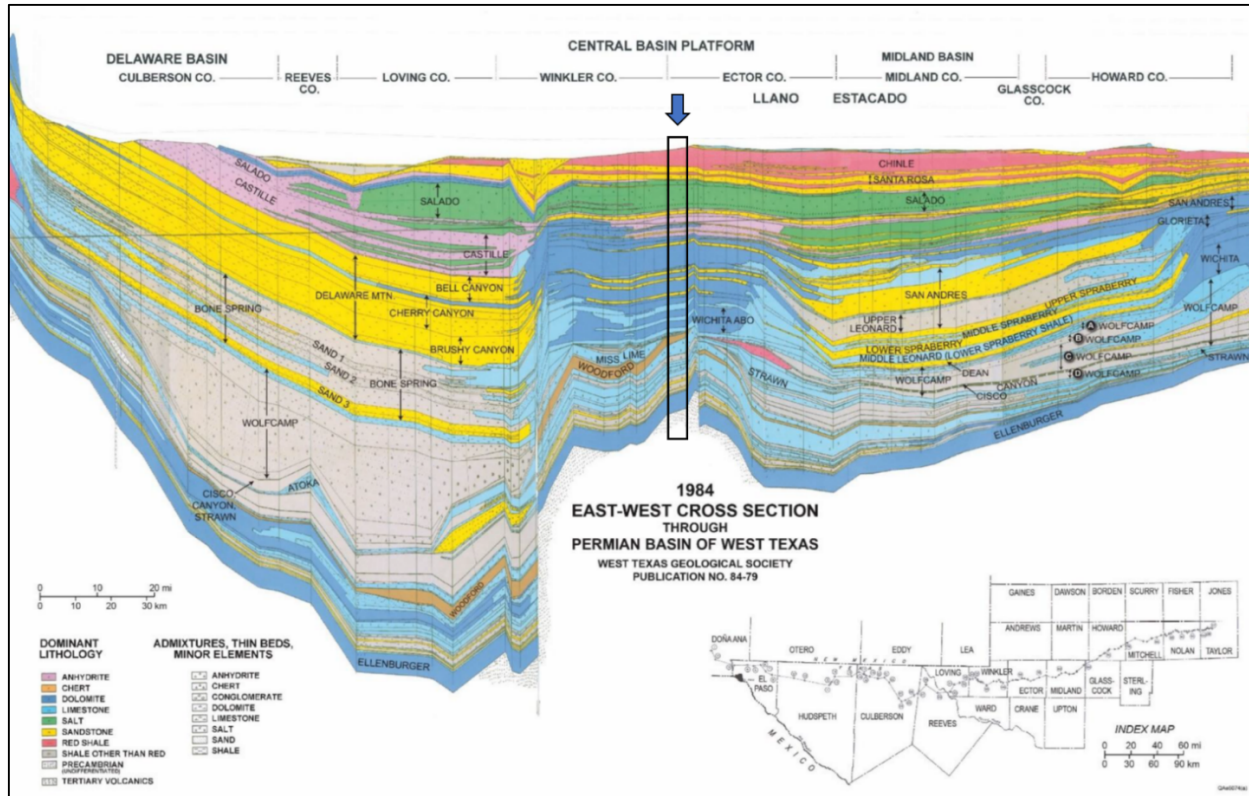

Figure 7—E-W cross section through the Permian Basin of West Texas (from Matchus and Jones 1984). Approximate AoI location on the Central Basin Platform is highlighted with blue arrow and black rectangle.

The San Andres Formation and its basinal equivalents—the Cutoff, uppermost Bone Spring, Brushy Canyon, and Cherry Canyon Formations—provide a complex record of reciprocal sedimentation characterized by periods of basin starvation and carbonate platform aggradation/progradation, followed by periods of platform subaerial exposure and siliciclastic sediment bypass to the basin floors (Figure 7). San Andres sedimentation in the Permian Basin took place in a subtropical setting. Plate reconstructions by Scotese and McKerrow (1990) place the Permian Basin just south of the paleoequator, but paleocurrent studies of approximately time-equivalent eolian strata of the Colorado Plateau (e.g., Coconino Formation) suggest a position 5° north of the paleoequator in the northern equatorial trade-wind belt (Fischer and Sarnthein 1988). This configuration agrees better with earlier work cited by Meissner (1972). Shallow-water carbonate deposits of the San Andres Formation occupied a 60-mile-wide belt separating evaporite-dominated inner-shelf sediments from the deeper-water carbonates of the upper Bone Spring Limestone and the siliciclastic-dominated deposits of the Delaware Mountain Group of the Delaware Basin and equivalent strata in the Midland Basin (Meissner 1972).

2.2.3 Stratigraphy

2.2.3.1 Overview

The CO₂ storage complex in the proposed Project consists of four main elements:

1. Injection Zone (Lower San Andres Formation) with three sub-zones (G4, G1, Holt);
2. Upper Confining Zone (Upper San Andres and Grayburg Formations);
3. Regional Seal / Upper Confining System (Queen through Rustler Formations); and
4. Lower Confining Zone (Upper Glorieta Formation) (Figure 8).

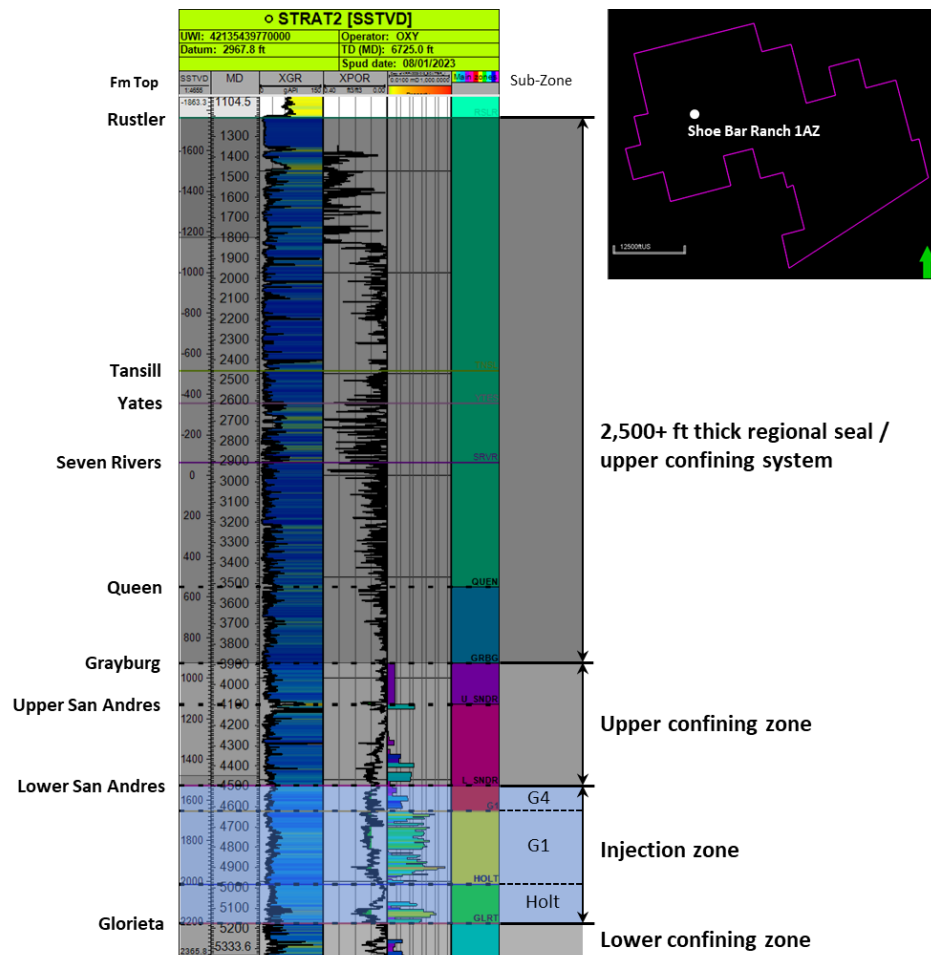

Figure 8—Stratigraphic column covering the Injection Zone, Upper Confining Zone, and Upper Confining System. UWI = Unique Well Identifier; SSTVD = True vertical depth subsea; MD = Measured depth; XGR = Gamma Ray log QCd by Oxy or OLCV petrophysicist; XPOR = porosity log QCd by Oxy or OLCV petrophysicist; K = Permeability

Well log measurements and whole core data from stratigraphic test wells Shoe Bar 1 and Shoe Bar 1AZ (Figure 8 and 9), as well as from the offset Penwell (Upper San Andres) oilfield (gft) were used for the characterization of the storage complex elements. Core analyses from the stratigraphic

wells provided data on porosity, permeability, and capillary entry pressure of the Upper Confining Zone and Upper Confining System in the AoR.

2.2.3.2 Injection Zone

The Lower San Andres Formation exhibits good reservoir quality based on well log and core data in the AoI for each of the three sub-zones: G4 (average porosity = 9.7 %; average permeability = 1.2 mD), G1 (average porosity = 11.2 %; average permeability = 12 mD), Holt (average porosity = 9.4 %; average permeability = 18.8 mD). Data from the Shoe Bar 1 and Shoe Bar 1AZ wells are sufficient to adequately characterize the AoR because the rock and fluid properties from these wells were calibrated to seismic facies and extrapolated beyond the wellbores.

Seismic facies of the G4 and G1 sub-zones are characterized by medium-amplitude, medium continuity, sub-parallel, slightly inclined reflections throughout the 3D seismic coverage (Figures 9, 10A, 10B). Corresponding core facies encountered in Shoe Bar 1 and Shoe Bar 1AZ in sub-zones G4 and G1 are dominated by stacked grain-dominated and mud-dominated dolo-packstones.

Holt sub-zone seismic facies are characterized by high-amplitude, high continuity, sub-parallel, slightly inclined reflections in the western half of the 3D survey and low to medium-amplitude, low to medium-continuity, sub-parallel, slightly inclined reflections in the eastern half of the 3D survey (Figure 9, Figure 10C). Corresponding core facies encountered in the Holt sub-zone of Shoe Bar 1 are dominated by extensively leached and burrowed dolo-wackestones, which create a poor seismic impedance contrast. In contrast, core facies in the Holt sub-zone of Shoe Bar 1AZ comprise a 70' thick tight calcite interval overlying grain-dominated dolo-packstones to dolo-wackestones, creating the strong impedance contrast seen in the seismic data.

Seismic facies observed at the Shoe Bar 1AZ are consistent with the seismic facies observed throughout the majority AoR. Based on calibration of seismic to log data, OLCV interprets that the rock and fluid properties are also anticipated to be consistent throughout the AoR. The seismic facies observed at Shoe Bar 1 are representative of seismic facies observed in the East of the AoR. More details on the seismic survey acquisition and processing are found in section 2.2.5 of this document.

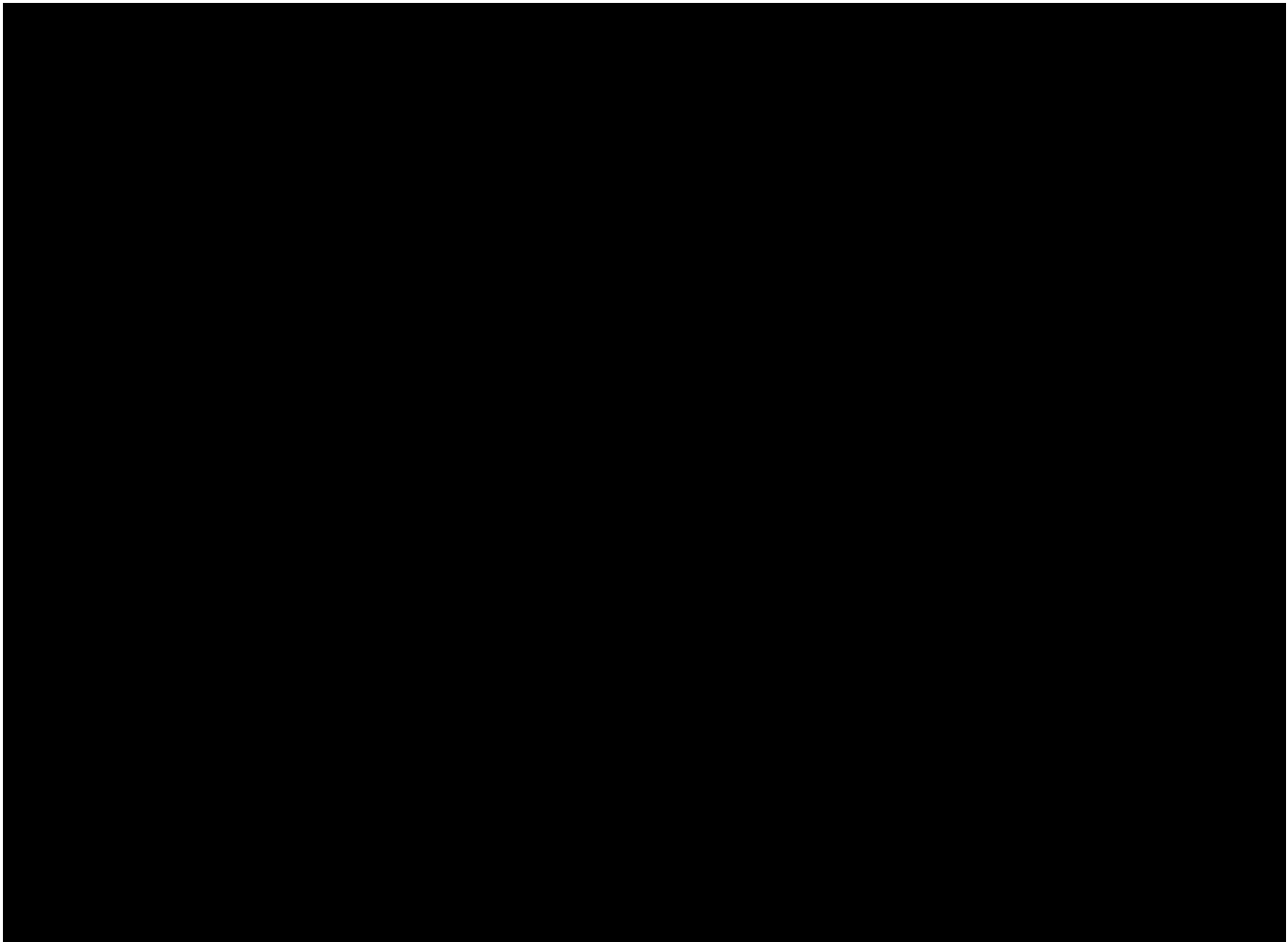

Figure 9—Seismic cross section A-A' with key horizon interpretations and projected well trajectories. Note the change in seismic facies in the Holt sub-zone between Shoe Bar 1 and Shoe Bar 1AZ.



Figure 10—Amplitude extractions demonstrating similarity of seismic facies between Shoe Bar 1AZ and BRP CCS1 and BRP CCS2 in sub-zone G4 (A) and sub-zone G1 (B); amplitude extraction demonstrating change in seismic facies between Shoe Bar 1 and BRP CCS3 (C).

2.2.3.3 Upper Confining Zone

The BRP AoI is positioned in a more landward paleo-depositional environment relative to the producing Penwell oilfield (Figure 11). Therefore, the Upper San Andres Formation (main producing interval in Penwell field) exhibits tighter, more anhydritic supratidal facies and acts as the primary confining layer in the BRP Project. The Upper San Andres Formation was confirmed as a primary confining layer from well log and core data of the Shoe Bar 1 and Shoe Bar 1AZ Stratigraphic wells (average porosity = 6.1 %; average permeability = < 0.1 mD) (Figure 8). The Grayburg formation confining zone properties were also confirmed by porosity logs and MICP-derived porosity / permeability measurements in Shoe Bar 1 (average porosity = 4.1 %; average permeability = < 0.1 mD).

2.2.3.4 Regional Seal / Upper Confining System

The Queen through Rustler Formations form the regional seal / upper confining system and consist of regional, laterally continuous evaporites (anhydrite, halite), shale, and tight silt and form the 2,500-ft Permian regional seal complex for hydrocarbon accumulations in the Permian Basin. These Permian Basin deposits are one of the most extensively studied evaporite systems in the world (Beauheim and Roberts 2002; Anderson et al. 1972; Espinoza and Santamarina 2017; Kendall and Harwood 1989; Dean et al. 2000). These evaporite formations are interbedded with clay and siltstone marker beds that are traceable across much of the western Permian Basin (Anderson et al. 1972). Espinoza and Santamarina (2017) summarized the properties of common lithologies forming confining systems from carbon sequestration projects across the globe, including CO₂ breakthrough pressure for typical top seals (confining layer) such as anhydrite, which form the confining system overlying the Injection Zone. The high capillary entry pressure and low permeability make these lithologies a suitable cap rock for carbon sequestration projects (Espinoza and Santamarina, 2017), in addition to their proven track record of trapping and containing oil and gas in the Permian Basin for 200+ million years (Fairhurst et al., 2021).

2.2.3.5 Lower Confining Zone

Based on petrophysically vetted porosity log measurements in the AoI and NMR-derived permeability estimates from Shoe Bar 1 and Shoe Bar 1AZ stratigraphic wells, the Upper Glorieta Formation exhibits a porosity of <1% and <0.1 mD of permeability and will act as the lower confining layer of the CO₂ storage complex (Figure 8).

2.2.3.6 Environment of Deposition

The proposed storage complex is located approximately 5 miles NW of the Penwell (Upper San Andres) oilfield in a downdip position relative to Penwell (Figure 11). The depositional model for the San Andres Formation in the Penwell oilfield is a low-angle carbonate ramp with shoaling-upward cycles of shallow marine to tidal flat facies (Major et al. 1990; Figure 12). The primary injection and production zone at Penwell is the Upper San Andres (G8-G9).

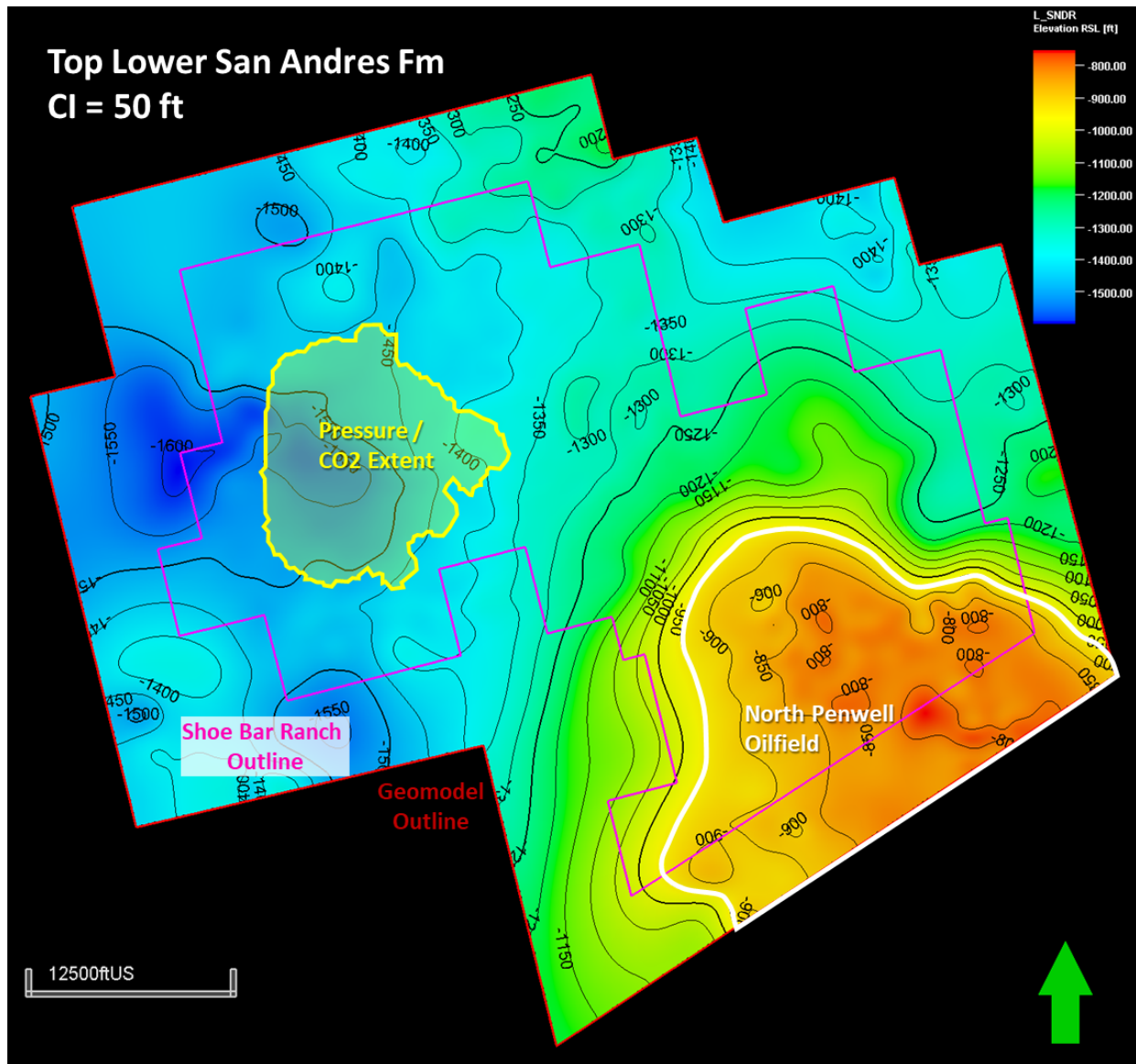

Figure 11—Structure map of the Top Lower San Andres Formation in the Project site (red polygon) with the AoR (yellow polygon) and nearby Penwell (Upper San Andres) oilfield (white polygon).

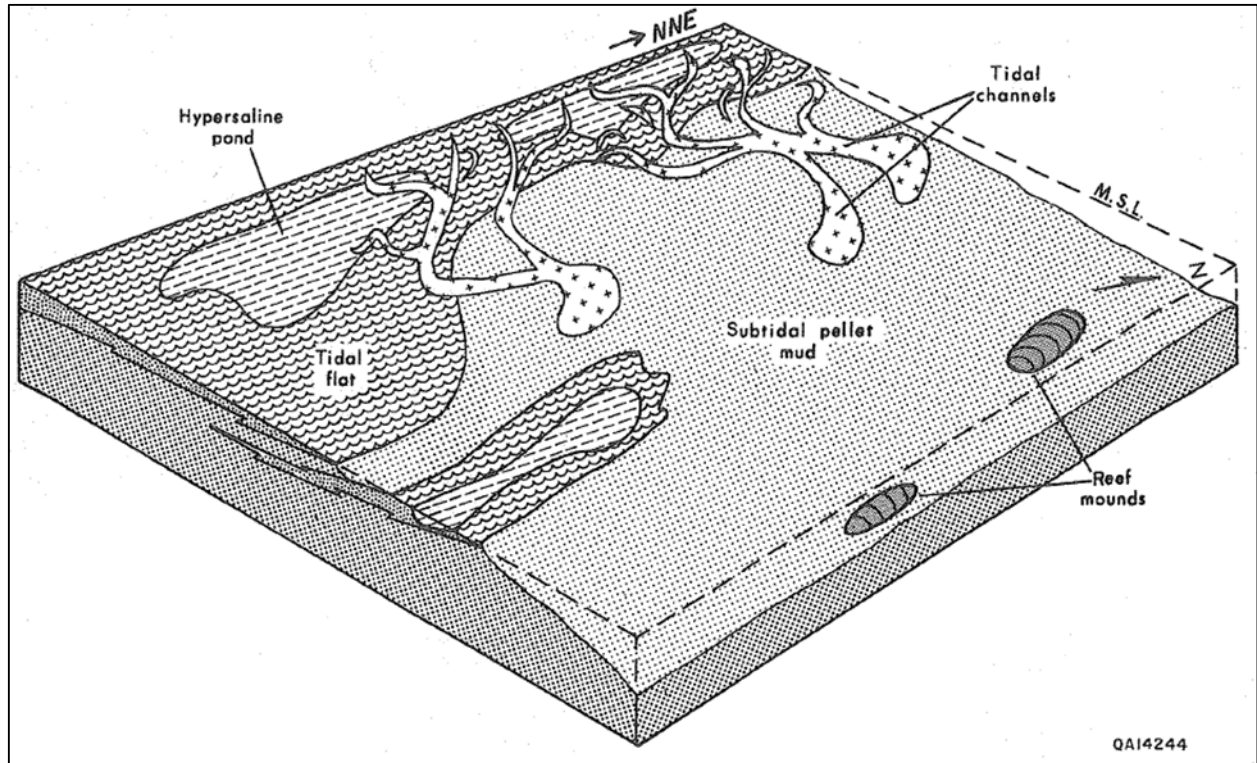

Figure 12—Depositional model of the San Andres Formation at Penwell field (Major et al. 1990).

The BRP Project Injection Zone comprises the Lower San Andres Formation High Frequency Sequences (HFSs) L7–G4. The Upper San Andres Formation (G8–G9 HFSs) (Figure 13) serves as Upper Confining Zone. The Lower San Andres (Permian composite sequence CS10) is divided into a transgressive and highstand sequence set. Key stratigraphic elements and lithofacies characteristics of these sequence sets are summarized below from Kerans and Fitchen (1995), who describe the San Andres Formation as a distally steepened mixed siliciclastic-carbonate ramp.

Key characteristics of the Permian CS10 transgressive sequence set (L7–L8 HFSs):

1. An aggradational platform margin;
2. A backstepped, very low angle ($<2^\circ$) ramp, composed predominantly of skeletal wackestone and minor packstone;
3. Scattered skeletal grain-dominated mounds several hundred to thousands of acres in area that developed on antecedent platform highs within the open shelf; and
4. Grain types dominated by peloids, crinoids, fusulinids, and brachiopods, with less common bryozoans, corals, and calcareous sponges.

Key characteristics of the Permian CS10 highstand sequence set (G1– G4 HFSs):

1. Initially aggradational (G1 HFS) transitioning to progradational (G2-G3 HFSs) and finally, to strongly progradational (G4 HFS);
2. The ramp to outer ramp profile progressively increasing from 0.5° during the G1 HFS to as much as 7° to 12° during the G4 HFS;
3. Development of well-defined platform to basin facies tracts that include:
 - a. Inner ramp evaporites (form the HFS-scale confining layer);
 - b. Middle ramp restricted mudstones and peritidal facies (form the HFS-scale confining layer);
 - c. Ramp crest ooid-peloid grain-rich facies interbedded with mud-dominated subtidal and peritidal facies (form the HFS-scale Injection Zone);
 - d. Shallow outer ramp fusulinid-crinoid-peloid grain-dominated to mud-dominated facies (form the HFS-scale Injection Zone); and
 - e. Distal outer ramp, deepwater, organic-rich mudstone facies (form the base of the HFS-scale Injection Zone).

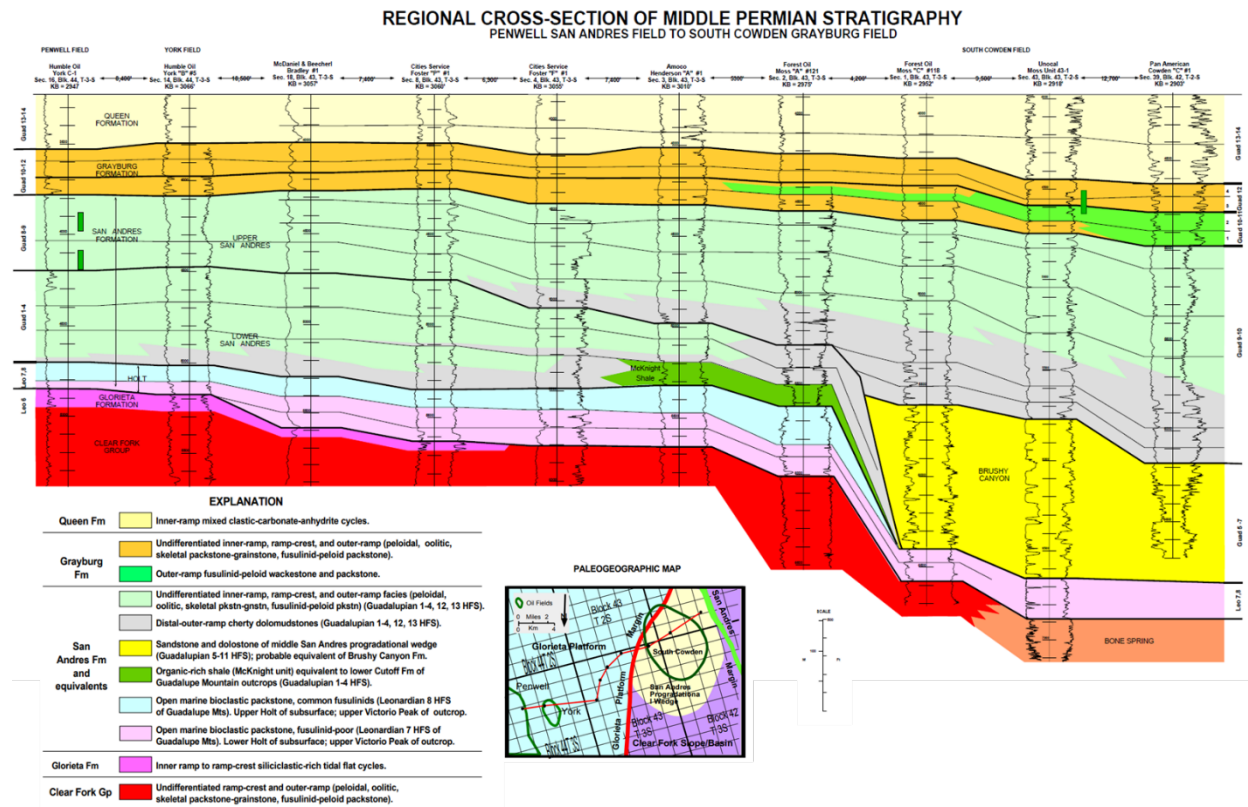

Figure 13—Stratigraphic cross section (from Ruppel and Bebout 1996).

2.2.3.7 Post-deposition Diagenesis

Key control on the lateral heterogeneity of porosity in the San Andres Formation was the early diagenetic preservation of pellets in the fusulinid and mollusk grainstone / packstone facies. Pellet preservation preserved interparticle porosity, whereas pellet compaction destroyed most porosity. The San Andres Formation has been pervasively dolomitized, but still largely retains its depositional texture. The dolomitization process converted syndepositional interparticle porosity to intercrystalline porosity during hypersaline reflux dolomitization (Lucia and Major 1994). This textural inversion process increased permeability in lower quality (i.e., mud-dominated) reservoir rocks and slightly decreased permeability in better quality (i.e., grain-dominated) reservoir rocks. These hypersaline fluids likely precipitated anhydrite and gypsum in the San Andres Formation (Major et al. 1990), resulting in porosity reduction.

2.2.4 Structural Setting

2.2.4.1 Seismic data acquired for the Project

OLCV acquired a high-density, 20.5 mi² 3D seismic survey over the Project site in late 2022. The acquisition parameters for this 3D survey can be found in Table 1. Two orthogonal 2D lines totaling 10 line-miles were acquired in addition to the 3D survey. The 2D lines were acquired using the same source and receiver interval as was used to acquire the 3D survey.

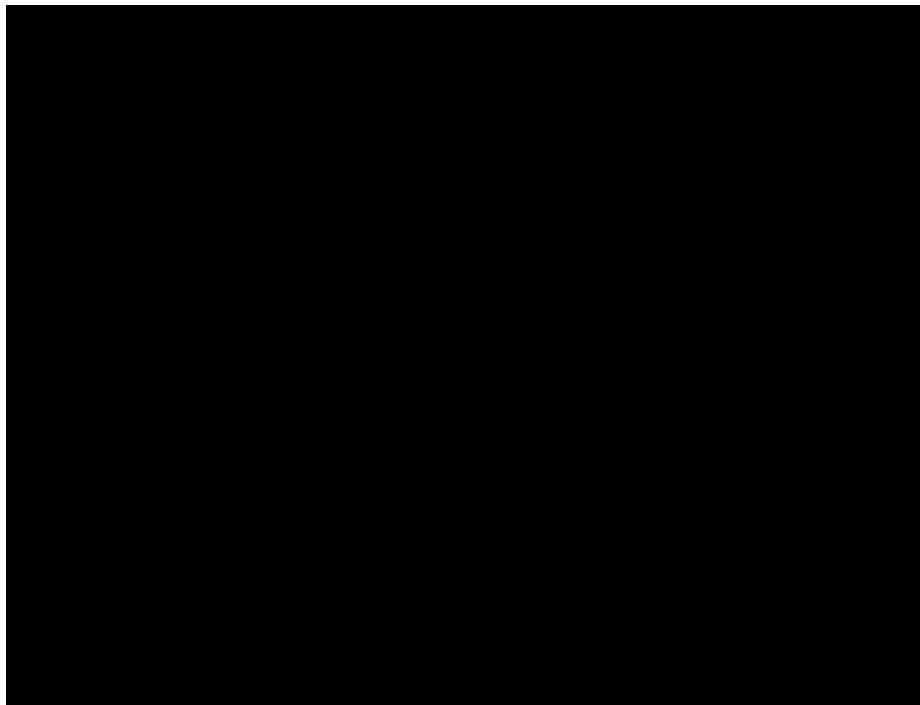

OLCV designed seismic processing workflows to detect and image faults in the BRP Project AoR. Two processing flows were run in parallel for the BRP 3D survey: one flow focused on amplitude preservation for reliable quantitative interpretation, and the other focused on providing the best image for structural interpretation (the latter being used for fault interpretation). Manual fault interpretations were QC'd with fault detection seismic attributes and surface seismic extractions. Fault detection attributes were extracted on full bandwidth data as well as the low, medium, and high frequencies to confirm lack of faulting at all frequency ranges.

2.2.4.2 Interpretation of regional and site-specific seismic data

The Texas Bureau of Economic Geology (BEG) has completed an investigation into faults within the Delaware Basin and Central Basin Platform, including the Shoe Bar Ranch (Figure 14). Horne et al. (2021) compiled the fault interpretations of publicly available 2D and 3D seismic data completed by BEG scientists, in addition to fault interpretations supplied to the BEG by TexNet-CISR⁹ industry participants, covering an area of approximately 23,500 mi² of West Texas.

⁹ <https://www.beg.utexas.edu/texnet-cisr>

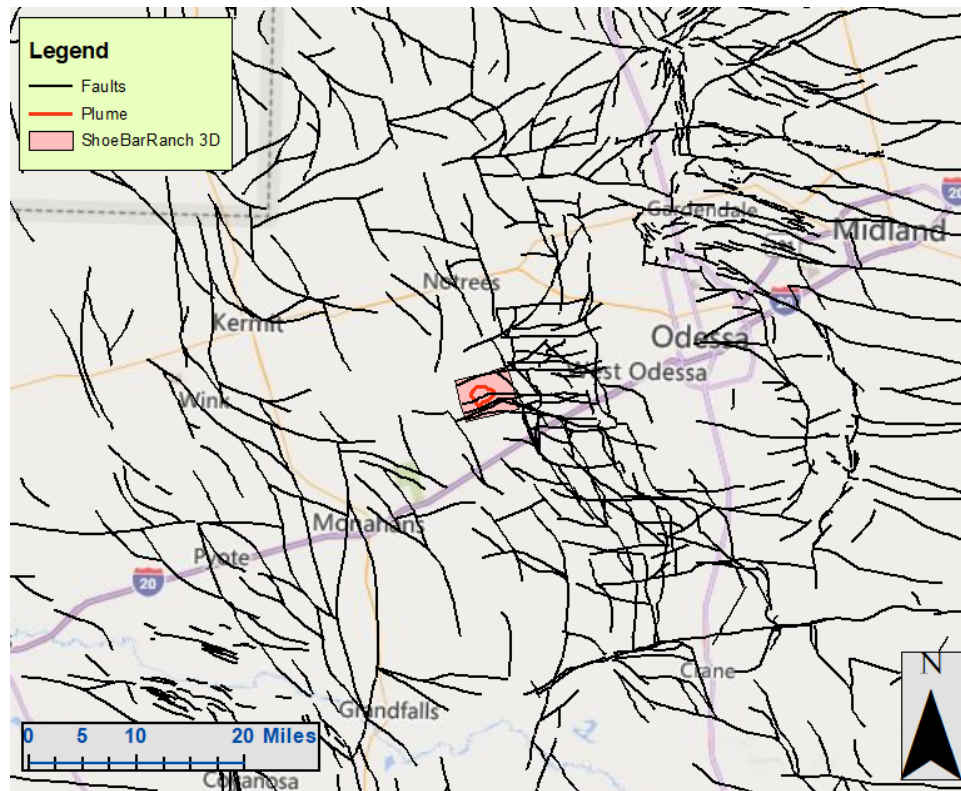

Figure 14—Regional map showing faults published by Horne et al. (2021). Note the deep basement fault interpreted at the South end of the BRP AoR.

Based on the interpretations compiled by the BEG, there is a basement fault striking approximately in an E-W direction that is present within the area of the Project site; however, the fault is interpreted to tip out in strata 1,800 feet below the Lower Confining Zone. Seismic mapping on the newly acquired 3D and 2D, and attribute analyses are consistent with the interpretation that movement on basement-related faults ceased before the time of Wolfcamp deposition. No offset is detectable above the Wolfcamp formation (1,800 feet below base of Lower Confining Zone); therefore, OLCV interprets that deeper faults do not extend to the Lower Confining Zone and Injection Zone (Figure 15 and Figure 16).

In addition to seismic data interpretation, pore pressure data from the Shoe Bar 1 shows that the Glorieta and Clearfork formations are not in pressure communication with the Lower San Andres. The Glorieta and Clearfork are separated from the Lower San Andres Injection Zone by a Lower Confining Zone. The Glorieta and Clearfork have a 0.43 psi/ft and 0.44 psi/ft gradient respectively, whereas the Lower San Andres has a 0.5 psi/ft gradient.

Because no faults are present in either the storage complex or the top or base seals, the risk of induced seismicity due to CO₂ sequestration at the BRP Project is low. There is no evidence to

suggest the deep-seated faults will be reactivated due to the injection of CO₂ within the shallower injection interval by either direct pressure transfer from the reservoir to the basement or poroelastic strain transfer from the reservoir to the basement.

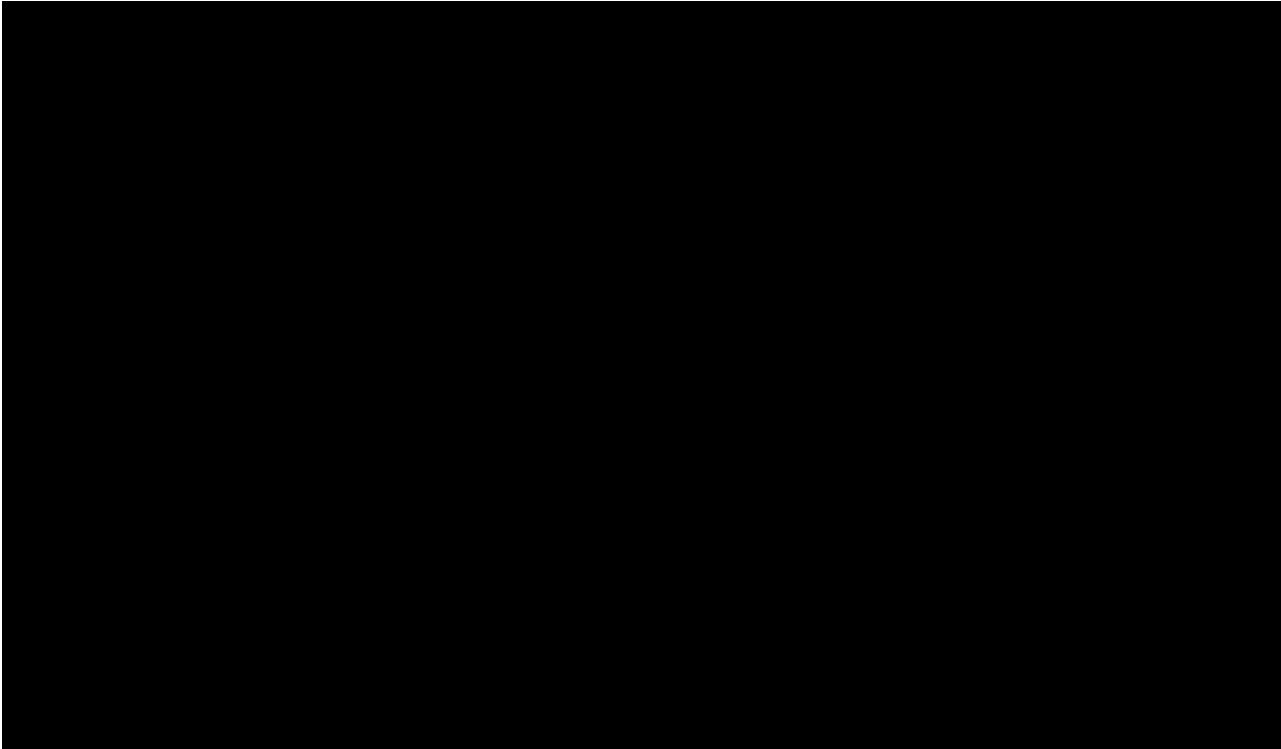

Figure 15—Map view (bottom right corner) of N-S seismic line through the Project.

Seismic cross section shows faults extend from the basement to the Devonian-age strata; however, faulting tips out in the Wolfcamp and does not extend into the Injection Zone. Oxy has licensed a number of 2D seismic lines in the area around the proposed project site. While the Devonian and older strata are faulted, as indicated by the BEG study, the sequestration zone appears to be unfaulted, including the top and upper and lower confining zones (Figure 15). Because the faulting mapped by the BEG and observed on Oxy’s licensed 2D seismic data are not present in either the sequestration zone or the top or base seals, the risk of induced seismicity due to CO₂ sequestration injection into Brown Pelican San Andres reservoir is low.

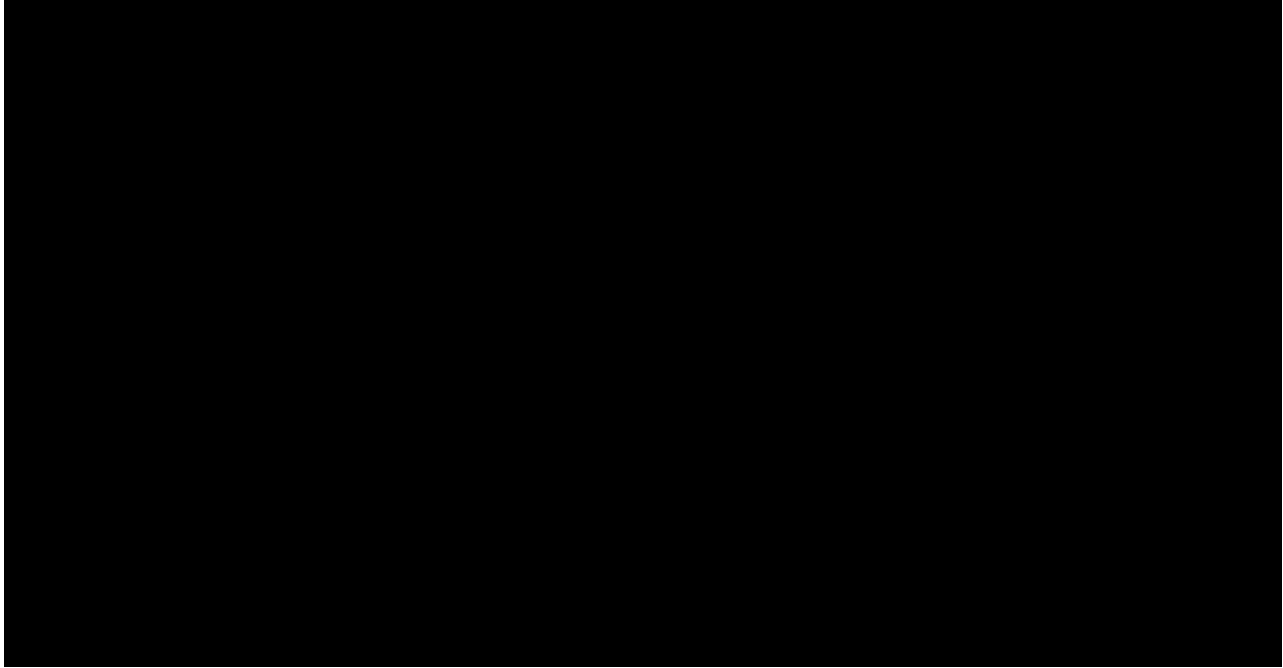

Figure 16—Map view (bottom right corner) of seismic line location across Shoe Bar Ranch. Seismic cross section for that line shows faulting from Devonian to the basement at the site; however, the faulting is truncated at the Wolfcamp and does not extend into the injection zone or lower confining layer.

The geologic structure of the Glorieta Formation (Lower Confining Zone) through the Grayburg Formation (Upper Confining Zone) of the BRP Project (Figure 17) dips gently towards the West at 0.7° (170 ft vertically over 12,500 ft laterally). Due to the low-angle dip, there is minimal difference between true stratigraphical thickness (TST) and true vertical thickness (TVT). The thickness maps in this document are isochore maps, representing true vertical thickness.

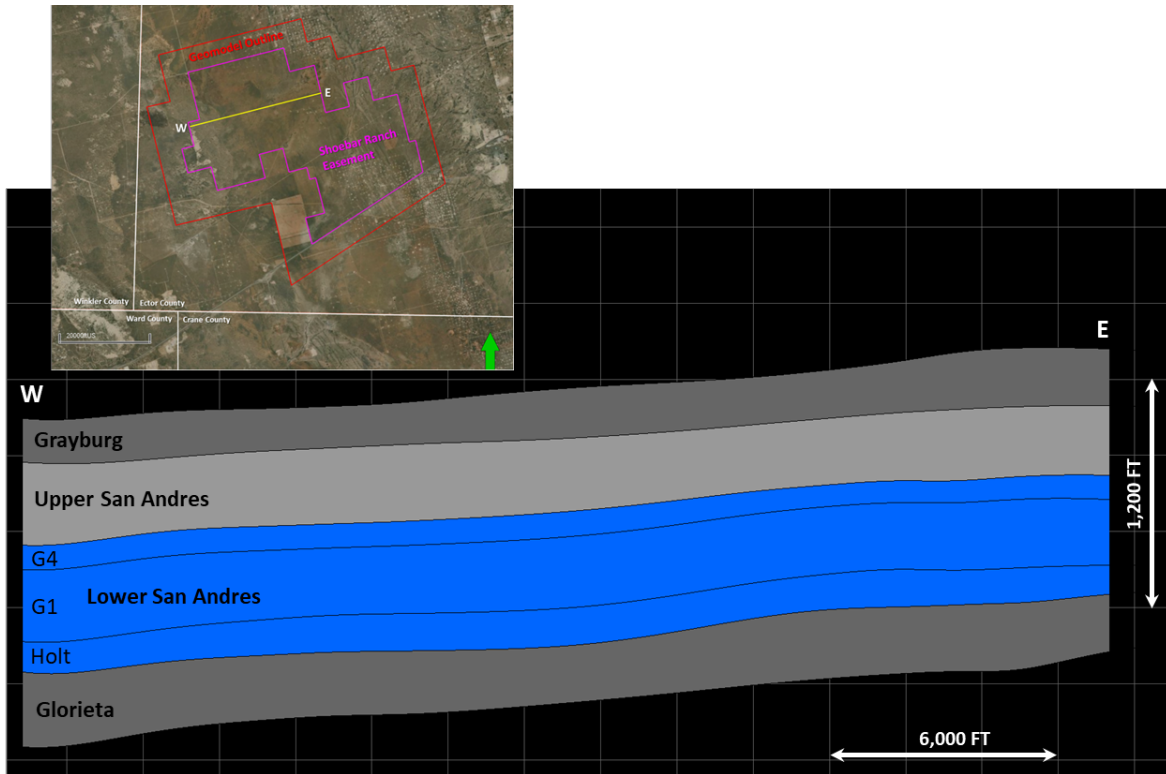

Figure 17—W-E cross section showing the zones modeled for the dynamic simulation, indicating a gentle westward dip.

2.2.5 Historical Seismic Activity

The proposed project site is situated in an area of West Texas that has historically exhibited low historical seismic activity, based on catalogs from both USGS (up to and including December 2016, Figure 18) and TexNet (January 2017 to November 2023, Figure 19). The seismic networks operated by the USGS¹, TexNet, IRIS,¹⁰ and other researchers have varied significantly over the past 50+ years. Appendix C provides the list of the networks, station names, locations, and start and end times for the stations used by USGS and TexNet to locate seismic events.

The recorded event of local magnitude 2 (M_L 2) or greater closest to the project site occurred approximately 5 miles to the east on 22 November 2001. There have been 444 events of magnitude 2 or larger within a 50-mile radius of the Project site reported in the USGS and TexNet catalogs in the past 56 years (as listed in Appendix C: Seismic Events Near Project Site). Recent seismicity

¹⁰ Incorporated Research Institutions for Seismology (<https://www.iris.edu/>)

25 miles North-Northeast of the Project site is attributed to saltwater disposal (SWD) in deeper formations near the basement rock near critically stressed basement faults according to communication on the RRC website in 2022¹¹. The risk to the Project from these recent seismic events is considered minimal, because the proposed Injection Zone is vertically separated from deeper faulted strata by approximately 1,800 ft, as observed on 2D and 3D seismic images, providing sufficient vertical separation to prevent any interaction between injection pressures and the faults. Additionally, OLCV proposes to manage pressure by producing brine from the Injection Zone, further reducing the risk of seismicity from the proposed Project. The USGS predicts this site to have low future seismic hazard (Figure 20). Because of these factors, the site low risk of induced seismicity due to Project operations.

¹¹ <https://www.rrc.texas.gov/oil-and-gas/applications-and-permits/injection-storage-permits/oil-and-gas-waste-disposal/injection-disposal-permit-procedures/seismicity-review/seismicity-response/>

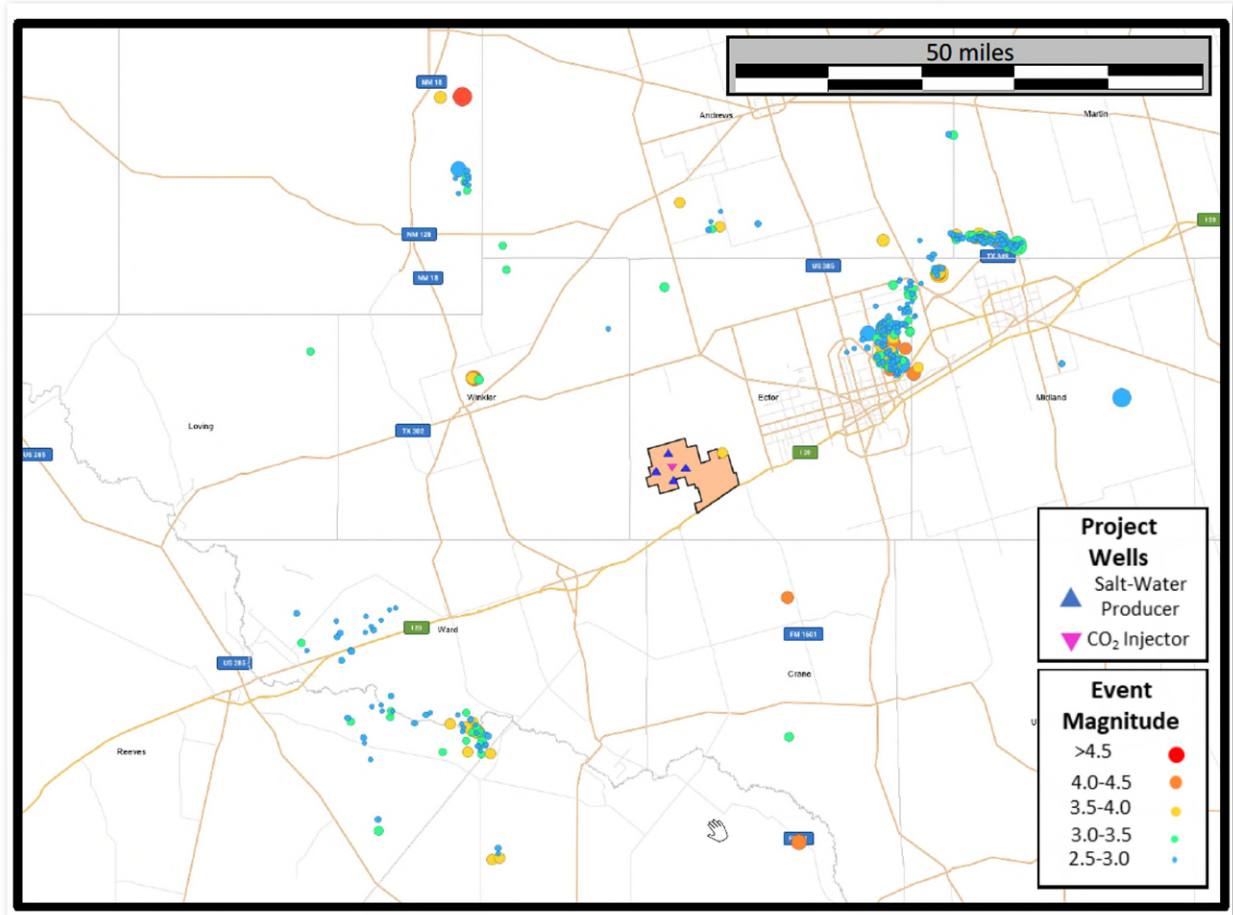

Figure 18—Seismic activity map showing a 50-mile radius around the Shoe Bar Ranch (shaded outline). The closest seismic event observed was 5 miles east of the proposed site in 2001. The seismic cluster 25 miles NE of the proposed Project site is currently attributed to SWD operations in deeper strata close to critically-stressed faults.

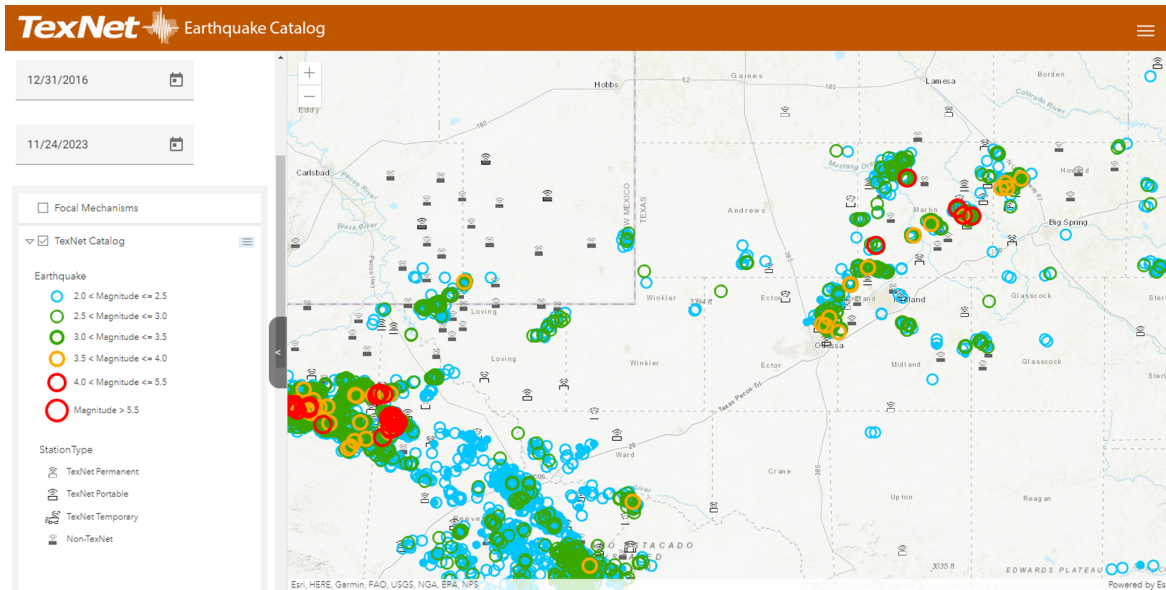

Figure 19—Seismic monitoring network and seismicity greater than 2.0 near Ector County used by TexNet as of 24 November 2023. Seismic monitoring stations are indicated by gray or black boxes (source: <https://www.beg.utexas.edu/texnet-cisr/texnet/earthquake-catalog>,).

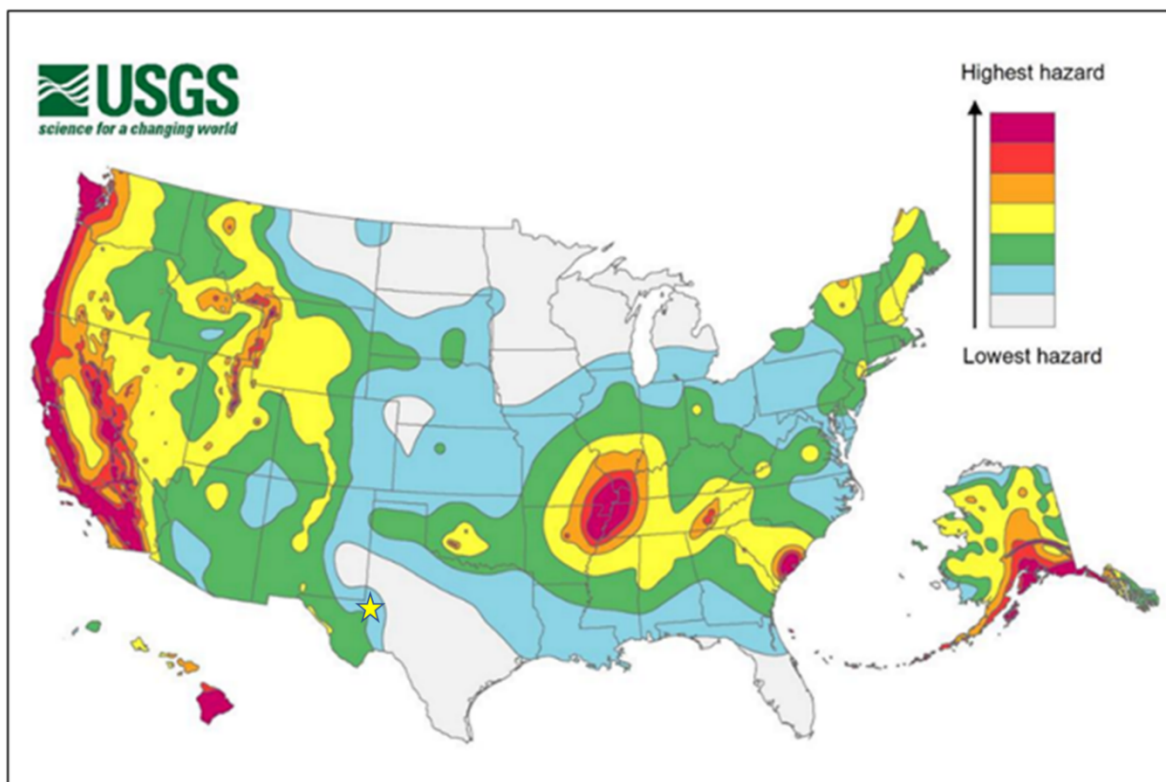

Figure 20—Seismic hazard map showing that peak ground accelerations have a 2% probability of being exceeded in 50 years from USGS 2018 Long-Term National Seismic Hazard Map (USGS 2018). Seismic hazard potential in the AoI is one of the lowest in the US.

2.2.6 Geopressure

The formation pressure information is obtained from well data acquired at Shoe Bar 1 and Shoe Bar 1AZ. The model was initialized at the first date of production using MDT pressure data versus depth. Based on the simulation model initialization, the reservoir pressure in the proposed Injection Zone is slightly overpressured relative to hydrostatic conditions.

2.2.7 Fresh Water Aquifers (Surface Geology)

The formal definition of a USDW by EPA Class VI regulation (40 CFR §144.3) is used in this study:

Underground source of drinking water (USDW) means an “aquifer” or its portion:

- a) 1) *Which supplies any public water system; or*
- 2) *Which contains a sufficient quantity of ground water to supply a public water system;*
and:
 - i) *currently supplies drinking water for human consumption; or*
 - ii) *contains fewer than 10,000 mg/l total dissolved solids; and*
- b) *Which is not an “exempted aquifer.”*

Southeast Ector County has two sources of groundwater in the extent of Shoe Bar Ranch that meet the formal definition of a USDW by EPA Class VI standard (40 CFR §144.3): the Pecos Valley major aquifer (surface; Figure 21), and the Dockum minor aquifer (base USDW; Figure 22) (Bradley and Kalaswad, 2001; Mace et al., 2006; George et al., 2011). Additional data on USDW depths specifically in and around SBR were acquired from Texas Water Development Board (TWDB) Groundwater Advisory Unit (GAU) letters¹².

¹² <https://www.twdb.texas.gov/>

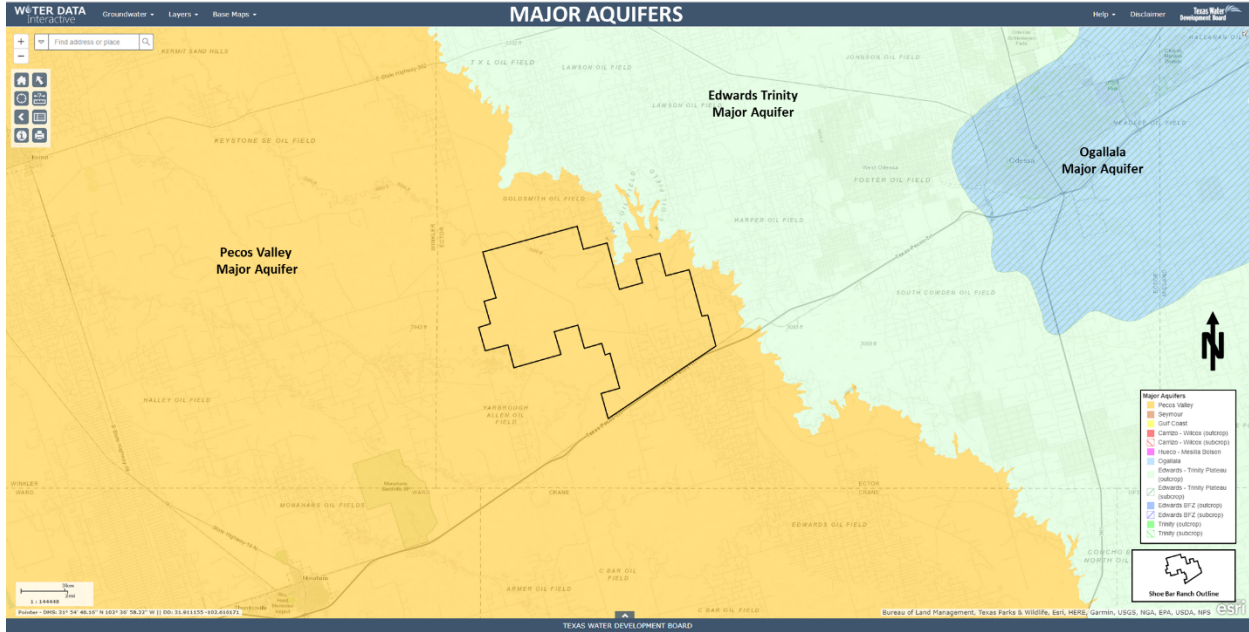

Figure 21—Major aquifers in the AoI and adjacent areas. Shoe Bar Ranch (black outline) is located in the eastern extent of the Pecos Valley aquifer (twdb.texas.gov).

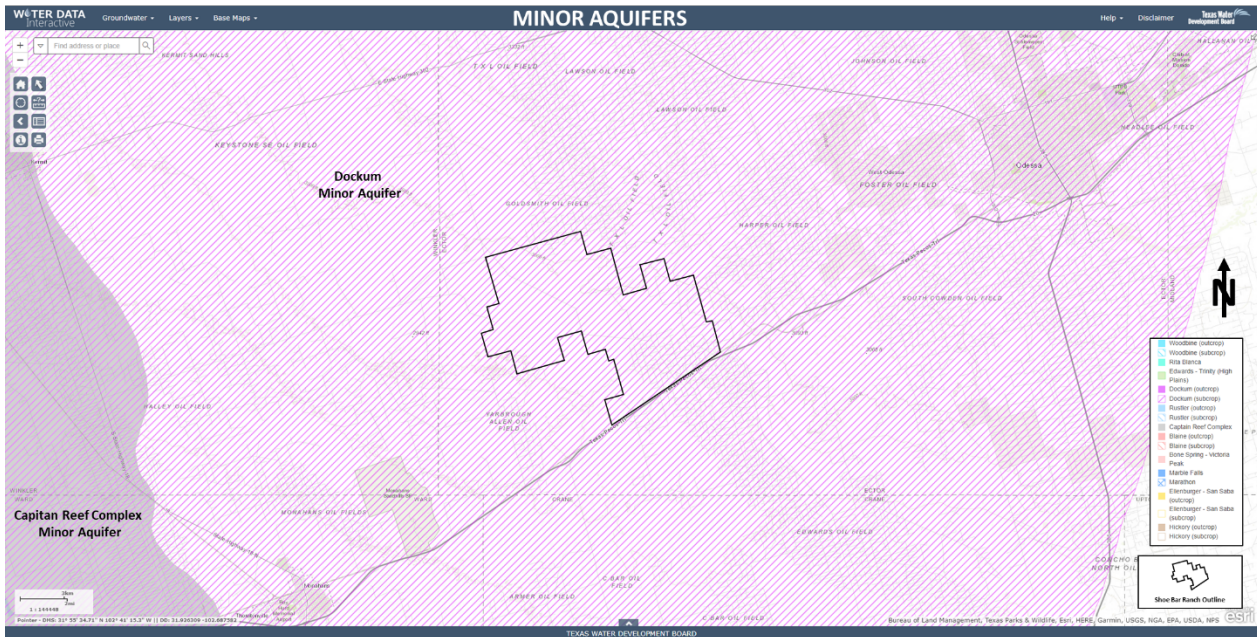

Figure 22—Minor aquifers in the AoI and adjacent areas. Shoe Bar Ranch (black outline) is located within the Dockum minor aquifer region. The closest adjacent minor aquifer is the Capitan Reef Complex aquifer, located 13 miles to the West (twdb.texas.gov).

The Cenozoic Pecos Valley Alluvium forms the Pecos Valley major aquifer and consists of unconsolidated to partially consolidated sand, silt, gravel, clay, and caliche (White 1971). Hydraulic conductivity of the Pecos Valley aquifer in southwest Ector County is ~10 ft/day (Anaya and Jones 2009). The Pecos Valley aquifer is unconfined (Meyer et al. 2012) and extends from ground level to a depth of ~250 ft in the AoI.

Based on regional water quality analyses, TDS concentrations in Ector County are <3,000 ppm in the Pecos Valley major aquifer (Meyer et al. 2012) and <5,000 ppm in the Dockum minor aquifer (Ewing et al. 2008). Therefore, both aquifers meet the definition of a USDW by EPA Class VI regulation (40 CFR §144.3). There are five water withdrawal wells (Figure 23) located within the Shoe Bar Ranch outline: 45-11-701, 45-11-902, 45-11-903, 45-19-301, and 45-19-302.¹³ Only water well 45-11-701 is located in the extent of the AoR (Figure 23). The only available water quality analysis for water withdrawal well 45-11-701 is from 1948, which documents TDS concentrations of the Dockum Formation of ~7,200 ppm. Water analysis reports for wells 45-11-701, 45-11-902, 45-11-903, 45-19-301, and 45-19-302 are attached as a separate file package in the GSDT.

¹³ These water analysis reports will be submitted to the EPA Geological Sequestration Data Tool (GSDT) in a separate folder.

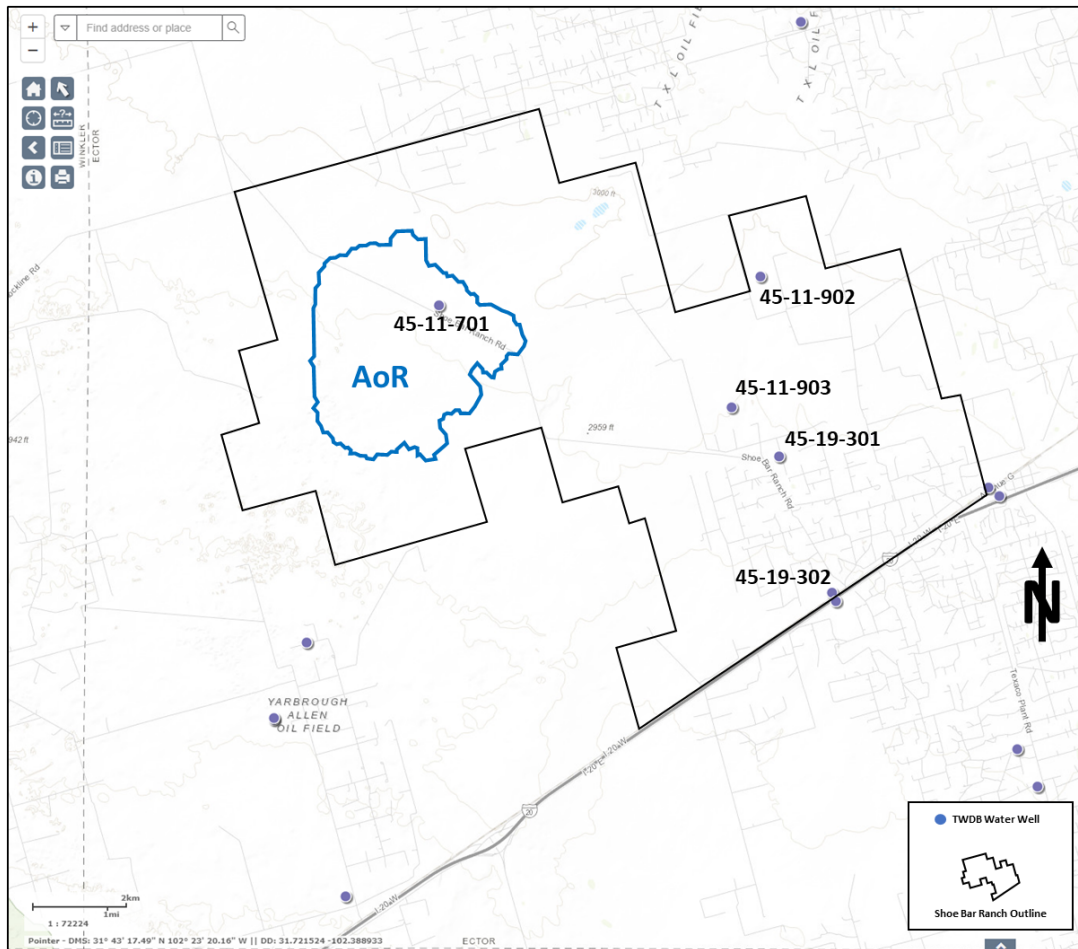

Figure 23—Texas Water Development Board (TWDB) water wells in and around the AoR and Shoe Bar Ranch (from twdb.texas.gov).

2.2.8 Base of the Underground Source of Drinking Water (USDW)

The BRP team employed two means of identifying the USDW in the Shoe Bar Ranch outline: 1) TWDB GAU letters specify the Dockum minor aquifer of the Santa Rosa Formation (depth range: 600 ft to 1,150 ft below ground level) as the base of protected aquifers in the AoI, which is consistent with EPA Class VI regulation (40 CFR §144.3) as deepest layer that has waters with a TDS concentration of less than 10,000 mg/L. 2) Additional means of aquifer identification came from interpreted gamma ray well log responses of TWDB Brackish Resources Aquifer Characterization System (BRACS) Well 1258 (API 4249532726; Figure 24) (Meyer et al. 2012). Data from both TWDB GAU letters and BRACS Well 1258 were used for well log correlation and structural mapping of the base Dockum minor aquifer in the subsurface across the AoI (Figure 24). Stratigraphic cross sections in N-S and W-E orientation with correlated Pecos Valley and Dockum Aquifers, as well as the five water withdrawal wells (45-11-701, 45-11-902, 45-11-903, 45-19-301, and 45-19-302) within the Shoe Bar Ranch outline are provided as separate attachments in

the GSDT (W_E Well Log Section_cbi and N_S Well Log Section_cbi). Structural maps for the Pecos Valley and Dockum Aquifers are provided as separate attachments in the GSDT (Base Pecos Valley Aquifer_cbi; Top Dockum Aquifer_cbi; Base Dockum Aquifer_cbi).

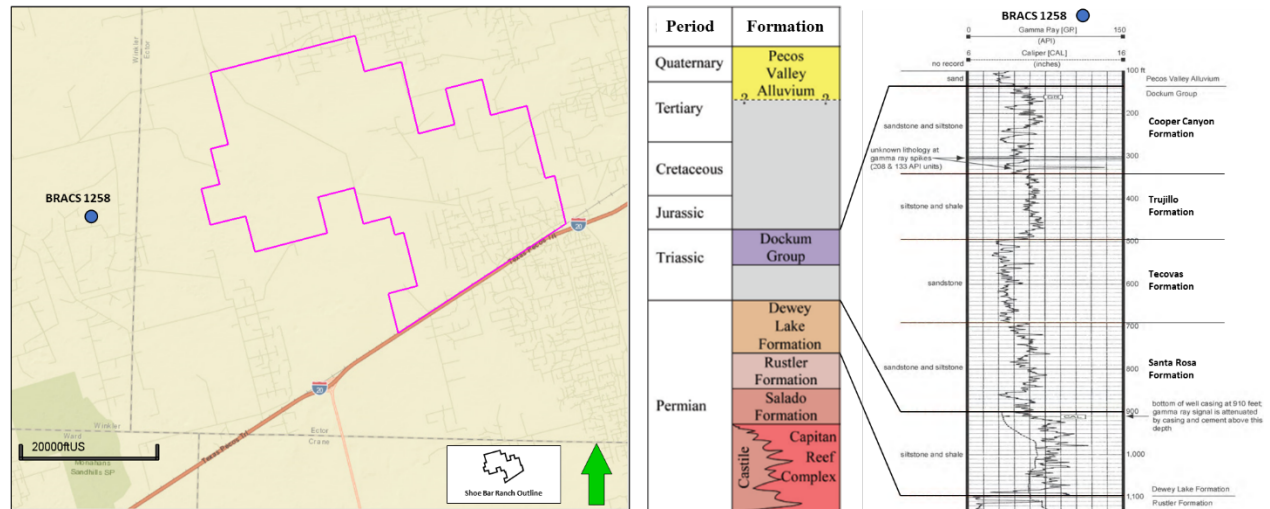

Figure 24—Left: BRACS1258 surface location in relation to Shoe Bar Ranch. Middle: Shallow geology from BRACS well 1258 ~2 miles west of the Project area (stratigraphic column from Meyer 2020). Right: BRACS 1258 well log interpretation from Meyer et al. (2012).

The Triassic Dockum group forms the Dockum minor aquifer and comprises four formations (from oldest to youngest):

1. Santa Rosa Formation consisting of red to red-brown sandstone and conglomerate, which forms the base of the USDW;
2. Tecovas Formation consisting of variegated, sometimes sandy mudstones with interbedded fine- to medium-grained sandstones;
3. Trujillo Formation consisting of gray, brown, greenish-gray, fine- to coarse-grained sandstone and sandy conglomerates with thin gray and red shale interbeds; and
4. Cooper Canyon Formation consisting of reddish-brown to orange siltstone and mudstone with lenses of sandstone and conglomerate (Bradley and Kalaswad 2001).

Hydraulic conductivity of the Dockum aquifer in southwest Ector County is in the range of 0 to 5 ft/D (Ewing et al. 2008).

Drainage of the Pecos Valley and Dockum aquifers from Shoe Bar Ranch is directed towards the Pecos River (30 miles SW), following the Monument Draw Trough (Boghici 1999). This elongated basin is oriented NW-SE with its main axis located in the vicinity of the intersection of Ector, Winkler, Ward, and Crane counties (Ashworth and Hopkins 1995).

The Dewey Lake Formation separates the base USDW from the regional seal and consists of red siltstone and shale (Meyer et al. 2012). The Dewey Lake Formation is not known to yield water to wells (Bradley and Kalaswad 2001) and is not listed as an aquifer by the TWDB. Over 2,500 ft of Rustler through Queen Formation evaporites and regional seal separate the base USDW from the Lower San Andres Injection Zone.

2.3 Geocellular Model Domain

The static geocellular framework was constructed by first modeling large-scale stratigraphic and structural features, and then modeling the petrophysical properties of these geologic features. The first step involved establishing a conceptual structural and depositional model, as well as its characteristic stratigraphic layering. The structural and stratigraphic architecture provided a first-order constraint on the spatial continuity, porosity, permeability, and other attributes within each layer. Next, petrophysical values were distributed for each zone using a cell-based methodology.

The geocellular model comprises the Grayburg and Upper San Andres formations (Upper Confining Zone), the Lower San Andres Formation (Injection Zone) with three sub-zones (G4, G1, Holt), and the Glorieta Formation (Lower Confining Zone). The areal extent of the geocellular model (12×10.8 miles) covers the Shoe Bar Ranch lease plus a 1-mile buffer zone around the lease that allowed for the evaluation of pore space under the entire acreage, while also including the northernmost extent of the nearby Penwell San Andres oilfield and the southernmost extent of the TXL oilfield (Figure 25). Well log data from Penwell Field and TXL Field served as crucial control points for the initial geomodel to inform reservoir statistics of all potential injection and confining zones, prior to the acquisition of our two stratigraphic test wells. These offset logs provided important high-density areal log coverage in the north and southeast, surrounding the sparse data coverage in the western part of the lease. In addition, historical production data from the Penwell field permitted model evaluation via simulation-based history matching.



Figure 25—The Project site encompasses the areal extent of the static geocellular model (solid yellow outline).

The model consists of five horizons with four zones (Figure 26). The four zones from shallow to deep are the Grayburg, Upper San Andres, Lower San Andres (with sub-zones G4, G1, Holt), and Glorieta. The Lower San Andres, which is the proposed Injection Zone, was correlated and defined based on well log correlations from 359 well logs and 624 well tops within the geocellular model area.

The final geocellular model is represented by a 277×240×122 grid in a Cartesian system with 277 grid cells in the I-direction, 240 grid cells in the J-direction, and 122 grid cells in the K-direction, for a total of 8.1 million active grid cells. Grid cell dimensions average 200×200×13 ft.

The dynamic simulations were carried out in 3D using full physics and an equation of state. The dynamic reservoir simulation was performed using the vertically upscaled grid (200×200×26 ft cell size) from the static geocellular model (200×200×13 ft cell size). The areal extent of the geocellular and simulation model is shown in the yellow outline in Figure 25. The simulation model is large enough to capture the full extent of the critical pressure front from injection, but

still retains sufficient detail to simulate the migration and extent of the CO₂ plume accurately during the injection and post-injection periods.

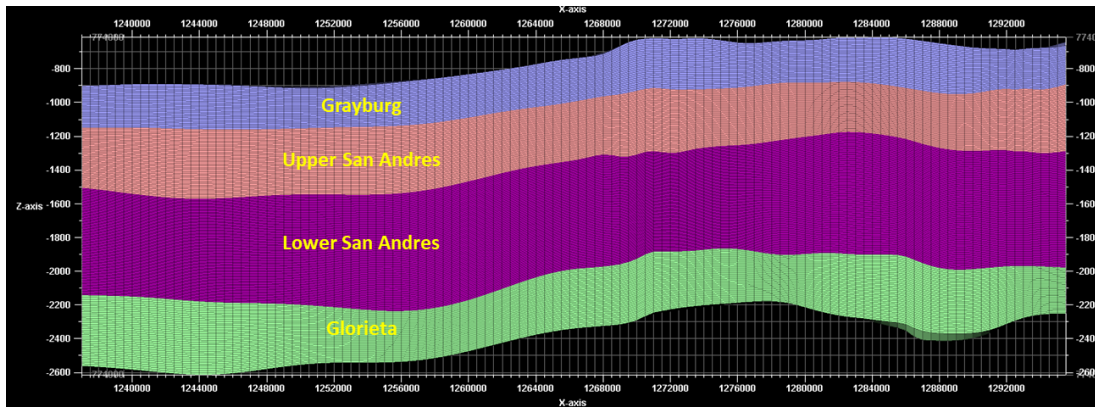

Figure 26—W-E cross section of the static geocellular model zones.

Model domain information is summarized in Table 2.

Table 2—Geocellular Model Domain Information

Coordinate system	SPCS27_4203 (ft US)		
Horizontal datum	NAD27		
Coordinate system units	ft		
Zone	State Plane of Texas Central		
Federal Information Processing Standard (FIPS) ZONE	4203		
Coordinate of X min	1235996.96	Coordinate of X max	1299496.96
Coordinate of Y min	735943.50	Coordinate of Y max	792943.5
Elevation, top of domain	--230.32	Elevation, bottom of domain	-3957.11

2.3.1 Model Geologic Structure

The structural framework of the geocellular model was based on well log correlation within the area, as shown in Figure 27. The structure was mapped based on seismic data and well-based formation tops in areas where seismic data were unavailable. The available 2D and 3D seismic data indicate no faults penetrating the Injection Zone at the Project site (see Section 2.2.5 for a discussion on the acquisition and interpretation of the newly acquired 2D and 3D seismic). Additionally, stratigraphic mapping shows no indications of repeat sections, missing sections, or sharp offsets, which would be characteristic of faults. As such, the geocellular model lacks a fault

property model. Modeled horizons reveal a monoclin dip to the NW, which is consistent with published data about the region (Major et al. 1990, Siemers et al. 1996).

North-south trending, basement-rooted faults were identified during regional interpretation and mapping, but they tip out 1000+ ft below the base of the geocellular model domain. These faults are deep-seated and do not cut through the CO₂ storage complex.

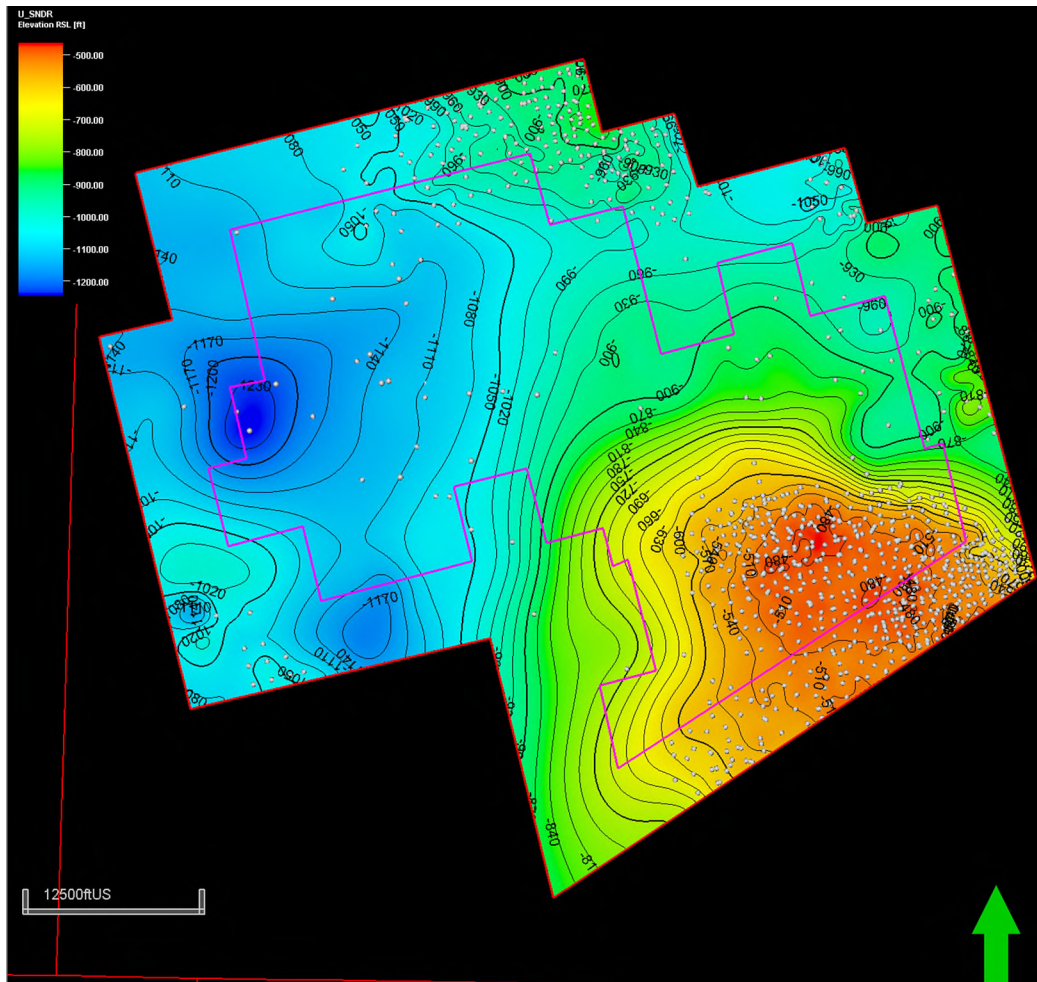

Figure 27—Well top data overlying the Upper San Andres structure at the Project site.

2.3.2 Geocellular Model Zones and Layering

Four zones in the geocellular model were created from stratigraphic surfaces based on well log correlations of formation tops: the Grayburg with mean average thickness of 23 ft, the Upper San Andres with 355 ft, the Lower San Andres with 652 ft, and the Glorieta with 341 ft. Proportional layering was applied to each model zone, and the number of layers within each model zone division was based on the upscaled thickness of each interpreted zone. An index view of the four model zones is shown in Figure 28.

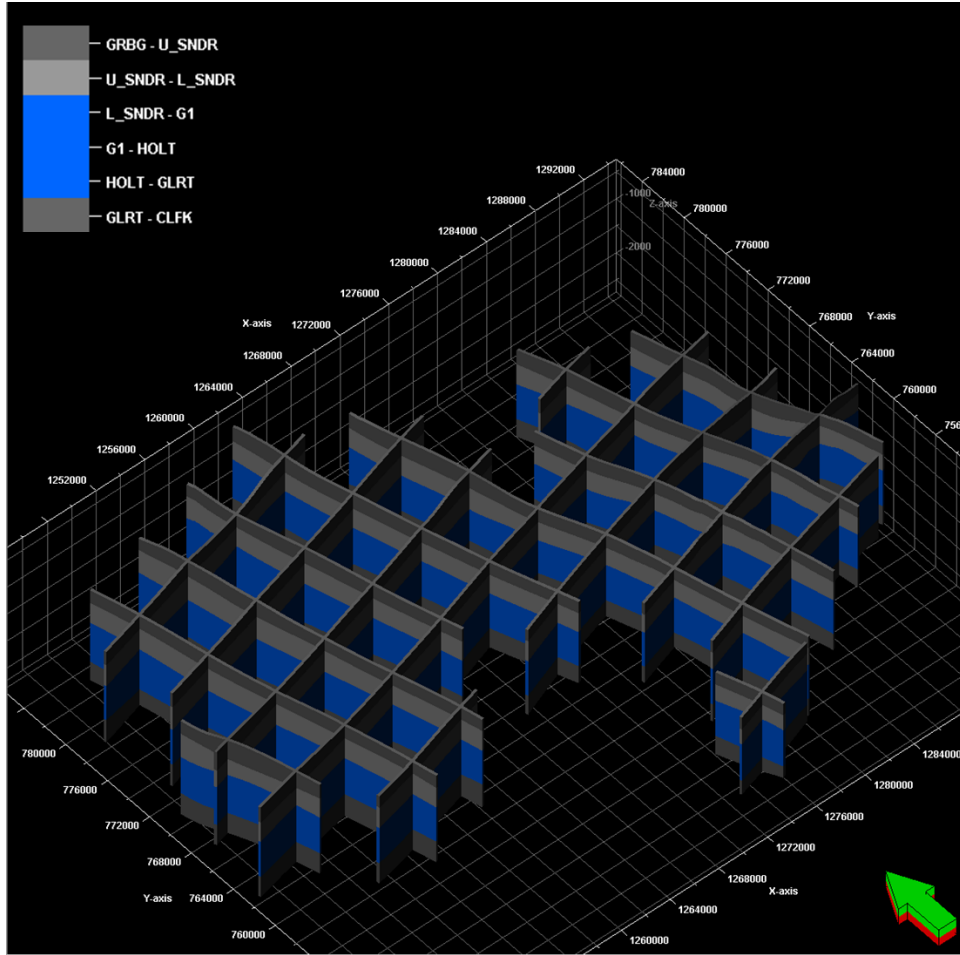

Figure 28—3D index view of geocellular model zones from the Grayburg to Glorieta.

The Lower San Andres Injection Zone is composed of high-porosity and high-permeability (average 8.2 % porosity; 3.4 mD permeability) dolomite layers. The overlying low-permeability layers (<1 mD permeability) within the Upper San Andres and Grayburg Formations correspond to the Upper Confining Zone. Underlying the Lower San Andres is the Glorieta Formation, which represents the Lower Confining Zone (Figure 29).



Figure 29—Composite type well log interpretation from Shoe Bar 1AZ of the Grayburg, Upper San Andres, Lower San Andres, and Glorieta from the AoI. Tracks from left to right show the following: depth, zones, spectral gamma ray and caliper logs, resistivity log, density-neutron-photoelectric factor, lithology, total porosity, and permeability. Gray shading in the Permeability track indicates tight, low-permeability packages.

2.4 Porosity and Permeability

A total of 681 horizontal plugs that are 1.5-inches in diameter were cut from ~714 feet of whole core obtained in the Shoe Bar 1 well. A total of 50 horizontal plugs were cut from ~725 feet of whole obtained in the Shoe Bar 1AZ. Routine core analysis (RCA) was performed to obtain core porosity and core permeability measurements on these 731 plugs. The Project also acquired full-diameter RCA and Mercury Injection Capillary Pressure (MICP) measurements to obtain porosity and permeability data in whole core sections that were cut to 4-inch (diameter) x 6-inch (length) sections and horizontal plug end-trims, respectively.

The resulting core-measured porosity data were used to guide and calibrate the porosity model for deriving log-based porosity estimates as an input to the static geological model. In addition, core-measured permeability data were used to construct a permeability model of Lucia Rock Fabric Number (RFN) for the Injection Zone.

Based on petrophysical analysis of wells within and surrounding the AoR, OLCV identified that the Lower San Andres was the most suitable interval for CO₂ injection based on porosity, permeability, and net thickness (Figure 30).

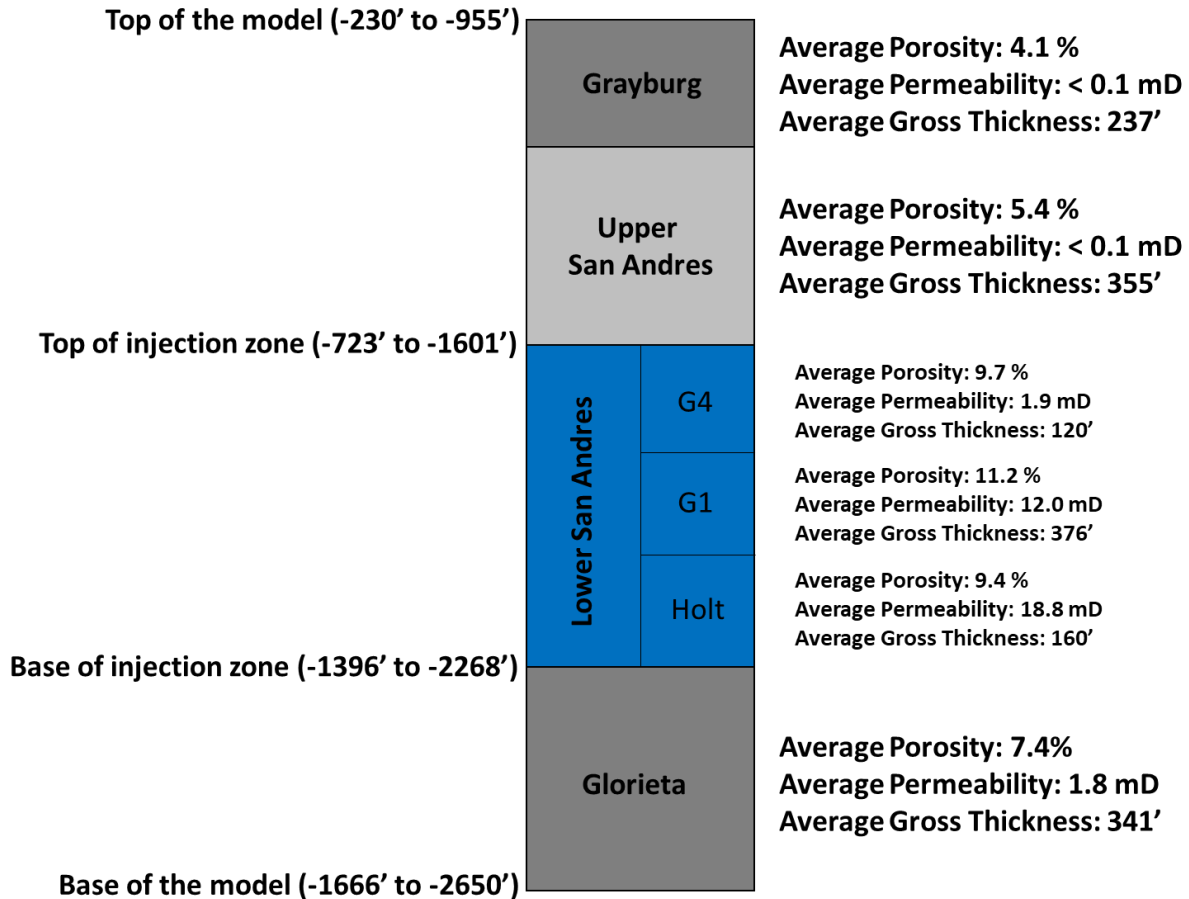

Figure 30—Depth and gross thickness of the geocellular model zones with averages of porosity and permeability based on well log and core analysis of both stratigraphic test wells.

A total of 164 neutron-density calibrated porosity curves (XPOR) that were QCd by qualified OLCV and Oxy petrophysicsts were used for the porosity property in the geocellular model (Figure 31). The Petrel 3D property grids were populated using the following procedure:

1. XPOR curves were upscaled into geocellular model grids at well locations, input parameters were set based upon data analyses, and then porosity was distributed in 3D space using Gaussian Random Function Simulation (GRFS).
2. A moving average simulation of the resulting porosity realization was then used to generate a horizontal trend model. The upscaled XPOR curves were analyzed to create a vertical porosity trend model. The final porosity property was created using GRFS co-kriged with the horizontal and vertical porosity trend models.
3. Permeabilities in the geocellular model were calculated at each cell using the model-zone-specific rock fabric number (RFN) from core-measured porosity and permeability.

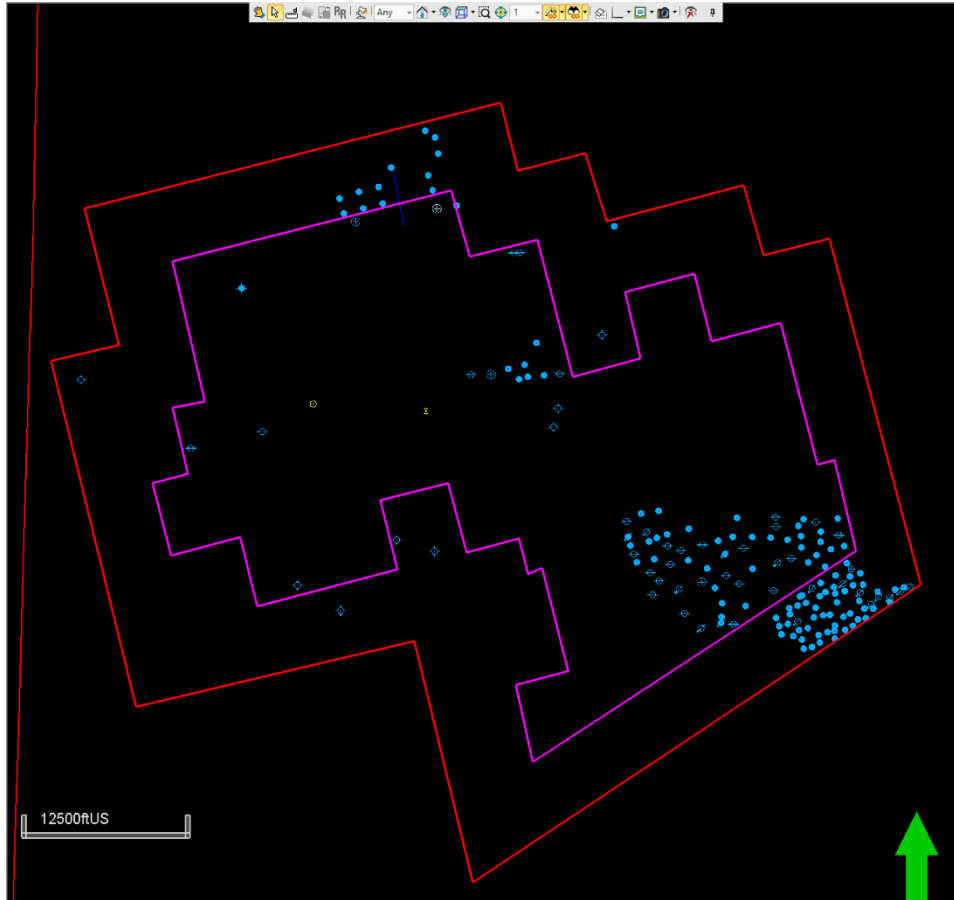

Figure 31—Map view of the 164 petrophysically QCd, neutron-density calibrated porosity log curve control points for porosity modeling.

2.4.1 Porosity

The XPOR porosity logs were upscaled into the 3D grid using an arithmetic method. Data analysis was performed for normal score transform and variogram calculation and fitting. The variogram parameters of type, nugget, sill, and ranges of vertical, major, and minor directions were determined during the variogram fitting process (Table 3). The porosity property was simulated using the GRFS method with fitted variogram parameters, smoothed distribution from upscaled cells, and seed number (Figure 32).

Table 3 —Porosity property parameters

[Redacted Table Content]

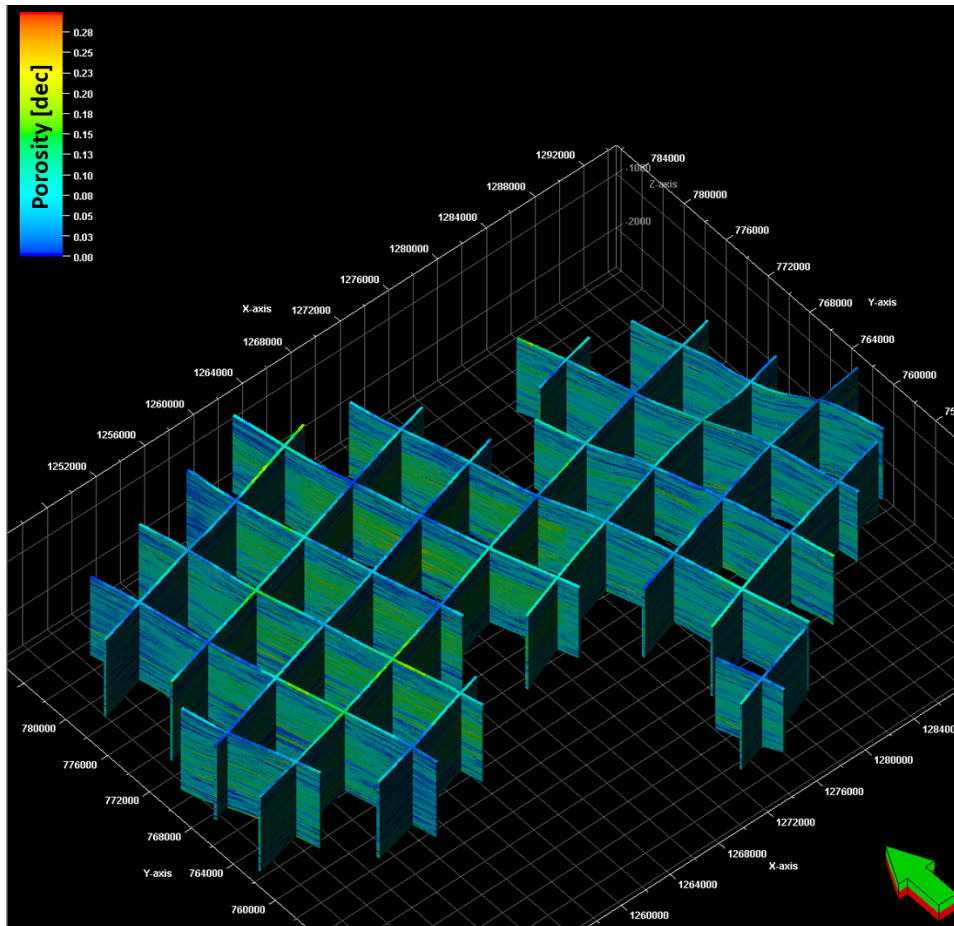

Figure 32—3D porosity distribution index view of the base case porosity.

The degree of uncertainty in the porosity property was quantified using 500 porosity modeling simulation runs. These simulation runs were performed using the same settings and varying seed numbers. The pore volumes were calculated with the 500 porosity properties and ranked from low to high using a percentile ranking (Figure 33). The results showed a tight grouping with pore volume values for P10 and P90 differing from the P50 value by 2.5%, and the P5 and P95 values differing by 4%. To further test the uncertainty ranges, a 0.005 porosity value was added to the P95 porosity property and subtracted from the P5 porosity property. The pore volumes from these two porosity properties are ~10% different from the P50 number. Figure 34 shows cross sections of the porosity property for the P5-0.005, P50, and P95+0.005 cases.

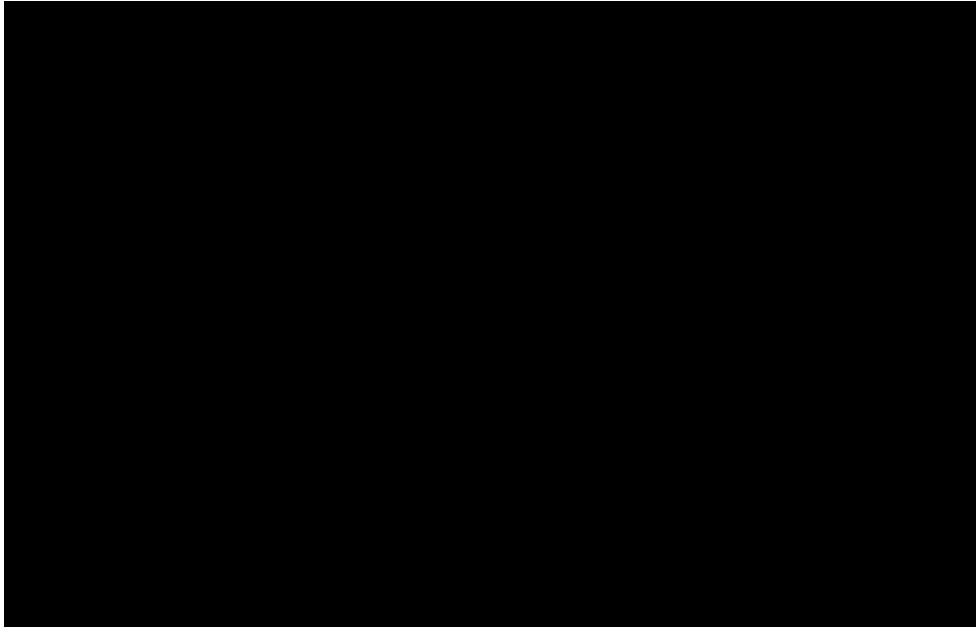

Figure 33—Pore volume distribution of 500 porosity simulation runs with varying seed numbers.

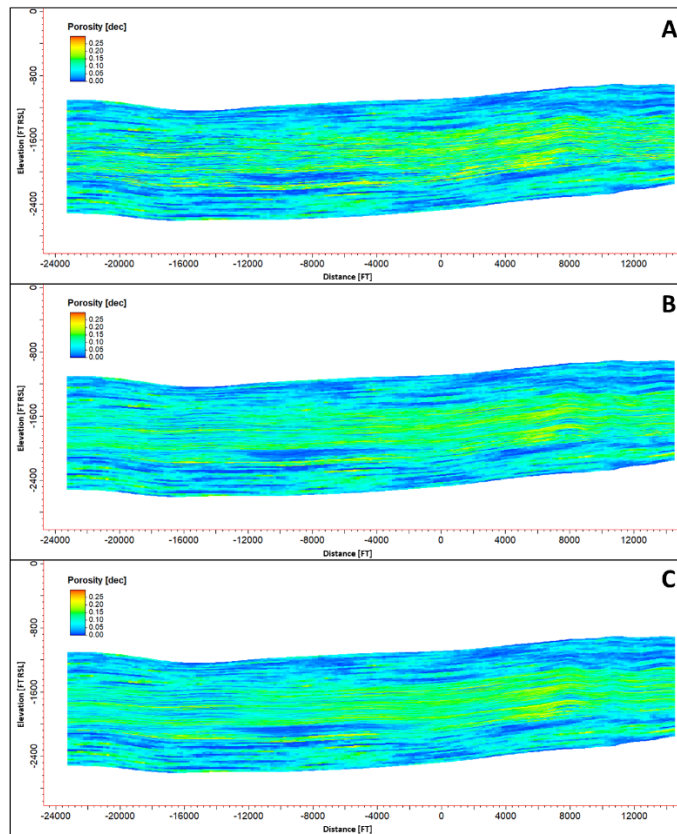

Figure 34—Cross section of the P5-0.005 (A = low), P50 (B = mid), and P95+0.005 (C = high) case porosity.

2.4.2 Permeability

To populate the permeability property in the geocellular model, OLCV:

- Determined horizontal permeability for the Injection Zone based on available core analyses from stratigraphic test wells Shoe Bar 1 and Shoe Bar 1AZ, and
- Developed a core data-based porosity-permeability transform to estimate permeability data outside core data coverage using a Lucia rock fabric number (RFN) modeling approach (Lucia, 1995).

Permeability modeling in dolomite reservoirs presents a challenge due to the varying nature and presence of vugs (connected/isolated) in the matrix. Core analysis from stratigraphic test wells Shoe Bar 1 and Shoe Bar 1AZ revealed strong heterogeneity when comparing porosity and permeability measurements at various scales, i.e., trim ends, plugs, and full-diameter core. OLCV obtained core measurements for porosity and permeability at different scales in two stratigraphic wells. OLCV observed porosity-permeability relationship trends for the G4, G1, and Holt sub-zones in the Injection Zone.

OLCV follows the Lucia rock-fabric method (Lucia, 1983; Lucia, 1995; Lucia, 2007) for carbonate reservoir characterization, which is an industry standard for distributing petrophysical properties (permeability and water saturation) within a lithofacies-constrained, flow-unit scale, reservoir model framework (Figure 35). The Lucia (1983) classification defines three major Rock Fabric Numbers (RFNs), each characterized by distinct petrophysical properties (porosity-permeability, saturation). These are: grainstones (RFN 1), grain-dominated packstones (RFN 2), and mud-dominated packstones, wackestones, and mudstones (RFN 3). Because of variance in pore throat geometry, samples cluster around discrete RFN transforms when porosity and permeability values are cross-plotted on a log-log scale (Lucia, 2007).

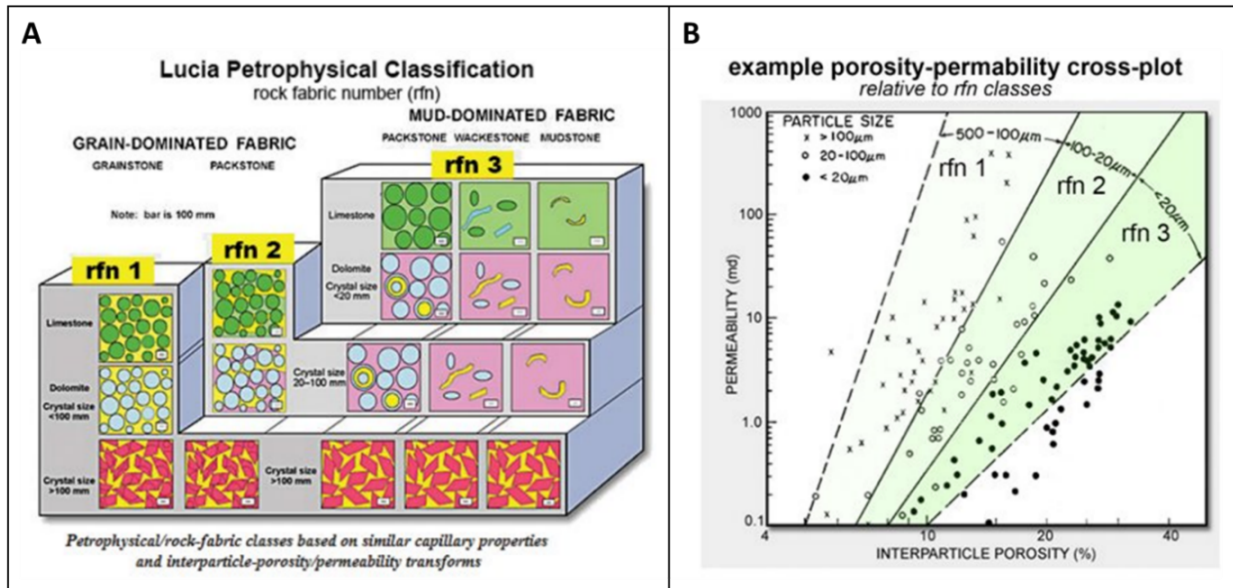

Figure 35—Lucia petrophysical classification diagram (A) and porosity-permeability relationships (B) (Lucia, 2007).

The Lucia Global Permeability Function, shown in Equation 2, is used to calculate permeability from interparticle porosity, using the RFN number.

$$Perm (Lucia) = 10^{((A - B) + ((C - D) * LOG10(\varnothing_{ip})))} \quad \text{Equation 2}$$

where:

- A = 9.7982
- B = 12.0838*LOG10(RFN)
- C = 8.6711
- D = 8.269865*LOG10(RFN)
- RFN = Lucia rock fabric number
- \varnothing_{ip} = Interparticle porosity

The permeability in the upper part of the Injection Zone between the top of the Lower San Andres and the G1 sub-zone (i.e., the G4 sub-zone) was modeled using a RFN of 2.4, shown in Figure 36 below.

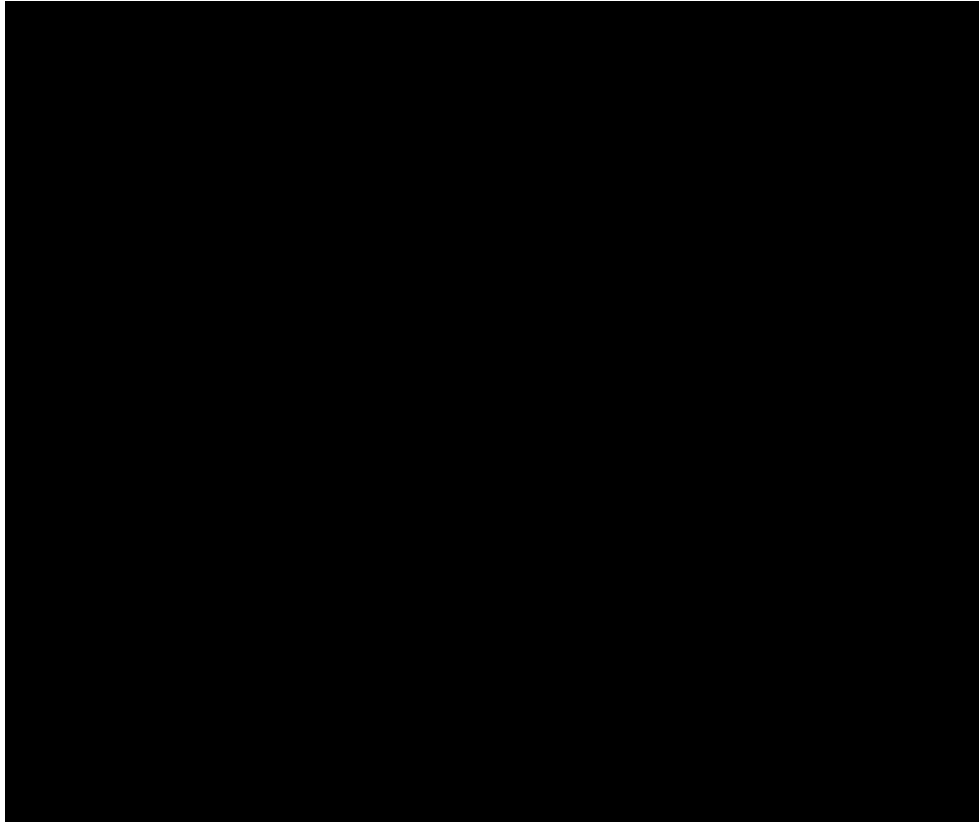

Figure 36—A cross-plot of core porosity and core permeability at different measurement scales for the upper part of the Lower San Andres formation.

The permeability from the top of the G1 sub-zone to the top of the Holt sub-zone (i.e., G1 sub-zone) was modeled using a RFN of 1.8. Figure 37 shows the cross-plot of core porosity and core permeability at different measurement scales for this sub-zone.

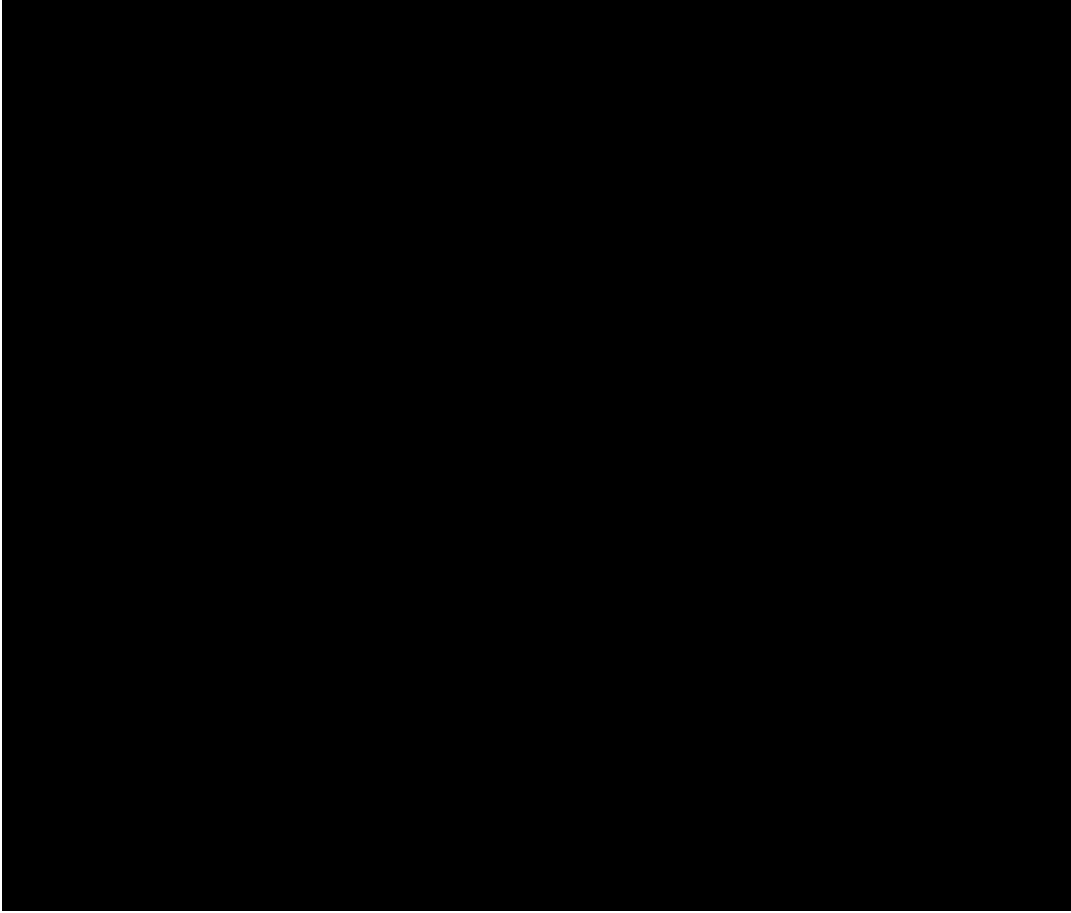

Figure 37—Cross-plot of core porosity and core permeability at different measurement scales for the G1 sub-zone.

The permeability in the sub-zone between the top of the Holt and the base of the Lower San Andres formation (i.e., Holt sub-zone) was modeled using a RFN of 1.6. Figure 38 shows the cross-plot of core porosity and core permeability at different measurement scales for this sub-zone.

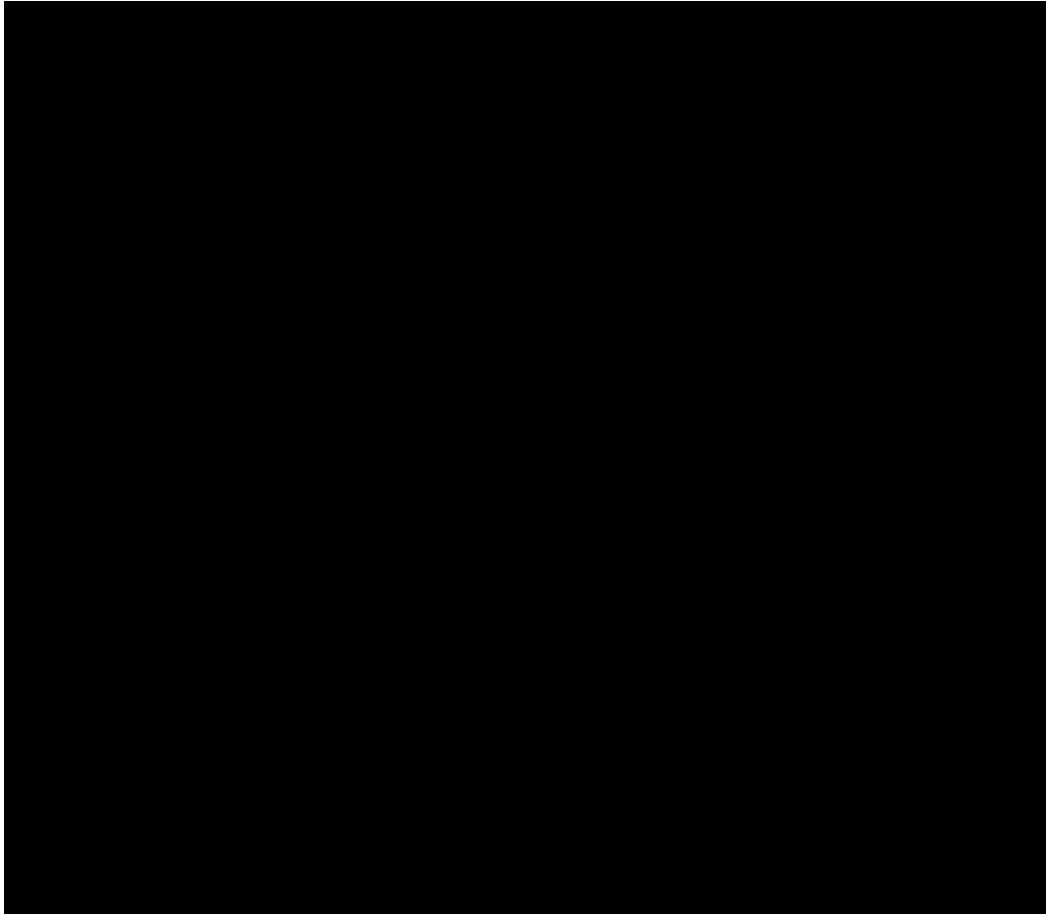

Figure 38—Cross-plot of core porosity and core permeability at different measurement scales for the Holt sub-zone.

The final log-derived permeability for the Injection Zone was computed using the Lucia RFN transform and delivered as in input to the static geological model. The log plot (Figure 39) from Shoe Bar 1AZ shows the match between core measured data (porosity and permeability) and log-derived porosity and log-derived Lucia RFN based permeability (Figure 39).

The correlation log plot in Figure 39 shows an example of the match between core data (porosity and permeability) and log-derived porosity and Lucia RFN permeability in stratigraphic test well Shoe Bar 1AZ (representative of the AOR).

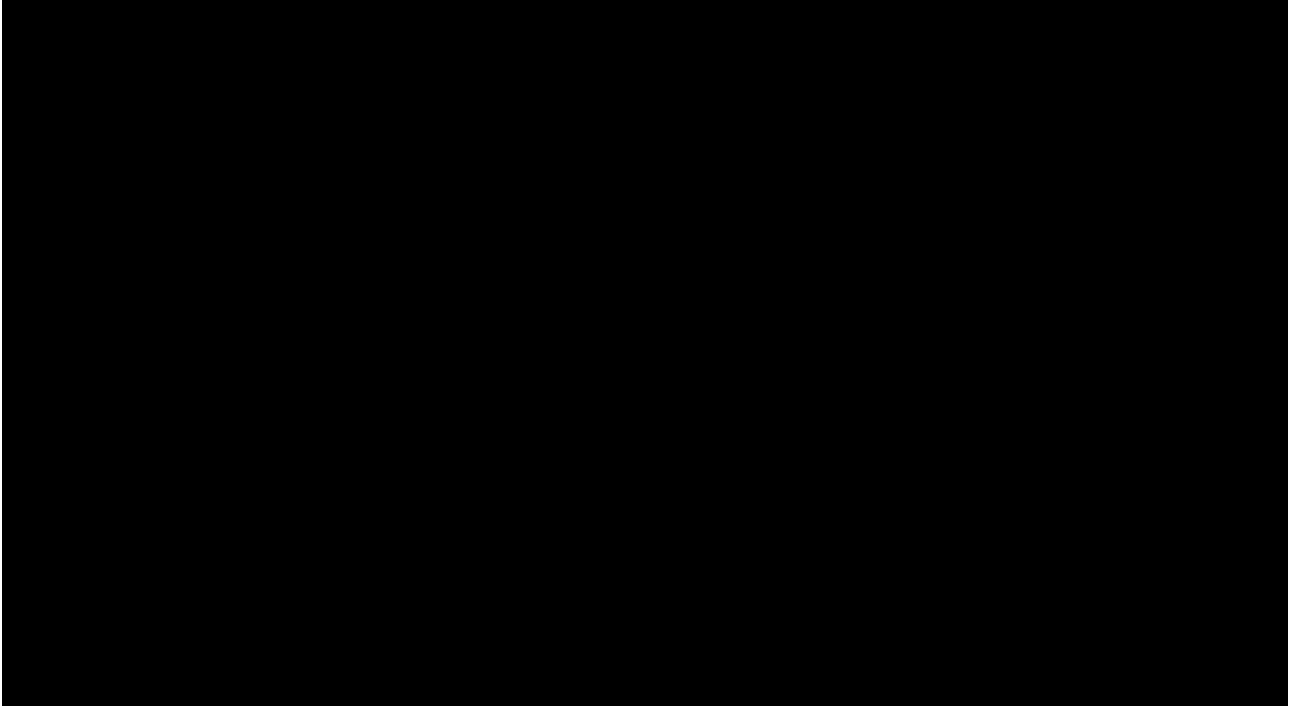

Figure 39—Composite Type well-log interpretation from Shoe Bar 1AZ of the Grayburg, Upper San Andres, Lower San Andres (including the G1, G4, and Holt sub-zones), and Glorieta formations from the AoR. Tracks from left to right show Depth, Stratigraphic Zones, Spectral Gamma Ray and Caliper, Resistivity, Density-Neutron-Photoelectric Factor, Dipole Sonic, Lithology, Total Porosity, Permeability, Grain Density, NMR T2 and NMR Bins. The point data (shaded circles and squares) in tracks 8-10 represent core-measured petrophysical data. Footnote description for Track 8: 1(a)-fractured sample, 1(b)-chipped sample, 1(c)-fractured and chipped sample, 2(a)-sample permeability below measurable range, 22-laminated sample, 7-vuggy sample.



Figure 40—Modeled permeability-porosity cloud transform for sub-zones G4, G1, Holt, honoring their core-derived rock fabric numbers (G4 = RFN 2.4; G1 = RFN 1.8; Holt = RFN 1.6).

Average horizontal permeability in the geocellular model by sub-zone is based on the porosity-permeability transform shown in Figure 40 with the following sub-zone averages: Grayburg Formation Confining Zone: 0.19 mD; Upper San Andres Confining Zone: 0.56 mD; Lower San Andres Injection Zone: 3.4 mD with maximum up to 140 mD; Glorieta Formation Lower Confining Zone: 1.83 mD. Figure 41 shows a 3D fence diagram of horizontal permeability for all the zones.

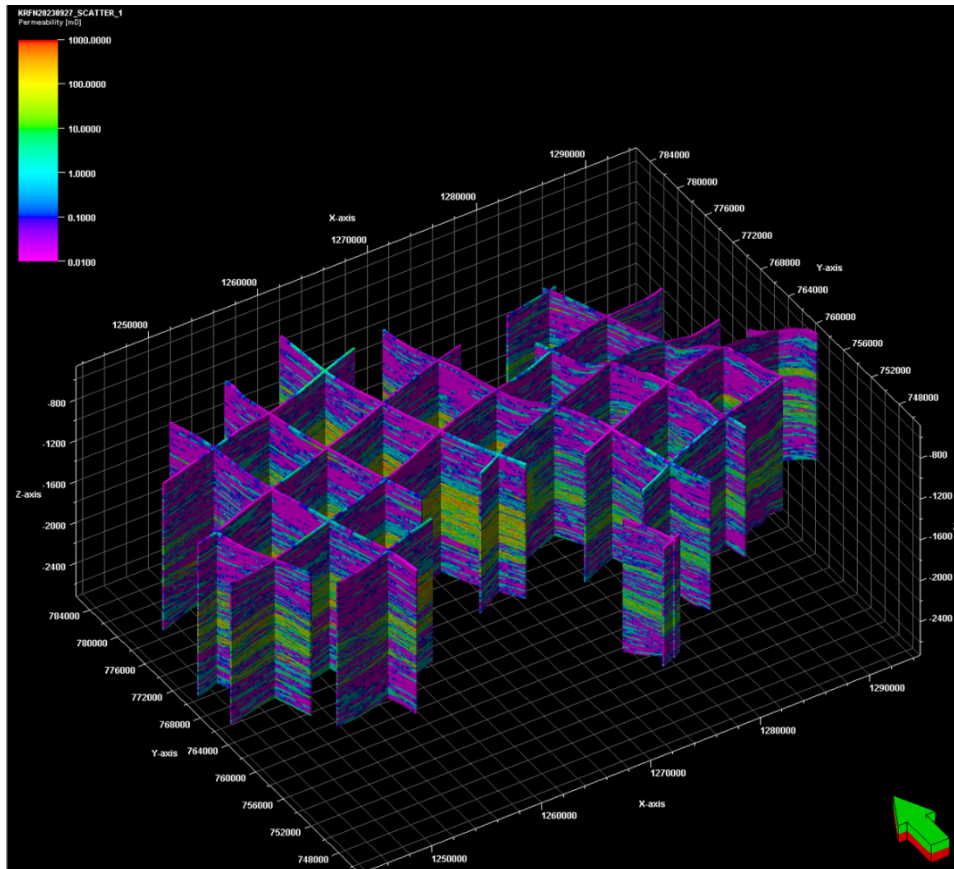

Figure 41—3D index view of the base case permeability distribution calculated using the Lucia transform.

Three permeability transforms, high (P95+0.005), mid (P50), and low (P5-0.005), were calculated from the porosity properties to represent the permeability uncertainty ranges in Figure 42.

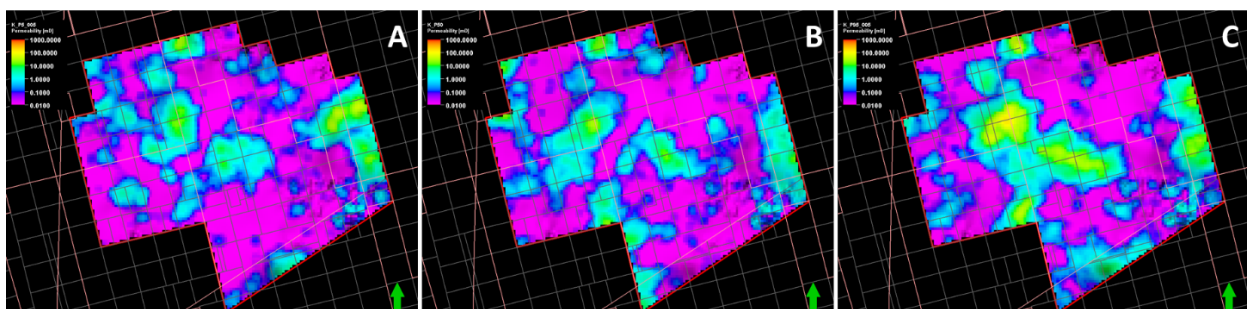

Figure 42—Plan view of the P5-0.005 (A = low), P50 (B = mid), and P95+0.005 (C = high) case permeability.

2.5 Constitutive Relationships and Other Rock Properties

The BRP Project dynamic reservoir simulation followed a method developed by Ghomian (2008), who had successfully matched the results of a 2004 Frio pilot injection test, described in detail by Sakurai et al. (2006). OLCV adopted these established processes for petrophysical evaluations, geocellular model construction, and equation-of-state (EOS) modeling for CO₂ properties and solubility. Further, all simulation runs were executed using the GEM simulator, as used by Ghomian (2008).

The grid properties of porosity and horizontal permeability (k_h) were imported directly from the static geocellular model. The base vertical permeability (k_v) for each grid cell was calculated using a multiplier of 0.1 to the horizontal permeability, based on Oxy's 30 years of experience in building simulation models for more than 20 San Andres reservoirs in the Permian Basin.

The water-gas capillary pressure curves are based on MICP laboratory data presented in Appendix A of this plan. Sample 190H is interpreted to be most representative of the Injection Zone and sample 2-60R is interpreted to be most representative of the Upper Confining Zone. The water-gas relative permeability curves for the respective samples were taken from the analytical workflow based on Greene et al. (2021) and Corey (1954) provided in Appendix A of this Plan. Based on Oxy's extensive experience in the Permian Basin, the maximum relative permeability to gas (k_{rg}) value from experimental results of Bennion (2006) and Lun et al. (2023) was slightly modified to a lower value of 0.4 that represents a conservative scenario. Ranges of relative permeability Corey parameters were tested as a sensitivity to determine the effect on the injection rate and reservoir pressure during injection. Figure 43 shows the capillary pressure and relative permeability curves for Injection and Upper Confining Zone, respectively.

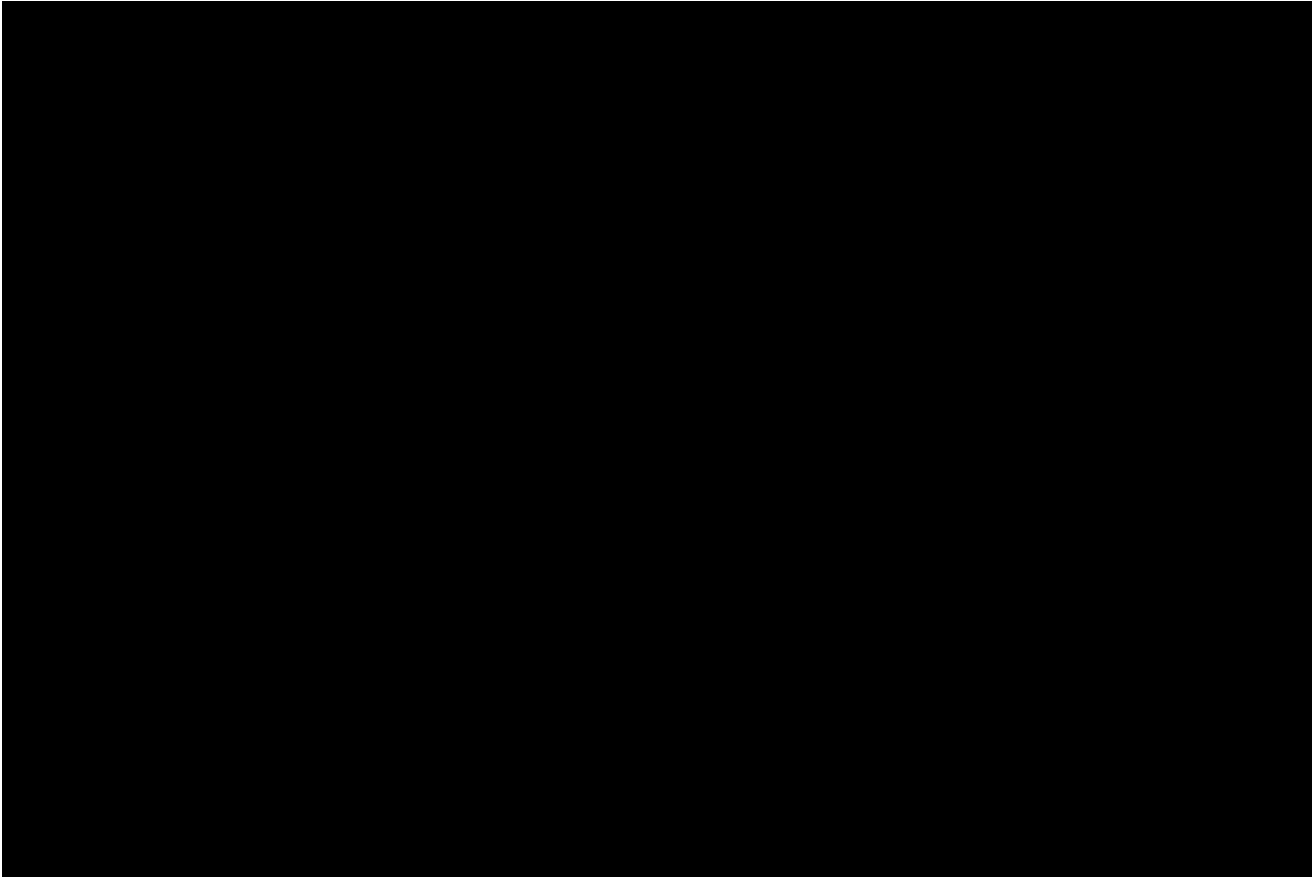

Figure 43—Relative permeability and capillary pressure for the Injection Zone (A) and Upper Confining Zone (B). k_{rw} and k_{rnw} represent the relative permeability for the wetting (water) and non-wetting (gas) phases, respectively.

The fluid and rock properties (water density, salinity, and composition and rock compressibility) used in the simulation model are described in Section 2.3 of this document. The water density variation with depth and pressure were calculated using the linear models reported in GEM, respectively. The water viscosity was estimated using the correlation from Sharqawy et al (2010) at reservoir conditions (salinity and temperature).

2.6 Penwell Field Calibration

Because there is an active San Andres waterflood development in the Penwell field located only five miles away from the proposed BRP Project, OLCV performed a field-level calibration exercise of the Penwell wells that lie within the simulation model's boundaries (Figure 44). The motivation for this was to assess the effect of the Penwell field development on the reservoir pressure in the proposed Injection Zone and to evaluate if the Penwell and the AoI are isolated from each other. The result was a calibrated simulation model that included three leases of the Penwell field: North Penwell unit, East Penwell unit, and Penwell unit (Figure 44).

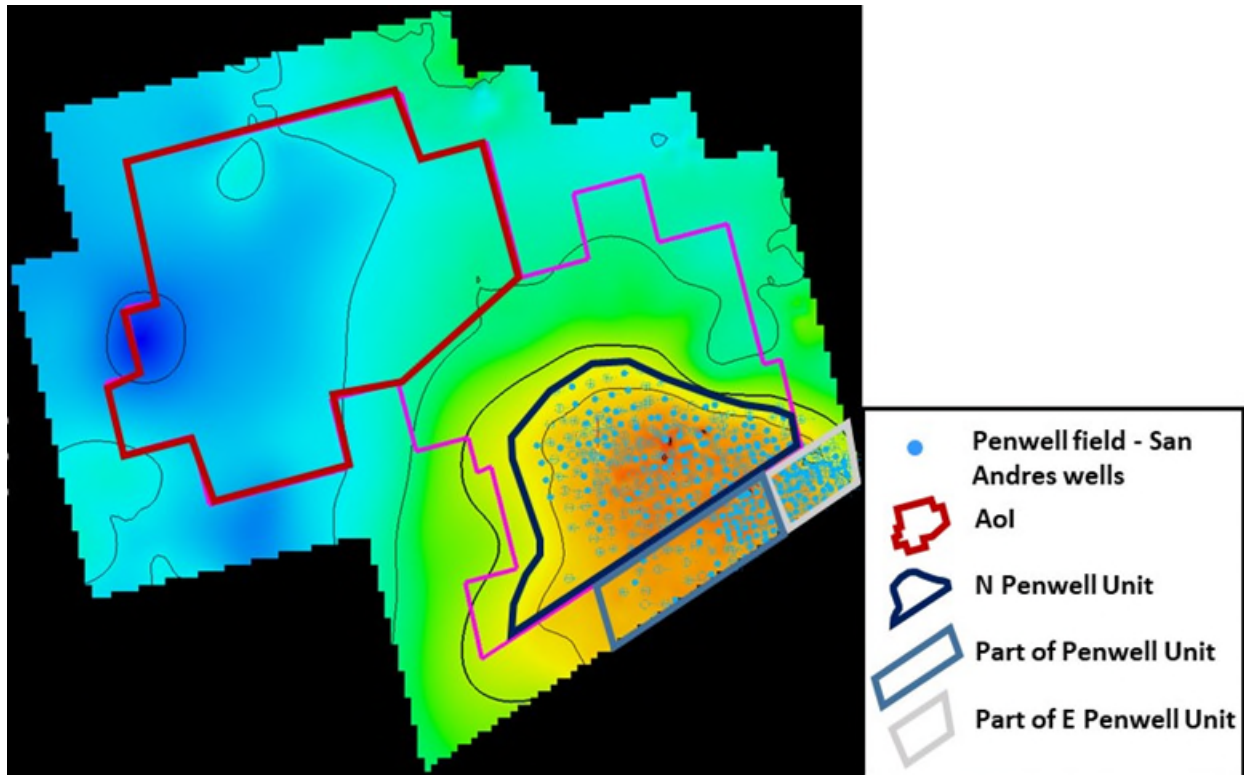

Figure 44—Areal view of the Project site showing the model, existing wells in the Penwell field, and the BRP AoI

The historical reservoir pressure information of the North Penwell field was obtained from the North Penwell unitization agreement (Figure 45). The original reservoir pressure was 1,600 psig, with the main drive mechanism being solution gas drive because there was no apparent gas cap. The saturation pressure was listed as 1,226 psig. Information obtained from Major et al. (1990) suggests that the Upper San Andres is the hydrocarbon-bearing reservoir out of which only the upper oil-producing zone was predominantly exploited (Siemers et al. 1996). The initial water saturation in the Upper San Andres or hydrocarbon-bearing zone was populated using the Lucia correlation (1995). Historical production and injection data from public databases (TRRC) indicate that the Lower San Andres is a non-oil-bearing zone. These public data were used in the field-level model calibration exercise.

Plan revision number: 3
 Plan revision date: 07/30/2024

1. Field Name (as per current proration schedule - including reservoir, if applicable.) Penwell		2. RRC District 8	
3. Operator Phillips Petroleum Company		4. County Ector	
5. Lease Name(s) and RRC Lease Number(s) North Penwell Unit		6. Reservoir Discovery Date 1927	
7. Have any injection permits been granted previously to any operator in this reservoir? <input checked="" type="checkbox"/> Yes <input type="checkbox"/> No If answer to this question is "NO", ALL OPERATORS IN THE RESERVOIR MUST BE NOTIFIED of this application, and copies of notification attached hereto.			
8. Check the Appropriate Block(s): <input checked="" type="checkbox"/> New Project or <input type="checkbox"/> Expansion of Previous Authority to Add Either: <input type="checkbox"/> New Lease(s) or <input type="checkbox"/> Additional Well(s) on Same Lease(s) Previous Authority Dated _____ by <input type="checkbox"/> Administrative Action or <input type="checkbox"/> Hearing. Special Order No. _____			
RESERVOIR AND FLUID DATA ON ENTIRE RESERVOIR			
9. Name of Reservoir San Andres		10. Estimated Productive Area of Entire Reservoir (acres) 11,000 acres	
11. Composition (sand, limestone, dolomite, etc.) Dolomite with gypsum and anhydrite		12. Type of Structure (include cross-section and structural maps.) Anticline	
13. Subsea Depth of Oil-Water Contact (ft.) -1095'		14. Subsea Depth of Gas-Oil Contact (ft.) None apparent	
15. Original Bottom Hole Pressure (psig) 1600		16. Current Bottom Hole Pressure (psig) 350	
17. Was a Gas Cap Present Originally? No		18. Is a Gas Cap Present Now? No	
19. Ratio of Gas Cap Volume to Oil Zone Volume ---		20. Saturation Pressure (psig) 1226	
21. Formation Volume Factor Original: 1.22 Current: 1.16		22. Type Drive During Primary Production Solution gas	
RESERVOIR AND FLUID DATA			
23. Number of Productive Acres in Lease(s) within Project Area 4354		24. Average Depth to Top of Pay (ft.) 3400'	
25. Average Horizontal Permeability (md.) 2.5		26. Average Effective Pay Thickness (ft.) 51	
27. Average Porosity (%) 9.8		28. Connate Water Saturation (% of pore space) 35	
29. Range of Horizontal Permeability (md.) ---		30. Gravity of Oil (deg. API) 33	
31. Viscosity (cgs. @ °F) 1.6			
PRODUCTION HISTORY OF RESERVOIR			
32. Date First Well Completed on Lease(s) 1930		33. Stage of Primary Depletion of Project Area 81%	
34. Current Average Gas-Oil Ratio (SCF/bbl.) 2000		35. Current Water Production (% of total fluid production or bbls./day) 28%	
36. Current Number of Producing Wells on Each Lease in Project Area 114		37. Current Average Daily Oil Production per Well (bbls./day/well) 8	
38. Cumulative Oil Production to Date from Lease(s) (bbls.) 7,697,826 (1-1-70)		39. SUBMIT ATTACHED SHEET(S) GIVING THE OIL, GAS, & WATER PRODUCTION BY YEARS SINCE DISCOVERY & TOTALS. FOR THE LAST 3 YEARS, GIVE THESE FIGURES BY MONTHS.	
TYPE OF INJECTION PROJECT AND RESULTS EXPECTED			
40. Type of Injection Project (Check the appropriate block(s): <input checked="" type="checkbox"/> Waterflood, <input type="checkbox"/> Miscible Displacement, <input type="checkbox"/> Thermal Recovery, <input type="checkbox"/> Pressure Maintenance, <input type="checkbox"/> Other _____ (specify)			
41. Current Estimated Oil Saturation (% of pore space) 55		42. Estimated Residual Oil Saturation at Abandonment (% of pore space) 40	
43. Estimated Original Oil-In-Place (bbls.) 103,858,827		44. Estimated Ultimate Additional Oil that will be Recovered as a Direct Result of Injection (bbls.) 4,703,890	

Figure 45—North Penwell Unit information obtained from the unitization agreement (Source: TRRC).

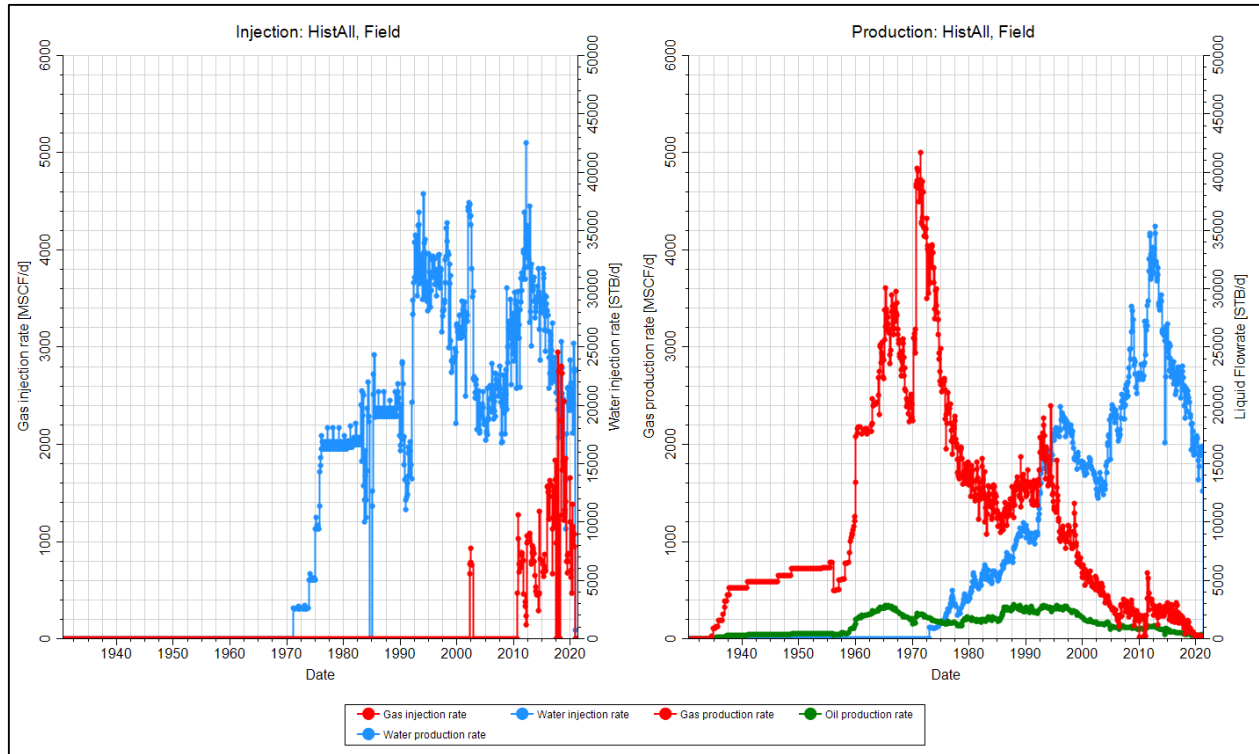

Figure 46—Historical injection and production of the Penwell field.

Figure 46 shows the historical production and injection data for the Penwell wells inside the model boundaries. For this exercise, a black-oil model was deemed suitable. Therefore, the black-oil pressure-volume-temperature (PVT) data were taken from an analog San Andres field operated by Oxy. Horizontal permeability distribution, the relative permeability endpoints, and the Corey exponents were tuned to obtain a field-level history match of the model from August 1930 to May 2021 (Figure 47).

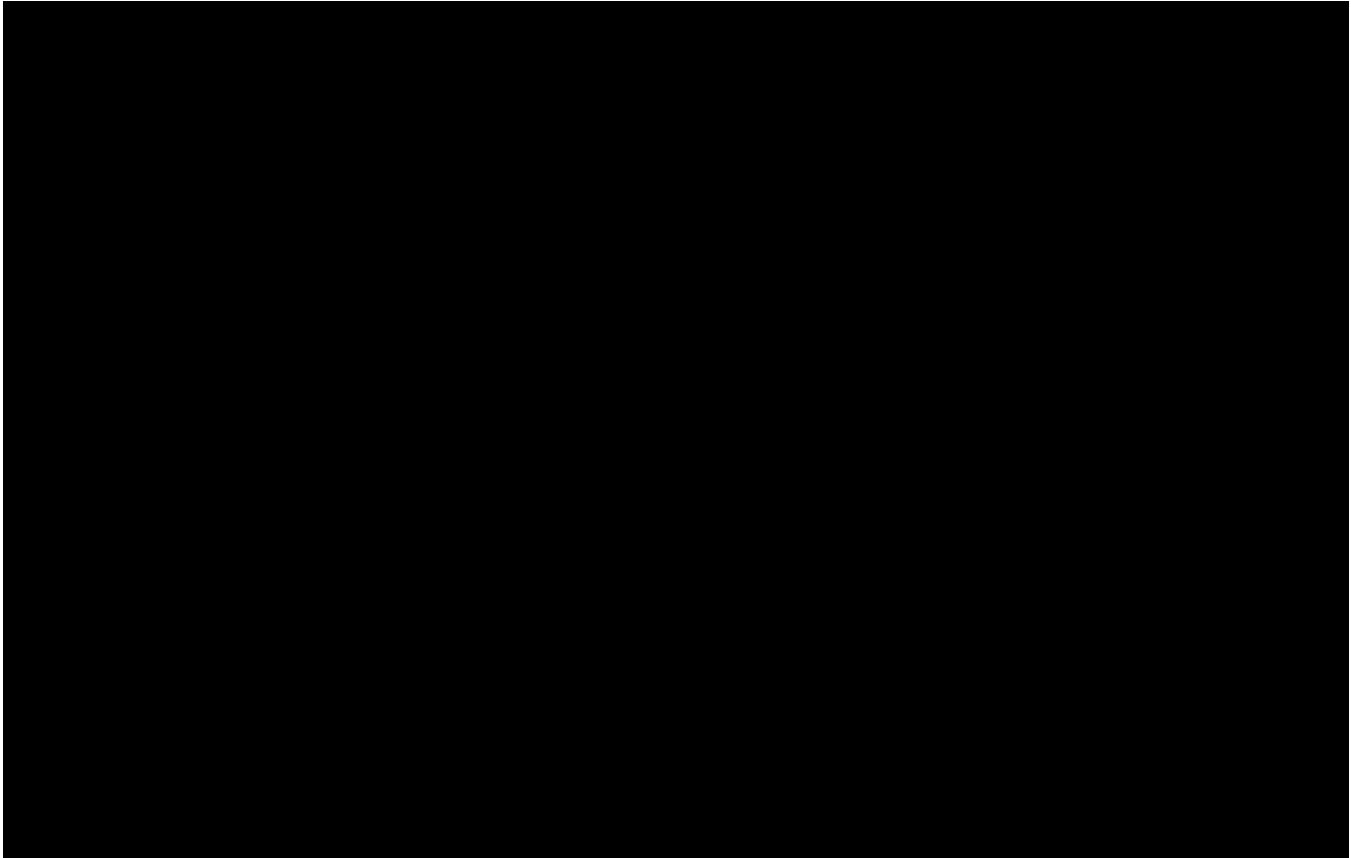

Figure 47—Predictions from the history-matched Penwell model.

The tuned relative permeability exponents are listed in Table 4, and the calibrated permeability in the X- and Y-directions are shown in . The permeability distributions are shown as vertically averaged maps for the Upper San Andres Formation. It can be observed that the predominant change in permeability happened in the X-direction, consistent with the E-W direction of the maximum horizontal stress.

Table 4—Tuned Relative Permeability Data for the Penwell History-Match Model

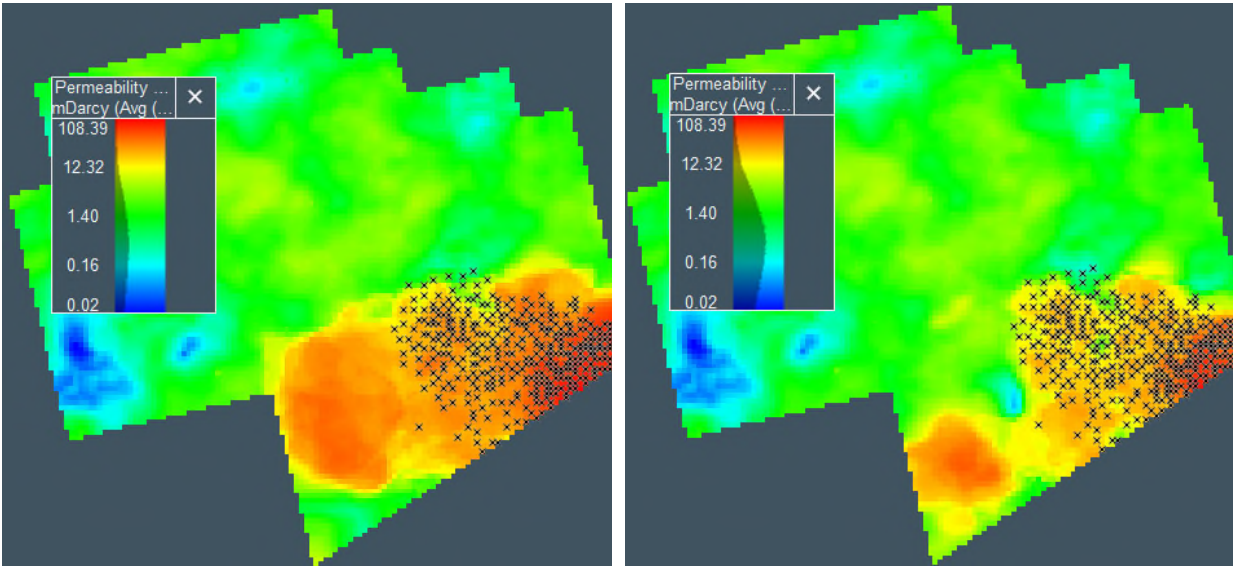

Figure 48—Left: Vertically averaged permeability in the X-direction. Right: Vertically averaged permeability in the Y-direction.

Figure 49 shows the reservoir pressure distribution at the end of the calibration period (May 2021); it shows that the pressure propagation also follows the direction of permeability modification. To assess the effect of Penwell field development on the reservoir pressure of the proposed sequestration AoI, a monitoring well was placed in the history-matched model (Figure 49). shows the well-block pressures of the monitoring well perforated in the Upper and Lower San Andres, respectively. The pressure effect on the AoI due to Penwell development is negligible—around 3 psia in Lower San Andres and 1 psia in the Upper San Andres, over the entire 91-year history of the field.

Pressure gauge measurements obtained in the Lower San Andres from the Shoe Bar 1 well support the hypothesis that Penwell field is not in communication with the BRP site. A downhole pressure gauge in the Shoe Bar 1 well between March – November 2023 has shown a consistent pressure gradient. OLCV will monitor future operation conditions in the North Penwell unit and adjust the simulation model if needed.

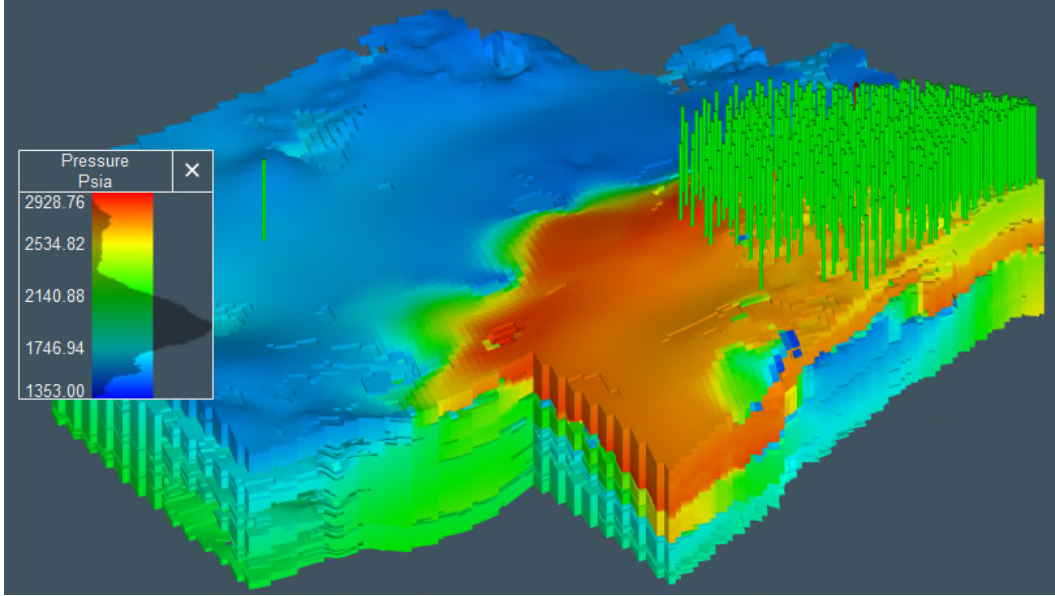

Figure 49—Reservoir pressure at the end of Penwell field calibration period.

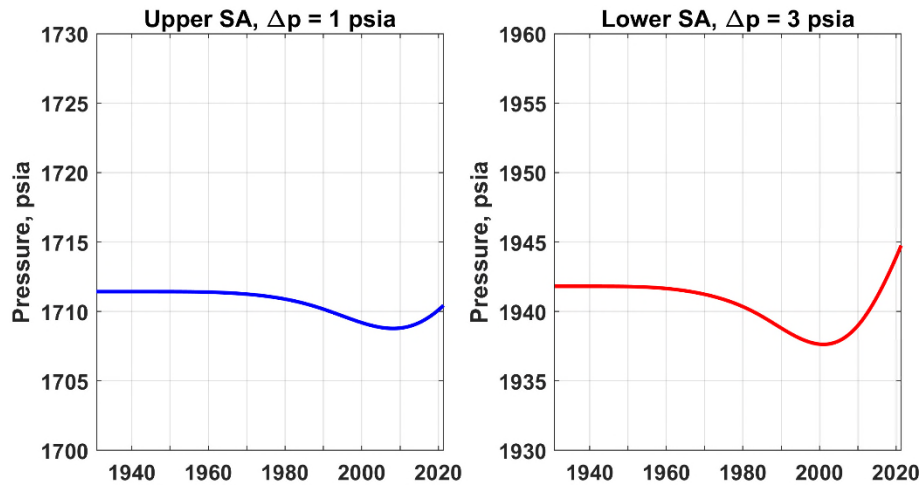

Figure 50—Well-block pressure of the monitoring well in the AoI.

2.7 Boundary Conditions

No-flow boundary conditions were applied to the upper and lower boundaries of the model, with the assumption that the Injection Zone and Confining Zones are continuous throughout the region. This hypothesis is attributed to the large entry pressure observed in the capillary pressure data (i.e., Figure 43) retrieved from MICP experiments (Section 3.4 in Appendix A, Results of Stratigraphic Test Wells). Further discussion regarding geology site specific to justify the no-flow boundary can be found in Section 2.2.3.3 (Upper Confining Zone) and Section 2.2.3.5 (Lower Confining Zone).

The side boundary conditions were also assumed to be no-flow. However, the side boundary condition was tested as a sensitivity to determine the effect on the injection rate and reservoir pressure during injection. As mentioned in Section 2.6, the hydrocarbon development in the Penwell field was not included in the CO₂ injection forecast due to negligible pressure effect of the ongoing waterflood operation on the proposed Project.

2.8 Initial Conditions

OLCV used MDT data obtained in the Shoe Bar 1 to determine the pre-injection pressure vs. depth. The model was initialized with a unit water saturation ($S_w = 1$), because the Lower San Andres Injection Zone is a saline aquifer. According to pyrolysis experiments conducted for the fluid samples acquired from Shoe Bar 1 (Appendix A Section 3.2), there is no evidence of hydrocarbons in the sequestration site. Water salinity measurements were obtained from water samples collected in the Shoe Bar 1. A brine sample representing the middle of the Injection Zone was used for the salinity value in the model. Additional details on data obtained from Shoe Bar 1 are presented in Section 2.3 of this document and in Appendix A.

Table 5—Initial Model Conditions

Parameter	Value or Range	Units	Depth (ft TVD)	Data Source
Temperature	96 to 98	°F	4,393 to 6,486	Measured
Pressure	Spatially varying	psi	4,393 to 6,486	Measured
Fluid density	69.03	lb/ft ³	4,769	Measured
Salinity	130,000	ppm	4,769	Measured
Formation compressibility	4.5E-6	1/psi		Analog San Andres reservoir

2.9 Operational Information

The simulation model forecast (CO₂ injection and water production) begins by using reservoir pressure data based on data acquired in the Shoe Bar 1 and Shoe Bar 1AZ wells. To delineate the BRP AoR, the simulation model considers the influence of the CO₂ injection and water production forecast from the BRP AoI. The simulation model assumes North Penwell Unit will operate at an injection/withdrawal ratio (IWR) of 1.0, and as a result, the waterflood will not influence reservoir pressure in the AoI.

One slant and one horizontal injector (BRP CCS1 and BRP CCS2 wells) will inject at a total maximum group rate of 1,058 MTPD between January 2025 to December 2026 (0.385 MMTPA). BRP CCS1 slant injector is completed in the upper porosity packages (sub-zone G1 and G4) of the Lower San Andres Formation (approximately 360 ft gross thickness in the G1 and 125 ft gross thickness in the G4) and the BRP CCS2 horizontal well is completed at the Holt sub-zone of the Lower San Andres (approximately 170 ft gross thickness).

A third slant injector, BRP CCS3, will commence injection in January 2027. The BRP CCS3, combined with BRP CCS1 and BRP CCS2, will be injecting at a total maximum group rate of 2,116 MTPD from January 2027 to January 2037 (0.772 MMTPA). BRP CCS3 slant injector is completed in the upper porosity packages of the Lower San Andres Formation (sub-zone G1 that is approximately 390 ft thick and G4 that is approximately 130 ft thick).

The slanted injectors have a secondary bottomhole injection pressure (BHIP) constraint of 2,625.3 psig that is set at a reference depth of 4,610 ft TVD. The BHIP for the horizontal well is 3,391.8 psig, and it is set at a reference depth of 5,115 ft TVD.

All wells continue injection until January 2037 when they are shut in. The simulation continues for another 50 years post-injection to simulate CO₂ migration after post-injection site closure.

To restrict the size of the pressure plume resulting from CO₂ injection, four water (brine) withdrawal wells will be drilled and perforated in the Lower San Andres Formation. These wells are planned to commence water withdrawal in July 2024. The minimum BHP of the producers is set at 485.3 psig at a reference depth of 4,610 ft TVD. Between July 2024 to December 2026, the wells produce at a total maximum group rate of 10,000 stb/day; and from January 2027 to January 2037, the wells produce at a total maximum group rate of 15,000 stb/day. The produced brine will primarily be used for Oxy's Enhanced Oil Recovery Operations (EOR) or other makeup water needs. Some of the brine may be injected into Class I disposal wells or utilized in desalination operations. Brine produced from the Project will not be injected into Class II Saltwater Disposal Wells (SWD).

Details of the planned injection and withdrawal wells are presented in Table 6.

Table 6—Operating Details for the Planned Injection and Withdrawal Operation

Operating Information	BRP CCS1	BRP CCS2	BRP CCS3	WW1	WW2	WW3	WW4
	Location (global coordinates, NAD27)						
Latitude	31.76479	31.76994	31.76031	31.76289	31.78419	31.75008	31.76384
Longitude	-102.7289	-102.7332	-102.7102	-102.6959	-102.7276	-102.7102	-102.7540
	Model coordinates (Texas State Plane, Central Zone, USft, NAD27)						
X	1255500	1254200	1261299	1265742	1256211	1261199	1247718
Y	771100	773000	769345	770190	778193	765626	770922
Perforated Interval (ft MD) *							
MD top	4,674	5,768	5,244	4,342	4,468	4,352	4,542
MD bottom	5,667	9,165	6,284	4,982	5,139	4,993	5,201
Wellbore diameter (in) *	6	6	6	6	6	6	6
Planned injection period	1-Jan-2025 to 1-Jan-2037						
Planned water production period	1-Jul-2024 to 1-Jan-2037						
Duration (years)	12	12	10	12.5	12.5	12.5	12.5
Group injection rate (MTPD)	1058 (January 2025 to December 2026) 2116 (January 2027 to January 2037)			-			
Daily average injection mass (MT/day)	450	1,112	450	-			
Daily maximum injection mass (MT/day)	600	1,500	600	-			
Total injection volume and mass (MMT)	1.83	4.87	1.77	-			
Maximum injection BHP (psig)	2,625.3	3,391.8	2,625.3	-			
Average injection pressure (psig)	2,600.3	3,300	2,600.3	-			
Group production rate (stb/D)	-			10,000 (July 2024 to December 2026) 15,000 (January 2027 to January 2037)			
Minimum production BHP (psig)	-			485.3			

*Represents measured depth (MD) along the deviated wellbores (not SSTVD) and diameter in the model, not final wellbore design.

2.9.1 State of Stress and Critical Stress Analysis

The risk associated with fault initiation or reactivation during or after CO₂ injection can be assessed by estimating long-term pressure changes in the subsurface and the potential to induce dilation, or shear slip, on matrix rock and/or pre-existing faults and fractures (Fjaer et al. 2008). The resolved normal and shear stresses acting on an existing or potential fault surface are calculated and utilized in Mohr-Coulomb analysis (Jaeger and Cook 2007) to estimate the risk of failure during CO₂ injection. Uncertainties of inputs to the in-situ stress model increase the risk due to the decreased accuracy and precision of stress magnitudes and the injection pressures required to induce tensile or shear failure. The uncertainties in the stress analysis can be reduced with the acquisition of modern density and dipole sonic data, rock mechanical core data, and an estimate of SHmin through the interpretation of leak-off test (LOT) results to define closure pressure, parting pressure from step-rate tests, or some other means to estimate the minimum horizontal principal stress for model calibration.

The increase in fluid pressure from CO₂ injection has the potential to cause failure from the generation of fractures in the matrix of the formation, dilation or shear slip along pre-existing faults, and/or reactivation of the basement fault systems producing induced seismicity. Mohr-Coulomb failure analysis can be applied in the AoI to evaluate CO₂ injection induced seismicity, reactivation of existing faults, and breakdown of the formation. Mohr-Coulomb failure analysis considers the ratio of shear stress (τ) and effective normal stress (σ_n') acting on a plane in a given orientation compared to the amount of friction of that plane. The plane can be an existing fault surface or a potential failure plane in the matrix of the subsurface. The coefficient of friction (μ) is defined as the ratio of shear stress to effective normal stress:

$$\mu = \frac{\tau}{\sigma_n} \quad \text{Equation 3}$$

In the Mohr-Coulomb failure criterion, failure is defined as the condition in which the shear stress/effective normal stress ratio, acting on an optimally orientated plane, exceeds the failure limit defined by the relationship:

$$\tau = \mu\sigma + S_o \quad \text{Equation 4}$$

where S_o is cohesion and is a function of friction and unconfined compressive strength (UCS):

$$UCS = 2S_o(\sqrt{\mu^2 + 1} + \mu) \quad \text{Equation 5}$$

Figure 51 shows the conceptual graphical representation of the linear Mohr-Coulomb failure criterion. The state of stress is represented by the Mohr circle defined by the maximum (σ_1) and minimum (σ_3) principal stresses. Any plane orientation is defined along the boundary of the circle by an angle of 2β from σ_1 to σ_3 , where β is the angle between the σ_1 and the normal the plane. In

Figure 51, the red circle represents the original state of effective stress. In the case of CO₂ injection into the reservoir, pore pressure is estimated to increase while the magnitude of the effective principal stresses decreases, which moves the Mohr circle to the left on the X-axis. The failure limit is shown as the linear-sloped solid black line defined by Equation 4. The dashed line would represent the failure limit of a pre-existing fault with comparatively little friction. While the friction of faults is not zero, it is small compared to the friction required to initiate a fracture in the matrix.

As pore pressure increases during injection, the Mohr circle moves to the left along the X-axis and the boundary of the circle eventually intersects the failure envelope. Under those conditions, any plane orientated along the Mohr circle that crosses or intersects the failure envelope may be subject to failure risk. The linear model presented below represents a simplified version of the Mohr-Coulomb failure criterion because the failure envelope is not often linear, and as pore pressure increases, the effective stress decreases, but the horizontal principal stress magnitude increases, making the circle smaller. The result of the linear model is a conservative interpretation, which is appropriate in a scenario where large uncertainties exist in the stress model.

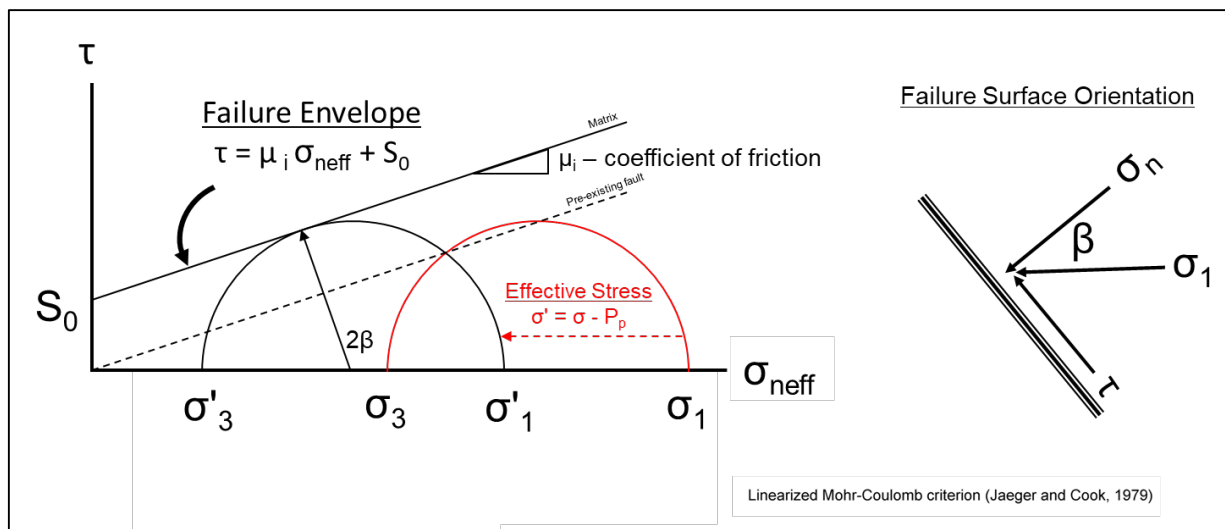

Figure 51—Graphical representation of the linear Mohr-Coulomb failure criterion.

Effective stress calculations in a Mohr-Coulomb analysis depend on an empirical stress model that includes pore pressure and three principal stress magnitudes and azimuths. OLCV calculates pore pressure and three principal stresses: vertical stress (S_v), minimum horizontal stress (S_{Hmin}), and maximum horizontal stress (S_{Hmax}). The workflow utilizes a pore pressure interpretation from SRT tests and employs a poroelastic stress model (described below) to estimate the horizontal principal stresses. Those stresses were utilized to assess the potential for shear and tensile failure in the matrix of the San Andres Formation.

Pore pressure (P_p) information was obtained from data collected in the Shoe Bar 1 and Shoe Bar 1AZ well.

The state of stress was modeled using the modified plane-strain poroelastic stress model, as shown in Equation 6.

$$\sigma_3 = \frac{\nu}{1-\nu}(\sigma_v - \alpha P_p) + \frac{\varepsilon_h E}{1-\nu^2} + \frac{\varepsilon_H \nu E}{1-\nu^2} + \alpha P_p \quad \text{Equation 6}$$

where:

σ_3 = least horizontal principal stress

ν = Poisson's ratio

σ_v = maximum principal stress

α = Biot's coefficient

P_p = pore pressure

ε_h = minimum tectonic strain

ε_H = maximum tectonic strain

E = Young's modulus

The geological interpretation of the failure mechanism in this area is transitional from normal faulting to strike-slip faulting (). The results of the interpretations indicate that the maximum principal horizontal stress (S_{Hmax}) is very similar in magnitude to the overburden stress (S_v). The overburden is calculated by integrating the density data over the interval from surface to the depth of interest at the bottom of the well. The overburden stress is represented by the black pressure profile in Figure 52.



Figure 52—Stress models used in Mohr-Coulomb analysis. Calibration used is formation pressure (blue dot), regional closure pressures (black squares), and closure pressure from mini-frac test (red square). Mohr-Coulomb analysis was conducted at 4,700 ft TVD.

The stress model was calibrated with regional fracture pressure measurements in offset wells, formation pressure interpretation from SRT, and interpreted closure pressure from a mini-frac test. A publicly available methodology for estimating the tectonic strain terms in the poroelastic stress equation (ϵ_h and ϵ_H) is used to calibrate the minimum and maximum principal horizontal stresses.

The stress model was plotted in Mohr circle space to assess the required increase in pore pressure to initiate shear or tensile failure on the rock matrix. A summary of stress magnitudes used in the Mohr circle analysis is presented in Table 7. The size of the Mohr circle is defined by the magnitudes of the minimum and maximum effective principal stresses. In this case, the minimum effective principal stress, σ_3 , is 1,100 psi. The maximum effective stress (σ_1) is the overburden (2,900 psi). In this stress state, the maximum shear stress (900 psi), observed as the shear stress read from the top of the Mohr circle, is small enough that the risk of shear failure is minimal given the measured unconfined compressive strength (UCS) of 6500 psi at 4700 ft TVD. As effective stress decreases, the matrix will enter negative effective stress before reaching shear failure so tensile failure is the primary potential failure mechanism. The pore pressure required to move the

effective stress state into tensile failure is near 1,100 psi. The anticipated maximum injection pressure of 750 psi is less than 90% of the 1,100-psi threshold to initiate tensile failure. Thus, CO₂ injection in the AoR is posing low risk of tensile failure in the San Andres Formation.

Table 7—Summary of stress magnitudes, injection pressures, and UCS magnitudes in Mohr-Coulomb analysis.

Depth	Injection Pressure (psi)	Overburden (psi)	Pob Gradient (psi/ft)	Pore Pressure (psi)	Pp Gradient (psi/ft)	Shmin (Closure) (psi)	Shmin Gradient (psi/ft)	SHmax (psi)	SHmax x Gradient (psi/ft)	UCS (psi)
4,700	750	5,000	1.06	2,185	0.50	3,300	0.70	4,975	1.05	6,500

The stress state of the reservoir determines the fracture initiation pressure which in turn limits the maximum operating pressure limit of the injector wells to maintain matrix flow. The fracture pressure of the target Injection Zone was estimated using Minifrac (or Diagnostic Fracture Injection Test) and Step Rate Tests performed in the Shoe Bar 1 and Shoe Bar 1AZ appraisal wells. The table below summarizes the results:

Table 8—Summary of San Andres Fracture Pressure Estimates by Mini-Frac and Step Rate Tests

Well	Sub-Zone	Tested Interval Top Perf-Bottom Perf (MD, ft)	Initial Reservoir Pressure (psi)	Type of Test	Estimated Fracture Gradient (psi-ft)
Shoe Bar 1	Lower San Andres (G1)	4827-4829	2200@4400ft	Mini-Frac	
Shoe Bar 1	Lower San Andres (G4, G1, Holt)	4421-5024	2200@4400ft	Step Rate Test	
Shoe Bar 1AZ	Lower San Andres (Holt)	5122-5132	2522@5088ft	Step Rate Test	
Shoe Bar 1AZ	Lower San Andres (G1)	4723-4733	2307@4596ft	Step Rate Test	

2.9.2 Mohr Coulomb Failure Analysis

The maximum shear stress is less than the minimum shear stress required to initiate failure, given a measured unconfined compressive strength (UCS) of 6,500 psi (Figure 53) at the depth of investigation. The most likely mechanism for formation fracture during injection is tensile failure.

Tensile failure takes place when the minimum effective stress reaches zero or goes negative. The limit is determined by the magnitude of the tensile strength of the formation so that failure takes place when the absolute magnitude of the negative effective stress exceeds the magnitude of the tensile strength of the matrix. In this project, tensile strength is assumed to be zero as a conservative engineering safety factor. Tensile failure occurs when the minimum principal stress reaches the tensile failure limit. The magnitude of that pressure increase can be read directly off the plot. It indicates that an increase in pore pressure of around 1,100 psi would have to occur to initiate tensile failure at this depth in the San Andres.

Figure 53 is an example from 4,700 ft TVD, but the same exercise was conducted throughout the depth interval of the San Andres Formation with little change in the final interpretation. In this case, injection pressure is expected to be less than 90% of the 1,100 psi required to initiate tensile failure.

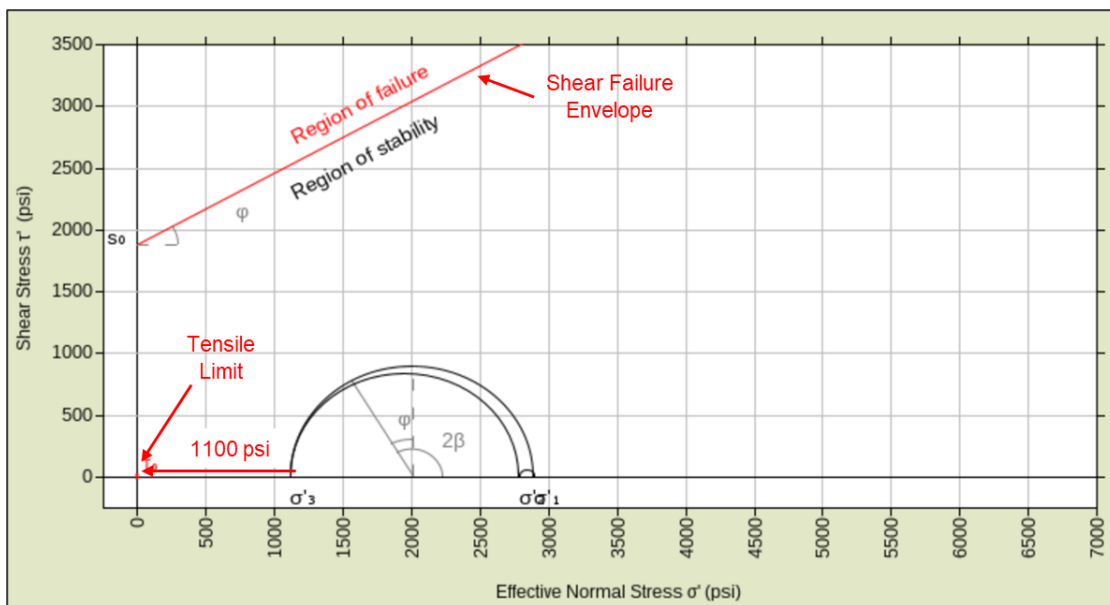

Figure 53—Mohr circle failure analysis of maximum stress state. Tensile failure risk is low given a reasonable estimate of tensile strength of the matrix.

The Mohr-Coulomb theoretical analysis was conducted using a stress model build from data acquired in the plugged heritage well, Shoe Bar Ranch 1 (API: 4213536163) using a formation pressure interpreted from SRT tests in the San Andres Formation. The well had the required density and sonic log data coverage over the interval of interest to build the geomechanical model. The geological interpretation is that the area is in a normal faulting/strike-slip transitional failure mode that is consistent with observations throughout the broader Permian Basin. The calibrated stress state indicates negligible risk of shear failure due to the generally low principal stress magnitudes and low maximum shear stress magnitude. The maximum shear stress in any orientation is less

than the minimum shear stress defined by the Mohr-Coulomb failure criterion. Tensile failure is the most likely mode of failure, and it would require approximately 1,100 psi increase to initiate failure in the matrix. Estimated operating pressures during CO₂ injection are expected to be less than 90% of the 1,100 psi required to initiate tensile failure, so risk of failure during CO₂ injection operations is low.

3.0 Computational Modeling Results

3.1 Predictions of System Behavior

Figure 54 and Figure 55 show the simulated well rates and bottom-hole pressures results, respectively. The group injection constraint of 1,058 Metric Tons per Day (MTPD) (384,800 MTPA) from January 2025 to December 2026 and 2,116 MTPD (769,600 MTPA) from January 2027 and January 2037 was honored. An injection bottomhole pressure (BHIP) for the BRP CCS1 well reported reaching a maximum of 2,640 psi. The BHIP of BRP CCS2 has variable value over the forecast period, reaching a maximum of 2,905 psi at end of December 2026 followed by increase in injection at the start 2027, reaching a maximum BHIP of 3,400 in July 2028, and decreasing to 3,150 psi at the end of the injection period. The BHIP of BRP CCS3 shows a maximum of 2,640 psi when the period starts in January 2027 until the end of injection in January 2037. The bottomhole injection pressures for all wells are below 90% fracture opening pressure (Table 9), and the brine producers help to relieve the pressure increase. Wells WW1, WW2, WW3, and WW4 produce at a group rate of 10,000 stb/d from January 2025 to December 2026 followed by a withdraw of 15,000 stb/d from January 2027 to January 2037 with a minimum flowing bottomhole pressure of 500 psi. Figure 56 describes the monthly volume and mass of CO₂ injection rate and the corresponding cumulative volumes respectively.

Figure 57 describes the CO₂ storage mass as a function of time in million metric tons (MMT). The total CO₂ stored is composed of structural and stratigraphically CO₂ (supercritical), dissolved in connate water CO₂, and residual trapped CO₂. In Figure 57, after injection ceases in January 2037, a portion of the stratigraphical and structural supercritical CO₂ is redistributed between the residual and solubility trapped CO₂ over the next 50 years. Structural and stratigraphic CO₂ is the main storage mechanism during the injection period. However, after injection finishes, residual trapped CO₂ quickly increases being an important long-term storage mechanism, representing about 50% of total stored CO₂. This process will continue over time and increase the security of permanent storage of the injected CO₂.

A total of 8.47 MMT is estimated to be stored during the 12-year injection period. The resulting maximum extents of the CO₂ plume and the pressure front are discussed in Section 4.0 AoR Delineation. The movement of the CO₂ plume and pressure front with time are shown in Section 5.3 of the Area of Review and Corrective Action Plan and in the Post-Injection Site Care and Post-Injection Site Closure Plan of this permit application.

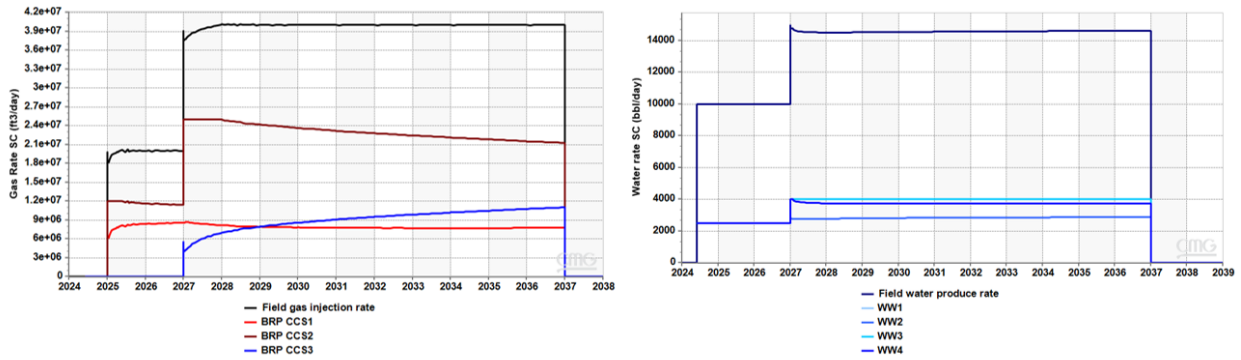

Figure 54—Left: Simulated Project and well CO₂ injection rates. Right: Project and well water production rates.

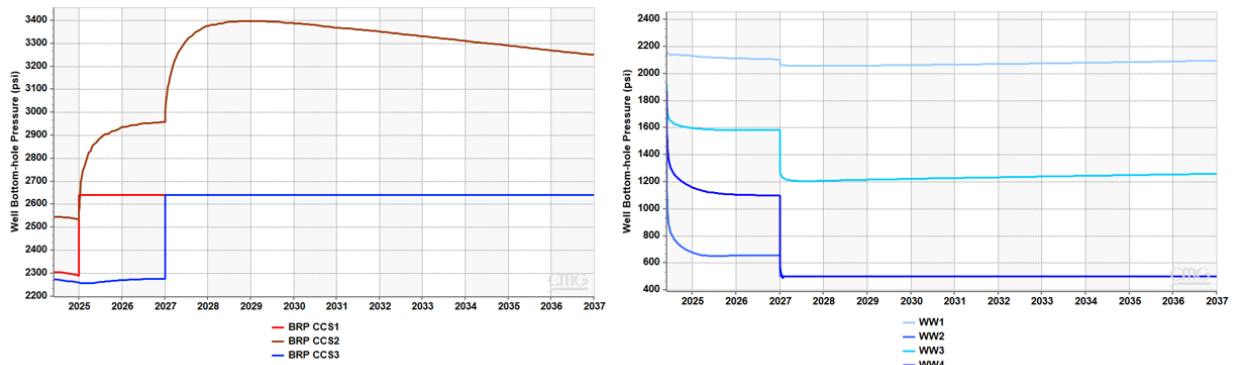

Figure 55—Simulated bottomhole pressures of CO₂ injectors and water producers.

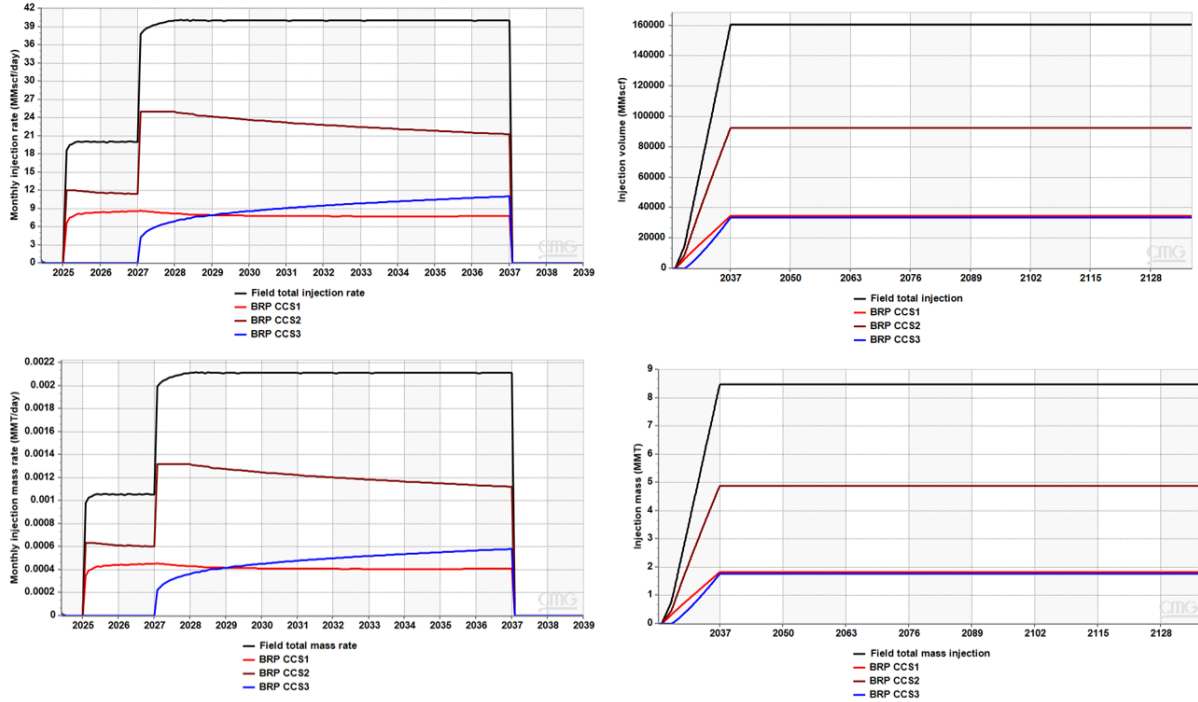

Figure 56—Monthly volume rate, mass rate, cumulative volume, and cumulative mass of CO₂ injected.

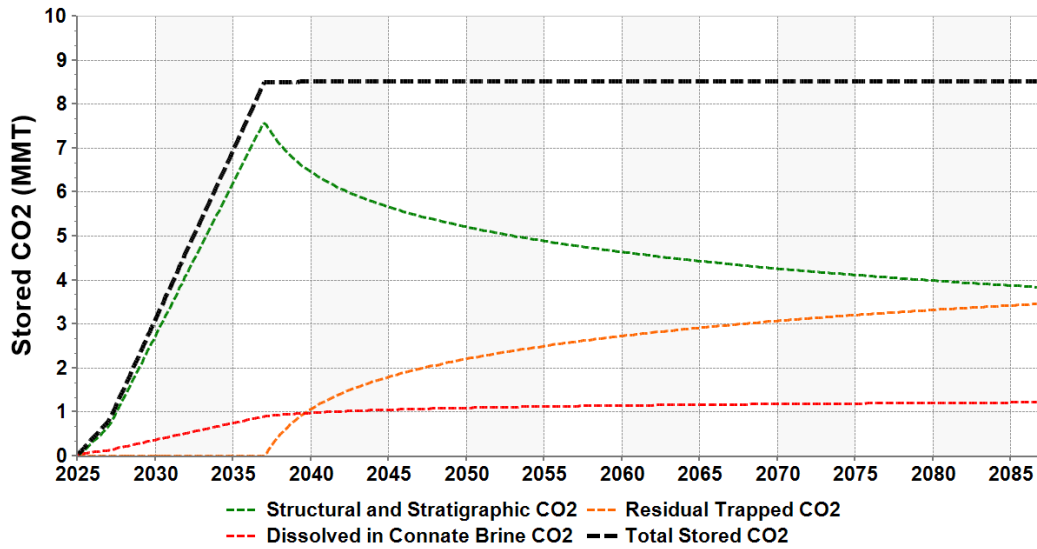

Figure 57—Forecasted CO₂ storage in mass by mechanisms (structural and stratigraphic, dissolved in connate brine, and residual) as a function of time.

3.2 Model Calibration and Validation

3.2.1 Model sensitivities

To test the field response to CO₂ injection, sensitivities of the results to subsurface uncertainties were explored. These uncertainties include horizontal permeability multiplier (Kh multi), porosity multiplier (Por multi), critical gas saturation (Sgcrit), gas endpoint relative permeability endpoint (Krg), Land trapping coefficient (Land C), and the aquifer boundary condition (with 0 being no flow and 1 being a leaky side boundary). Porosity and permeability multipliers are applied to the whole simulation model. The leaky side boundary was simulated by assigning an analytical Carter-Tracy aquifer with infinite extent. The relative permeability values were based on maximum and minimum values reported from laboratory experiments for the Injection Zone.

Table 9 summarizes the possible ranges of these subsurface inputs and the corresponding base case inputs. In Table 9, D indicates a discrete distribution (maximum and minimum values tested).

Table 9—Uncertainty Ranges of Reservoir Parameters

Parameter	Distribution	Base Case Input
Horizontal permeability multiplier (Kh multi)		
Porosity multiplier (Por multi)		
Critical gas saturation (Sgcrit)		
Gas endpoint relative permeability (Krg)		
Land coefficient (Land C)		
Aquifer boundary		

The selected response variables are summarized below:

- Field gas injected total (FGIT) in million metric tons (MMT)
- Field average reservoir pressure (FPR_AOI) in psi
- Dissolved CO₂ total in MMT
- Structural and stratigraphic (supercritical) CO₂ total in MMT
- Residual trapped CO₂ total in MMT

Figure 58 shows sensitivities of the specific simulation outputs mentioned above to the parameter ranges at the end of injection period (January 2037) and at the end of sequestration period (December 2086). The response to more favorable variable values for sequestration in the uncertainty analysis do not impact on FGIT since the field rate is limited to a group injection constraint (384,800 MMTPA, until December 2026 and 769,000 MMTPA, until January 2037). The injection is most sensitive to the lower bound horizontal permeability multiplier (KMULT = 0.8) but with only 9% reduction in total volume. The average pressure change in the AoI is slightly impacted by the aquifer boundary condition of ~10 psi because the pressure change is dominated

by the well rates rather than the far-field boundary conditions. The relative permeability parameters have a minimal impact on the overall injection performance. However, critical gas saturation affects the trapped CO₂ storage mechanism, as shown in the last plot of Figure 59. A higher critical gas saturation results in a larger volume of CO₂ trapped in the pores. Both structural/stratigraphic and dissolved CO₂ volumes are sensitive to the horizontal permeability multiplier. However, it is very unlikely to have an overall reduction in the field permeability by 20% based on the data collected from Shoe Bar 1 and Shoe Bar 1AZ and the injectivity tests. In addition, permeability close to the well bore can be enhanced by stimulation to mitigate any lower permeability found in the injection wells.

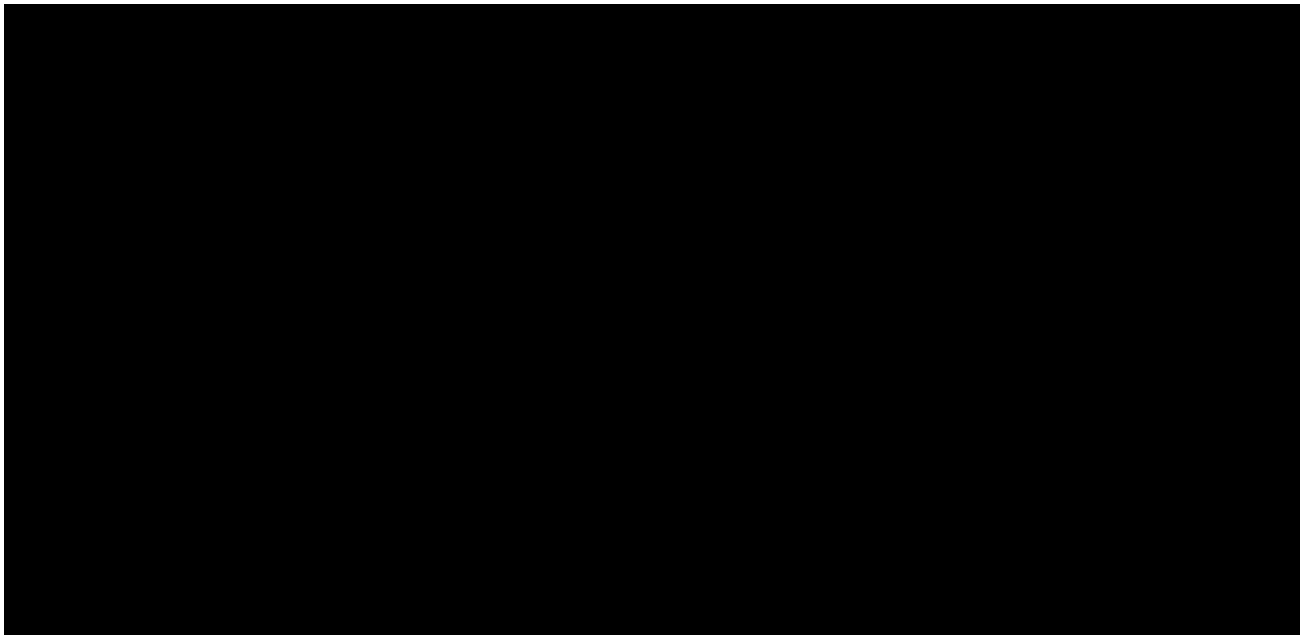

Figure 58—Tornado charts showing the sensitivity of simulation outputs to the input parameter ranges at the end of injection and at the end of post-injection periods. Blue and orange bars represent the lower and upper bounds, respectively.

The effect of the horizontal permeability multiplier, porosity multiplier and aquifer condition in reservoir pressure over time is shown in the left subplot in Figure 59. It is important to notice that reservoir pressure stabilizes after the injection period and the effect of the flow boundary condition is negligible. Figure 59 shows in the right subplot the effect of the relative permeability parameters in the amount of trapped CO₂. The trapping mechanism continues in the post-injection period in a continued process over time and increases the security of permanent storage of the injected CO₂.

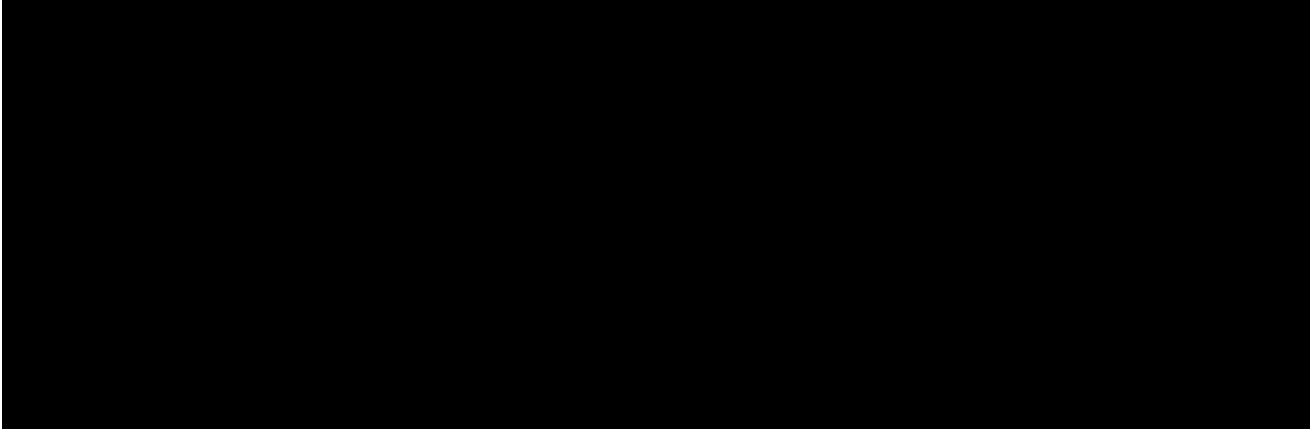

Figure 59—Influence of horizontal permeability multiplier, porosity multiplier and aquifer condition in reservoir pressure (left) and the relative permeability parameters (Krg, Sgcrit and Land C) in the amount of residual trapped CO₂.

3.2.2 Geochemical Modeling

3.2.2.1 Background and literature review

The main reactive transport phenomenon of interest in carbonate reservoir CO₂ storage projects is mineral dissolution by weak carbonic. The dissolution of the mineral can alter the porosity and the permeability of the reservoir rock, affecting sequestration storage capacity, well injectivity, and integrity of confining zones. For the BRP Project, dolomite is the dominant mineral in the Injection Zone and anhydrite is the dominate mineral in the Upper Confining Zones. Oxy's operational experience in San Andres reservoirs has shown that the effect of reactive transport on reservoir performance is insignificant.

- A pilot study conducted at the Denver Unit (Mathis and Sears, 1984) showed that no significant changes in porosity and pore structure were observed after more than two years of CO₂ and water injection. The study concluded that dolomite dissolution was insignificant and anhydrite loss had a minor effect on porosity.
- Mohamed et al (2011) conducted laboratory study performing CO₂ flooding on 20 Silurian dolomite cores (97.5% molar analogous to San Andres) at different conditions (temperature from 70 to 200°F, injection rates from 2 to 10 cm³/min and, five different flood designs of water alternating gas [WAG]). The authors concluded that CO₂ had a minor effect on core porosity and permeability. They observed slight dolomite dissolution and possible calcium carbonate precipitation.
- Hangx et al. (2009) conducted a laboratory study to evaluate the integrity of an anhydrite rock with 10 to 33 wt.% dolomite in contact with CO₂. These samples are lithologically analogous to the BRP Project Upper Confining Zone, with 0.1 - 0.3% porosity and 1×10^{-4}

mD. Compression experiments were executed to understand rock mechanical integrity with fully CO₂-saturated pore fluid, similar to the conditions expected during injection. The authors concluded that any fractures created during injection would be healed.

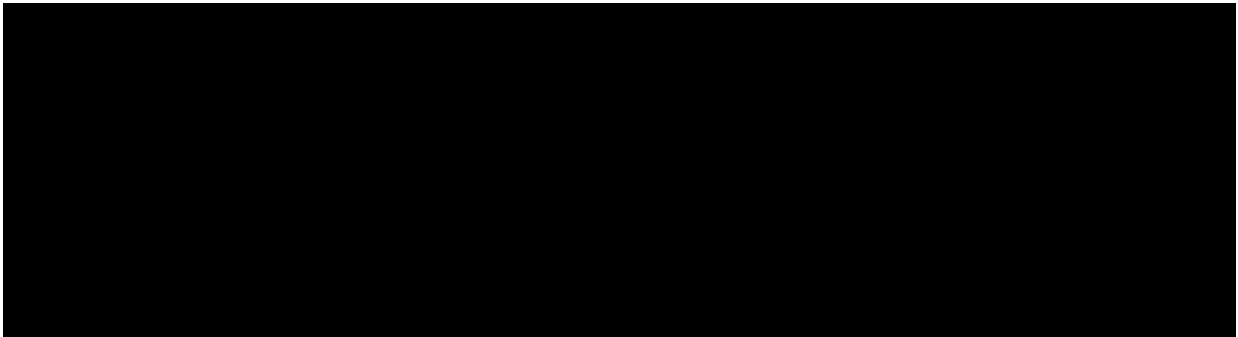

In addition to literature and Oxy's experience in CO₂ injection at San Andres Formation, OLCV conducted geochemical equilibrium and reactive-transport simulations modeling to evaluate site specific data acquired from the Shoe Bar 1 stratigraphic test well.

3.2.2.2 Geochemical Equilibrium Simulations

Geochemical equilibrium modeling was conducted using PHREEQC Simulator Version 3 (Parkhurst and Appelo, 2013), a program developed by the USGS that includes a robust thermodynamic database for aqueous, mineral, and gaseous interactions (Krupka et al., 2010). PHREEQC includes the Peng-Robinson equation of state to improve the solubility calculation of gas at high pressures, which is important to consider when studying CO₂ sequestration in saline aquifers.

The objective of this work is to identify primary chemical reactions (solid and aqueous phase) to be included into the reactive-transport simulations and provide initial assessment of the CO₂ compatibility with rocks and fluids in the Injection and Upper Confining Zones. The modeling includes brines speciation, geochemical baseline prior injection, and CO₂ interaction with reservoir brine and minerals.

Table 10 shows the brine composition for three samples collected at 4,603, 4,770 and 5,129 ft used in geochemical simulations (See Appendix A: Stratigraphic Well Summary for full geochemical results). Other ions were not considered in modeling because their concentration is negligible or below detection limits. Trace metals (i.e., arsenic, mercury, and lead) have insignificant concentration values and were not tracked during modeling. Table 11 summarizes the rock mineralogy used during geochemical equilibrium runs for the Injection Zone. The normalized values were obtained from the average of the five closest depth samples reported in the XRD data in (See Appendix A: Stratigraphic Well Summary for XRD results). The Upper Confining Zone was modeled as 90% anhydrite and 10% dolomite weight percent, based on lithology results from log data.

Table 10—Water composition and brine properties for Samples 1, 2 and 3 from Shoe Bar 1AZ.

A large black rectangular redaction box covering the entire content of Table 10.

Table 11—Rock mineralogy retrieved from average XRD data for the five closest core samples.

A large black rectangular redaction box covering the entire content of Table 11.

Although some chemical reactions are known to be time dependent, the equilibrium assumption was selected at this stage, because it is the most conservative approach. In this method, minerals can dissolve or precipitate instantaneously and achieve final stage of interaction with other solid phase and aqueous species. Thus, this process can simulate the long-term exposure and mimic permanent CO₂ storage. For reactive-transport simulations, kinetics approach is assumed, and further details are presented in Section 3.2.2.3.

Geochemical simulations were performed to equilibrate each sample with their respective reservoir mineralogy and in-situ CO₂ concentration to simulate conditions prior to injection period and

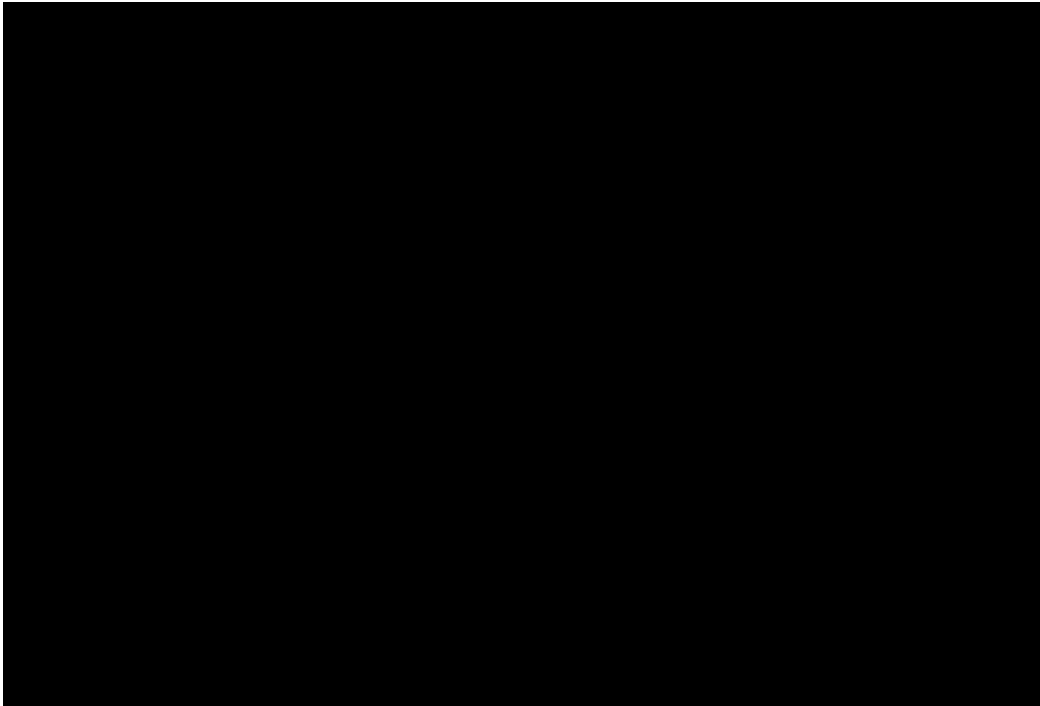
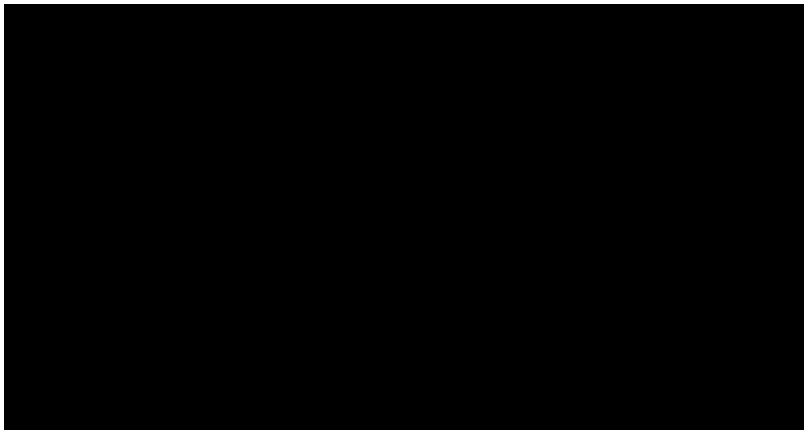
establish the baseline condition. Table 12 and 13 show the results for the Injection and Upper Confining Zones, respectively. For equilibrium simulations, a rock with porosity equal to 10% is assumed. Initial CO₂ concentration in the reservoir was retrieved using flashed gas composition and the fugacity was calculated using PHREEQC based on Peng-Robinson model at reservoir pressure and temperature. [REDACTED]

The PHREEQC database file was selected as the thermodynamic data and activity coefficient model for equilibrium and reactive-transport simulations. Although Pitzer virial model is known to be more suitable for brines with high ionic strength (above 1.0 M) at certain conditions, the extended Debye-Hückel equation is determined to be suitable for the brines analyzed for the BPR Project. Besides the ion-size parameters, the extended terms based on ionic strength have been fit for main ions in chloride dominated waters (Truesdell and Jones, 1974) such as calcium, magnesium, sulfate, potassium, and carbonate species. In addition, the Pitzer approach has limited parametrization for sulfate complexes (i.e., NaSO₄⁻, CaSO₄⁰, MgSO₄⁰, KSO₄⁻, BaSO₄⁰), similarly observed for iron and aluminum species (Krupka et al. 2010). These aqueous complexes are very important for brines in equilibrium with sulfate-type minerals (CaSO_{4(s)}) because they modify the sulfate activity, having critical impact on gypsum and anhydrite solubility product (Appelo and Postma, 2005, page 129).

Several mineral phases were included in the simulation even though they are not present in measured XRD data (i.e., pyrite, hematite, chlorite, illite, kaolinite, barite, strontianite, celestite, and magnesite) to evaluate their precipitation tendency. Since the reservoir is assumed to be initially in equilibrium, saturation indexes were slightly adjusted (from database equilibrium constant value, K_{sp}) to avoid large mineral dissolution or precipitation and honor measured XRD data. Positive and negative saturation index numbers (ΔSI) indicate changes to more supersaturated or undersaturated condition in relation to a mineral, respectively.

Pyrite, hematite, chlorite, illite, kaolinite, barite, strontianite, celestite, and magnesite were considered stable phases without precipitation tendency. As expected, all brine samples are in very close equilibrium condition with their respective minerals and initial CO₂ in the reservoir. Sample 2 is the one that requires the largest changes in saturation index for anhydrite and gypsum. Quartz and k-mica are the most stable phases. Calculated pH from simulations is slightly smaller in comparison to laboratory measured ones. This behavior is due to the degassing effect from depressurization when the samples are open to atmospheric conditions for measurement. Even with the quickest analysis in the laboratory after chamber being open, CO₂ is quickly released to atmosphere, decreasing its amount dissolved in water, shifting the equilibria to more a basic condition (Appelo and Postma, 2005, page 14).

Table 12—Adjusted saturation indexes and pH for Sample 1, 2, and 3 at the Injection Zone prior to CO₂ injection.

A large black rectangular redaction box covering the entire content of Table 12.

Table 13—Adjusted saturation indexes and pH for Sample 1, 2, and 3 at the Upper Confining Zone prior to CO₂ injection.

A large black rectangular redaction box covering the entire content of Table 13.

The same shift in saturation index found in previous simulations were used to equilibrate the brines and minerals with fully saturated CO₂ gas to represent the injection period. [REDACTED] [REDACTED] [REDACTED] at reservoir temperature and pressure. Table 14 shows the mineral stability tendency after equilibration for each sample in the Injection and Upper Confining Zone. Delta minerals (Δ Mineral) represent the qualitative analysis of the solid to dissolve, precipitate or be stable based on the mineral mass reduction, increase or maintenance after equilibration with CO₂, respectively.

Precipitation was not observed (or negligible) for pyrite, hematite, chlorite, illite, kaolinite, barite, strontianite, celestite, and magnesite. Quartz and k-mica are the most stable phases that are originally present in the reservoir. For the Injection Zone, simulation results show dolomite and calcite dissolution as larger amount of CO₂ dissolved in water shifts the equilibria to more acidic environment. In addition, a substitution process of gypsum into anhydrite occurs for sample 1 and 2. This is because anhydrite is the most stable phase for the reservoir conditions. However, the

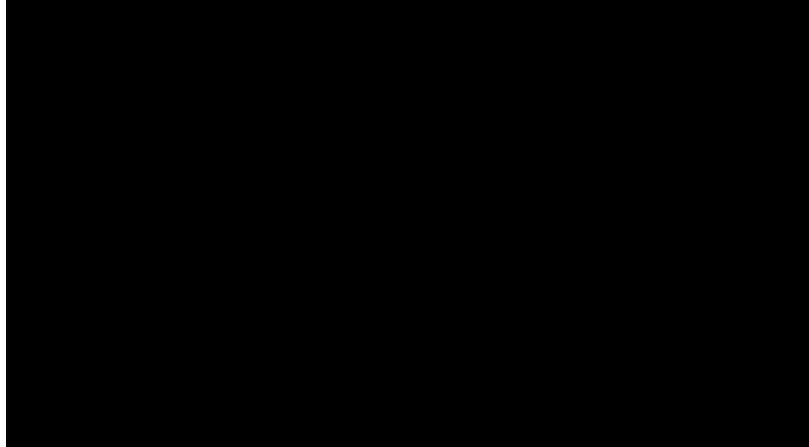
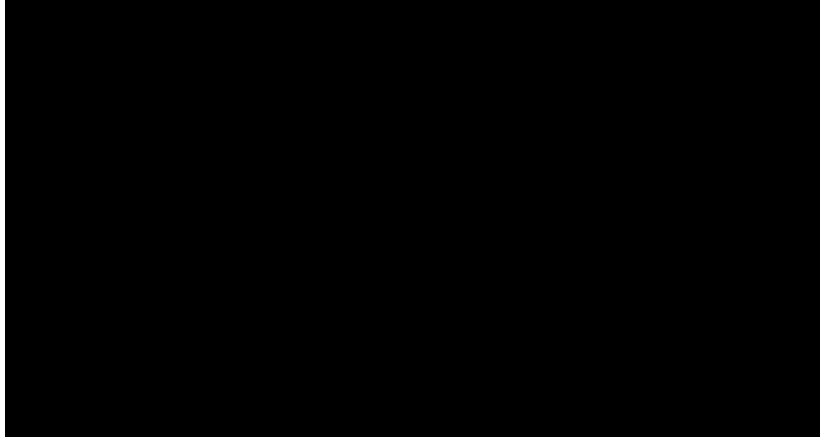
dynamics in the reservoir during injection is more complicated as reactions are time dependent and gypsum is expected to reprecipitate much faster than anhydrite when there is an excess of calcium and sulfate. The Upper Confining Zone shows negligible reactivity as anhydrite does not dissolve. Some of the CaSO₄ might be transported from the Injection Zone to the interface of the Upper Confining Zone, increasing anhydrite or gypsum tendency to precipitate, and providing a healing effect to microfracture that might have been formed (i.e., mechanical deformation), as proposed by Hangx et al (2009).

Table 14—Mineral stability tendency and pH for Sample 1, 2, and 3 in equilibrium with fully saturated CO₂.

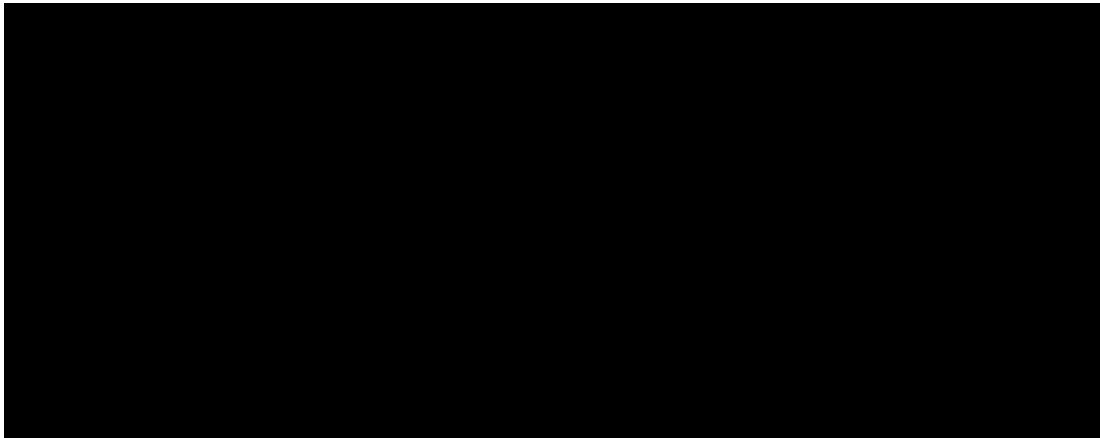

Thus, the most important mineral reactions with CO₂ identified for the injection are the solubility equilibria for dolomite, calcite, gypsum, and anhydrite minerals. The Upper Confining Zone is shown to be chemically compatible with CO₂ at reservoir pressure and temperature, thus its composition is not considered in the following simulations.

3.2.2.2 Reactive-Transport Simulations

The reactive-transport simulations were conducted using GEM. The objective of this section is to evaluate geochemical impact on reservoir storage capacity, possible injectivity modification, and mechanisms. The same activity model is used (extended Debye-Hückel equation) to be consistent with geochemical equilibrium simulations. Dolomite, calcite, gypsum, and anhydrite are the minerals considered during the dynamic simulations.

Figure 60 illustrates a cross-section for different mineralogy regions based on the Shoe Bar 1AZ lithology from well log (Figure 39). Region A represents G1 and G4 sub-zone, region B represents the limestone found at the top of the Holt sub-zone, and C represents the lower of the Holt sub-zone. Table 15 shows the mineralogy volume fraction based on the normalized average XRD data for each region. Trace mineral amount (1×10^{-4} volume fraction) is given as input to make the simulation more stable. In addition, small mineral content is expected to be naturally occurring in the reservoir.

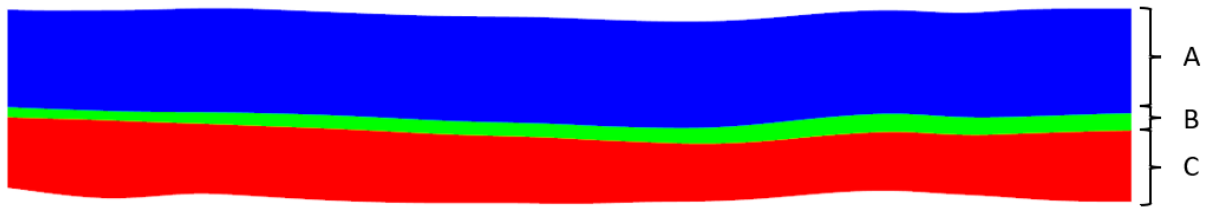

Figure 60—Cross-section schematic of the simulation model showing the different lithology regions (A, B, and C) based on lithology logs.

Table 15—Mineral volume fraction used to initialize the reactive-transport simulation model per lithology region.

The table content is completely redacted with a solid black box.

Dolomite, calcite, and anhydrite solubility reactions were simulated using the kinetics approach based on the transition state theory (TST). Gypsum solubility reaction is simulated using the equilibrium approach because its reaction is assumed to be much faster than the fluid residence time in the reservoir and with the reaction time compared to other minerals (Appelo and Postma, 2005, page 119). Reactive surface areas, activation energies, TST reaction rate constants, and equilibrium constants are retrieved from the literature (Palandri and Kharaka, 2004, Krupka et al. 2010, Jia et al. 2021, and Zhang et al. 2019).

The effect of mineral dissolution and precipitation on porosity is also included to evaluate its impact on reservoir storage. The model is based on the simple correlation that the amount of mineral change will directly impact the solid volume using the respective mineral mass, mineral molar weight, and mineral density to calculate the new void volume (porosity) over time. In addition, the effect of porosity changes in rock permeability is included to evaluate the effect of possible changes in well injectivity. Simulations use the modified Kozeny-Carman model (Equation 7), where the porosity exponent r is assumed to be equal to 3.0.

$$\frac{k_n}{k_k} = \left(\frac{\phi_n}{\phi_k}\right)^r \left(\frac{1-\phi_k}{1-\phi_n}\right)^2 \quad \text{Equation 7}$$

where k , ϕ , and r represent permeability, porosity, and t porosity exponent, respectively. The subscripts n and k represent the properties changes in previous and current timesteps, respectively.

Region A and B were initialized using Sample 1 and Region C initialized using Sample 3 based on their depth. In total, 22 aqueous species were initialized in reservoir connate water and allowed to be transported in the reactive-transport simulations. The aqueous species modeled are H^+ , Ca^{2+} , Mg^{2+} , Na^+ , SO_4^{2-} , Cl^- , HCO_3^- , $CaOH^+$, $CaSO_4^0$, OH^- , $MgOH^+$, $MgSO_4^0$, $NaHCO_3^0$, $NaSO_4^-$, HSO_4^- , $CaCO_3^0$, $CaHCO_3^+$, $MgCO_3^0$, $MgHCO_3^+$, $NaCO_3^-$, CO_3^{2-} , and $NaOH^0$. The selection of the aqueous complexes was based on the simulation results from geochemical equilibrium runs (PHREEQC) with minerals and CO_2 . Aqueous species that were not originally in the complete water analysis were assumed to have trace concentration. The reservoir is allowed to equilibrate prior to simulation start.

Figure 61 shows map view of the layer with largest change in porosity (Holt sub-zone) and N-S cross-sections for BRP CCS1, CCS2, and CCS3 at the end of the injection period. Negative and positive values represent increase and decrease in porosity, respectively. Porosity slightly increased for regions A and C where the injectors will be perforated. Since region B has a very low permeability and small fluid mobility, no significant changes are observed. The increase in porosity is due to carbonate dissolution (dolomite and calcite) because lower pH after injection, as shown in Figure 62. Note that the pH values (initial and during injection) are in very close agreement with the values simulated using PHREEQC. For BRP CCS3, minor gypsum and anhydrite precipitation are illustrated in region B (limestone), showing the healing process as discussed before. Overall, the porosity increase is insignificant.

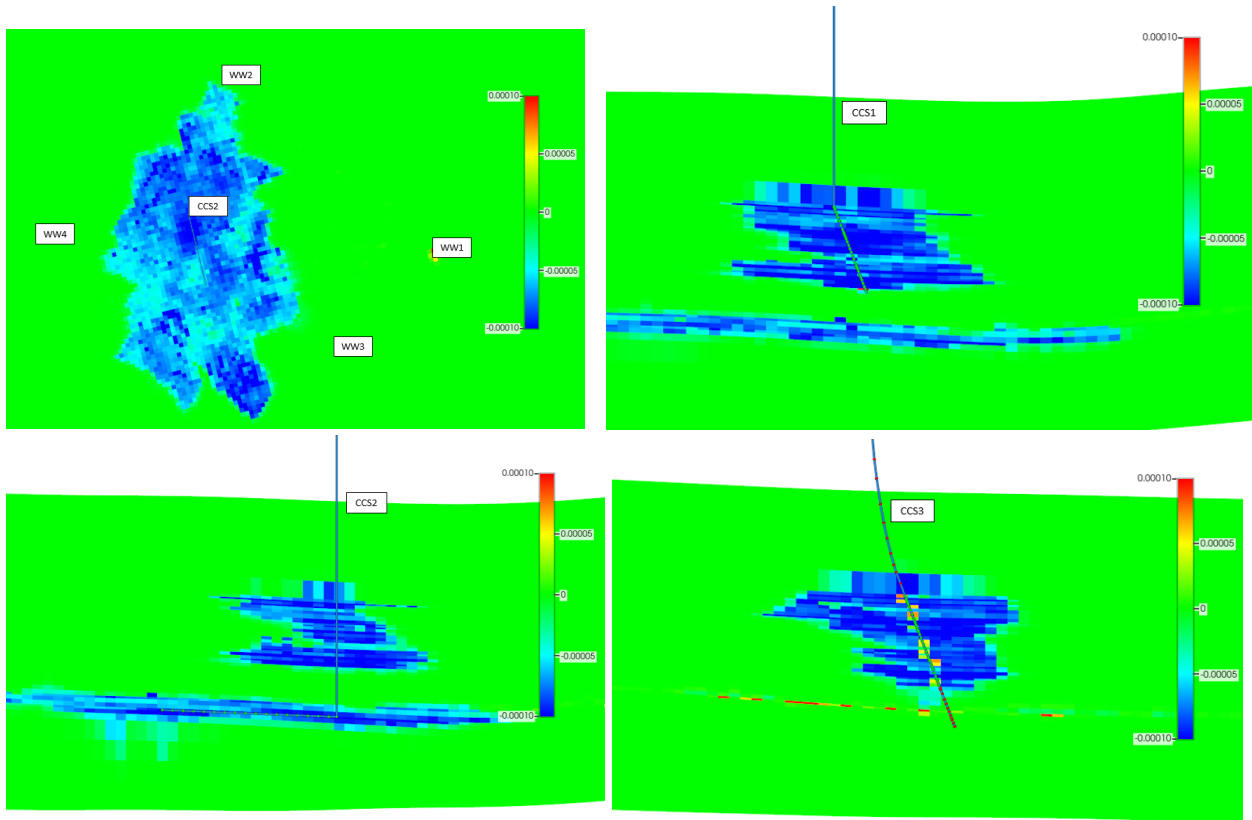

Figure 61—Porosity change map view of the layer with the largest CO₂ extension (top left subfigure) and N-S cross-section for BRP CCS1 (top right subfigure), CCS2 (bottom left subfigure), and CCS3 (bottom right subfigure) in January 2037.

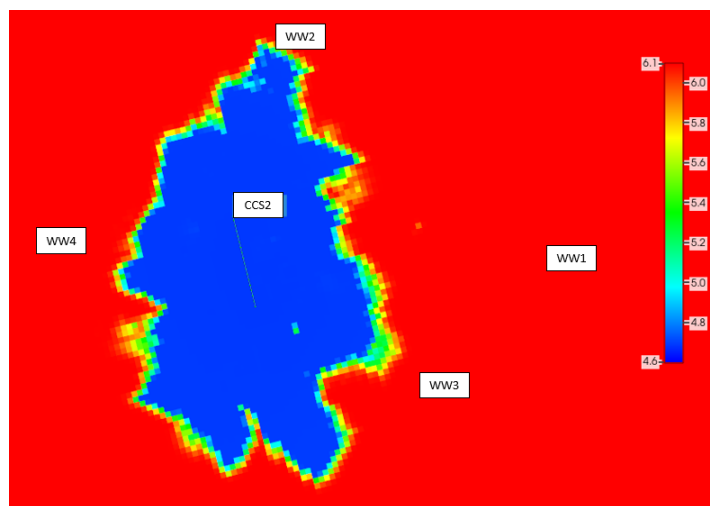

Figure 62—pH map view of the layer with the largest CO₂ extension in January 2037.

Figure 63 shows the reservoir mineral volume change for dolomite, calcite, anhydrite, gypsum, and total (Field) over time. Dolomite and calcite dissolve while anhydrite and gypsum precipitate. Most of the total increase in mineral volume because of solid change occurs during the injection period. The dissolution rate decreases in the following years. Anhydrite and gypsum precipitate due to release of calcium from the carbonate minerals and excess of sulfate originally in the reservoir. Figure 64 shows the increase of calcium ions and decrease of sulfate ions in relation to their initial value. Considering the total pore volume only where CO₂ contacted (2.98 billion ft³) and the maximum volume change in the reservoir due to mineral dissolution/precipitation (1.36 million ft³ in 2087), the change in pore volume is about 0.046%. Thus, the results reassure that the changes in reservoir storage volume due to injection is negligible.

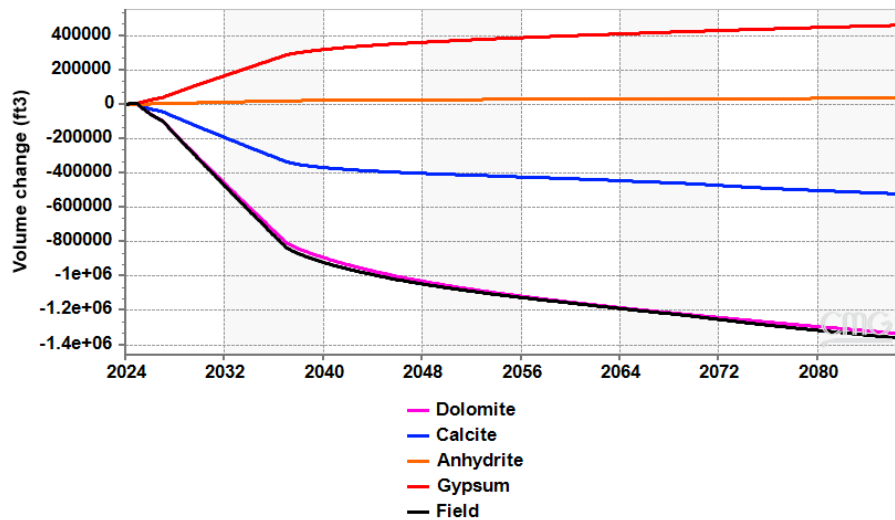

Figure 63—Volume change (ft³) over time in the reservoir for dolomite, calcite, anhydrite, and gypsum and total (Field) due to mineral dissolution or precipitation.

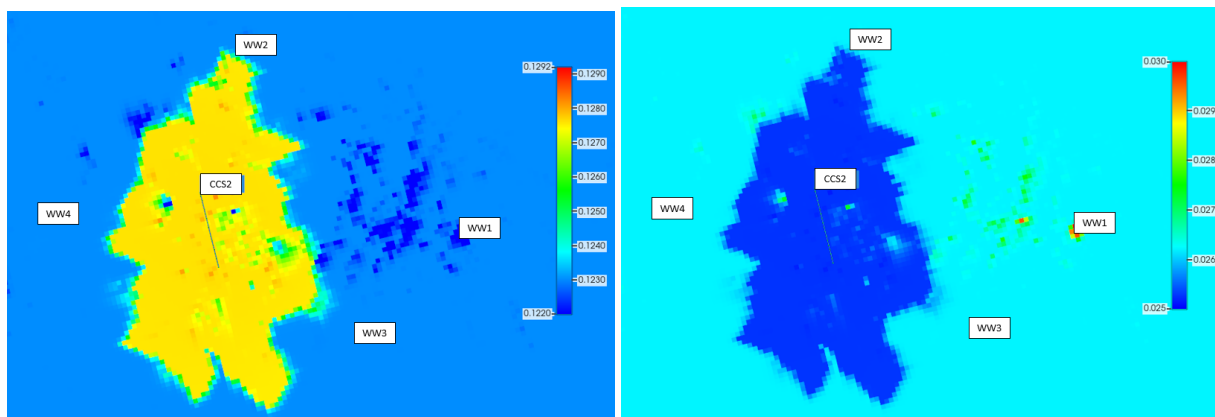

Figure 64—Map view of calcium (left) and sulfate (right) ions molality for the layer with the largest CO₂ extension in January 2037.

Figure 65 shows the injection and production comparison for the simulations with and without geochemistry capability turned one, including gas injection rate, water production rate, injectors bottom-hole pressure, and producers bottom-hole pressure over time. The differences in injection and production are negligible because the permeability is directly related to porosity modeled by the Kozeny-Carman equation (Equation 7). Thus, well injectivity is considered unchanged due mineral dissolution and precipitation.

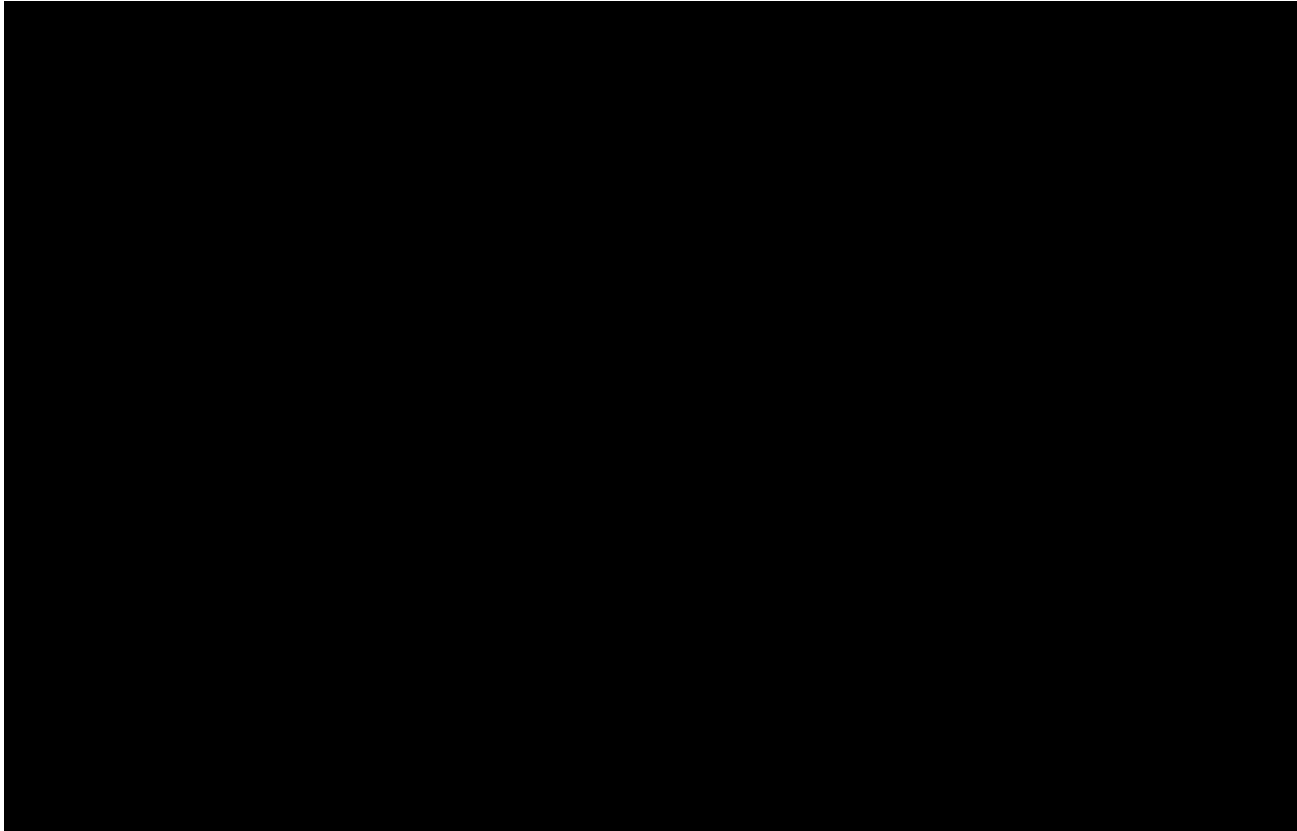

Figure 65—Injection and production comparison for the simulations with and without geochemistry capability turned one, including gas injection rate, water production rate, injectors bottom-hole pressure, and producers bottom-hole pressure over time.

Figure 66 shows the CO₂ storage mechanisms (structural and stratigraphic, dissolved in connate brine, and residual) comparison over time with and without geochemistry capability turned on. Results indicate that the main stored mechanisms remain unchanged during reactive-transport simulations in comparison to conventional simulation. Figure 67 shows the mineral and aqueous ion CO₂ for the reactive-transport simulations (with geochemistry). The mineral storage is negative mainly due to dolomite dissolution that releases two mols of carbonate ion that is solubilized into aqueous ion. The aqueous Ion CO₂ stored has same values if the mineral CO₂ is multiplied by [REDACTED]

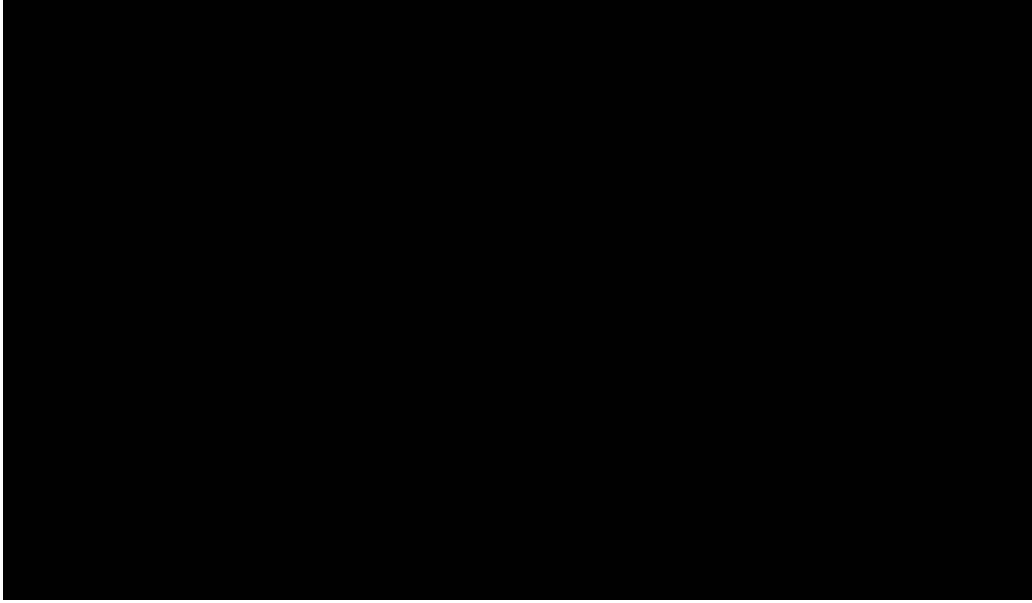

Figure 66—Structural and stratigraphic, dissolved, residual trapping, and total CO₂ storage for simulations with and without geochemistry capability turned on.

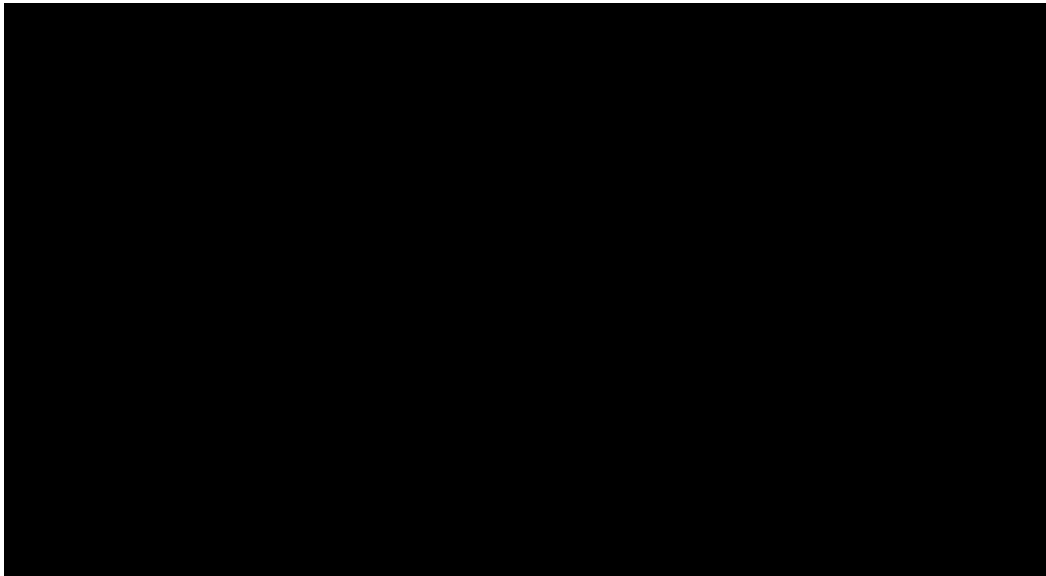

Figure 67—Mineral and aqueous ions CO₂ storage for simulation with geochemistry capability turned on.

4.0 AoR Delineation

4.1 Critical Pressure Calculations

To delineate the critical pressure front, one must determine the minimum pressure differential that can reverse flow direction between the lowermost USDW and the Injection Zone, thereby causing fluid flow from the Injection Zone into the USDW formation matrix in acceptable volume over the sequestration period. In other words, it is necessary to establish the critical pressure threshold

at which the increase in pore pressure is high enough to overcome the hydraulic head of the fluid in a hypothetical wellbore and enter the USDW.

OLCV attempted to calculate the critical pressure front, p_c , using Method 1 provided in the EPA May 2013 Program Class VI Well Area of Review and Corrective Action Evaluation Guidance (EPA 2013). This method estimates a critical pressure threshold that would displace fluid initially present in a hypothetical borehole into the lowermost USDW and takes in consideration that the reservoir is overpressured at the start of the injection, which is the case for the proposed AoI.

As noted by Thornhill et al. (1982), the critical pressure front may be calculated using the following equation:

$$p_c = p_u + \rho_i g \cdot (z_u - z_i) \quad \text{Equation 8}$$

where, p_c is the critical pressure threshold, p_u is the initial fluid pressure in the USDW, ρ_i is the Injection Zone fluid density, g is the acceleration due to gravity, z_u is the representative elevation of the lowermost USDW, and z_i is the representative elevation of the Injection Zone.

Similarly, the increase in pressure that may be sustained in the Injection Zone (Δp_{if}) can be calculated using the following equation:

$$\Delta p_{if} = p_u + \rho_i g \cdot (z_u - z_i) - p_i \quad \text{Equation 9}$$

where p_i is the initial pressure in the Injection Zone.

As provided by Nicot et al. (2009) and Bandilla et al. (2012), one can calculate the threshold pressure increase (Δp_c) assuming hydrostatic conditions and the uniform density approach by the equation:

$$\Delta p_c = \frac{1}{2} \rho_i \xi \cdot (z_u - z_i)^2 \quad \text{Equation 10}$$

and

$$\xi = \frac{(\rho_i - \rho_u)}{(z_u - z_i)} \quad \text{Equation 7}$$

where ρ_u is the fluid density of the USDW.

As stated for the Method 1, if the value of Δp_c given in Equation 10 is greater than absolute value of Δp_{if} given in Equation 9, then the difference in magnitude between these values can be used to estimate the allowable pressure. Assuming a freshwater of 62.4 lb/ft³ for the USDW and applying the calculation at the top of the Lower San Andres Formation, one can observe that the criteria does not hold ($\Delta p_c = 94.1$ psi, $\Delta p_{if} = -145.3$ psi, then $\Delta p_c < |\Delta p_{if}|$). Thus, OLCV decided to define the impact of additional pressure increase from injection using combined Methods 2 (multiphase

numerical model designed to model leakage through a single well bore, or multiple well bores in the formation, from UIC Program Class VI Well Area of Review Evaluation and Corrective Action Guidance) and Method 3 (numerical ground water modeling conducted for the USDW to estimate how additional fluid leakage caused by the injection project is diluted within the USDW and attenuated, from UIC Program Class VI Well Area of Review Evaluation and Corrective Action Guidance).

The method proposed by Birkholzer et al. (2011) and Oldenburg et al. (2014), where reservoir simulation (as multiphase numerical tool) can be used to model the leakage through single well, was selected. The method consists of providing the USDW aquifer as a separate initialization region in the simulation model. Then, a permeable conduit connects the injection and USDW regions to mimic flow in a well to the USDW (Figure 68). This simulates a well that have been cemented during abandon which is the case for the legacy wells found inside the AoI. The well is assumed to be cemented from bottom of the USDW to bottom of the Injection Zone and fluid can flow inside the well from the matrix from any direction.

The approximate distance between the USDW and the top of Lower San Andres Formation in the AoI is ~4,300 ft. The USDW is assumed to have initial average pressure of 300 psi (with average thickness of 286 ft), mean porosity of 20% (values range from a minimum of 17% to a maximum of 23%), and mean permeability of 483 mD (values range from minimum of 93 mD to a maximum of 962 mD). These permeability values are based on hydraulic conductivity reported for the Dockum aquifer (Bradley and Kalaswad, 2001; Mace et al., 2006; George et al., 2011) and in agreement with average porosity and permeability values for unconsolidated sands (Freeze and Cherry, 1979). The Injection Zone and USDW water salinity was assumed to be constant equal to 130,000 and 500 ppm, respectively. The cement permeability is assumed to have 26.3 mD in all directions as the largest value found by Kutchko et al. (2008) during laboratory experiments using Class H cement exposed to supercritical CO₂ and CO₂-saturated brine for prolonged time periods. The Upper Confining Zone surrounding the well is assumed to have permeability about 1×10^{-4} mD.

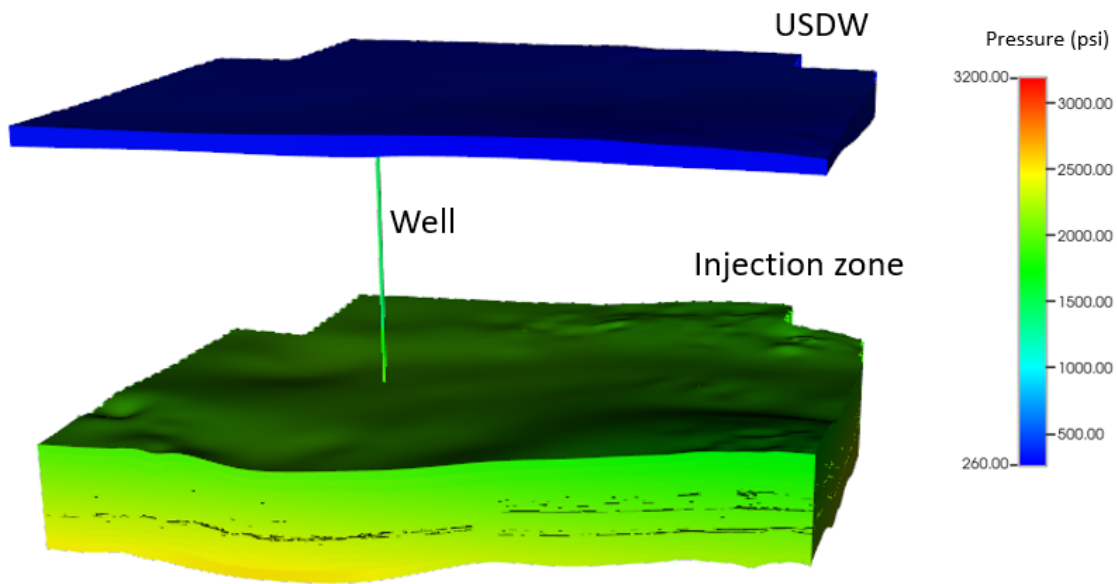

Figure 68—Schematic showing the USDW (top), Injection Zone (bottom) and the well connecting both regions. Figure with scale 5:1 in z direction. Confining Zones are not shown.

In the proposed AoI, the Santa Rosa member of the Dockum group aquifer is the lowermost USDW (Figure 68). From Equation 8, the critical pressure should be the lowest at the top of the Injection Zone, because this where the distance between the Injection Zone and the lowermost USDW will be at a minimum. However, the BRP CCS2 has the highest injection pressure and will be perforated in the Holt sub-zone. Thus, for this study, the pressure plume is evaluated for both at top of the Lower San Andres Formation (G1 sub-zone) and the top of the Holt sub-zone (Figure 69).

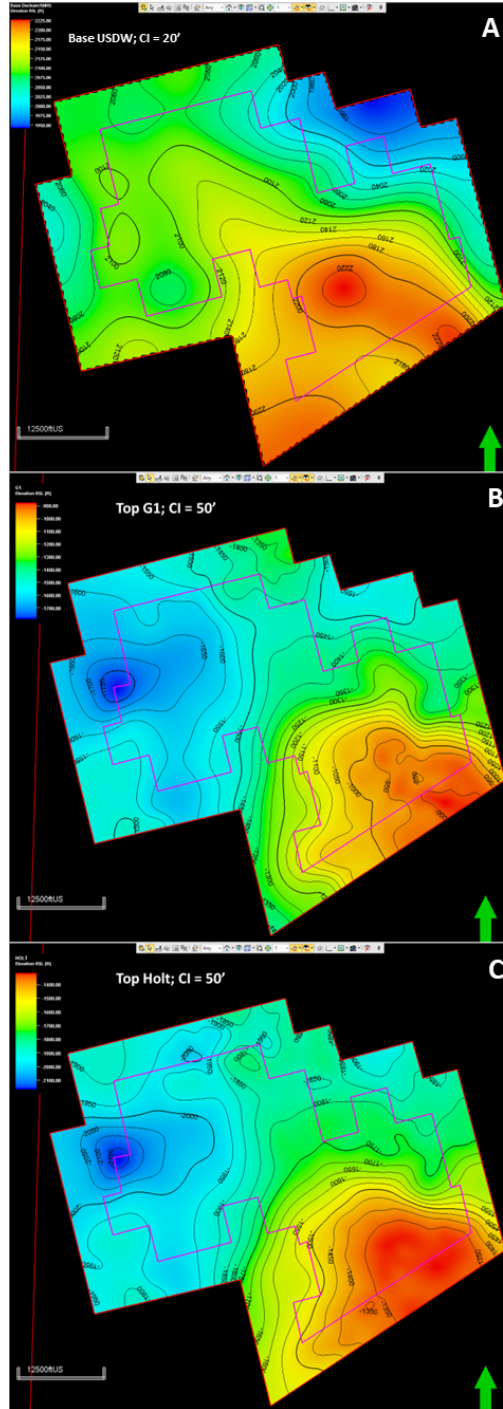

Figure 69—Structure maps for the Base USDW (A), Top G1 upper porosity interval in the Injection Zone (B), and Top Holt lower porosity interval in Injection Zone.

Hypothetical wells are placed at several locations in the simulation model to test sensitivities in the relationship between the overpressure due to injection (difference between pressure at end of injection period and initial pressure) at the top of the Lower San Andres Formation and the volume

of brine that could hypothetically leak into the lowermost USDW. In total, 28 hypothetical wells were positioned at different locations (i.e., 28 simulation runs). Figure 70 shows the relationship between leak rate and the overpressure due to injection in January 2037 (i.e., time of highest pressure in reservoir). Some pressure values are negative because the brine producers lower the reservoir pressure below initial pressure in the Injection Zone. The Injection Zone pressure and the leakage rate have acceptable correlation using a cubic equation, with R^2 approximately 0.96.

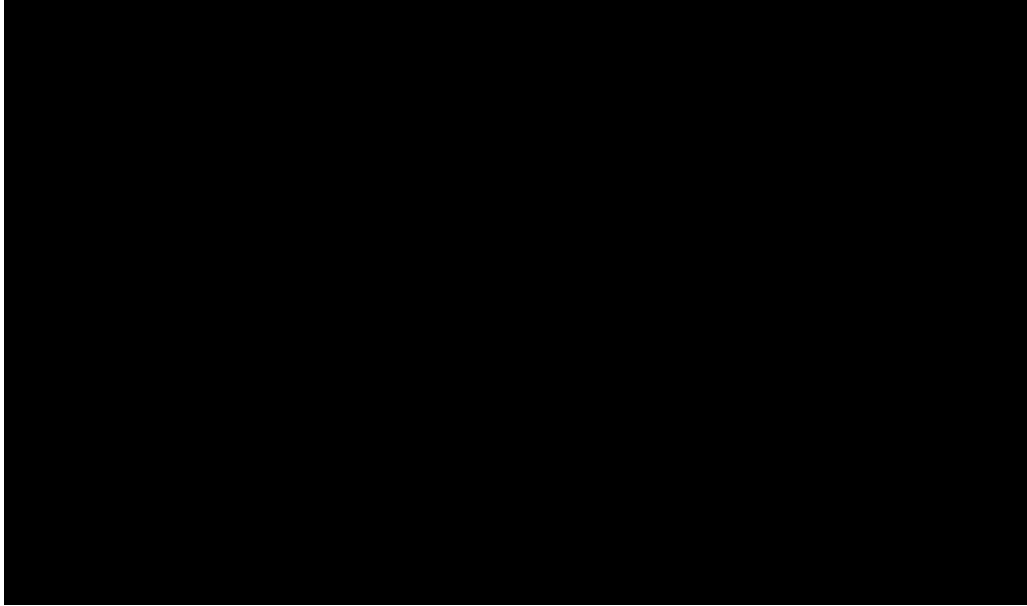

Figure 70—Leak rate for hypothetical wells versus overpressure due to injection in the top of the Lower San Andres (G1 sub-zone) in January 2037.

Simulations were conducted to evaluate the brine leakage potential for historical Artificial Penetrations (AP) inside the AoI. In total, nine APs were simulated using the same assumptions listed above. Figure 71 shows the AP locations in the AoI. Figure 72 shows the influx (leak) rate and the cumulative influx in the USDW for each of the Aps evaluated. If left unmitigated, these APs could potentially leak to the USDW: Eidson E-1 (API 4213531130) with maximum about 0.00022 bbl/day; Eidson-Scharbauer-1 (API 4213506139) with maximum about 0.00024 bbl/day, and Scharbauer Eidson-1 (API 4213510667) with maximum about 0.00023 bbl/day. All other APs have either zero or negative leak rates (due to depletion from brine withdrawal wells).

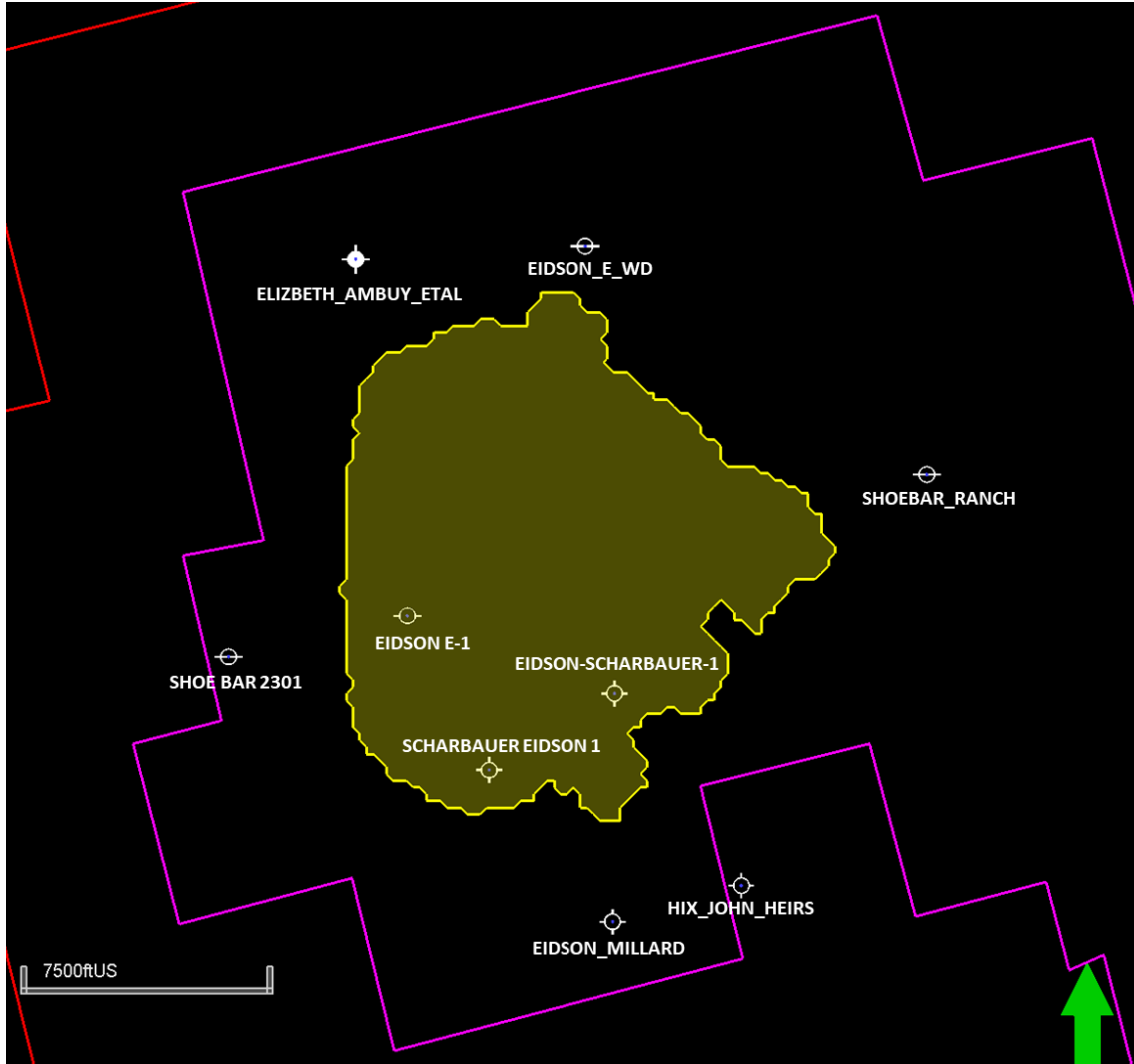

Figure 71—Map with the location of the nine legacy wells tested in the leakage modeling.

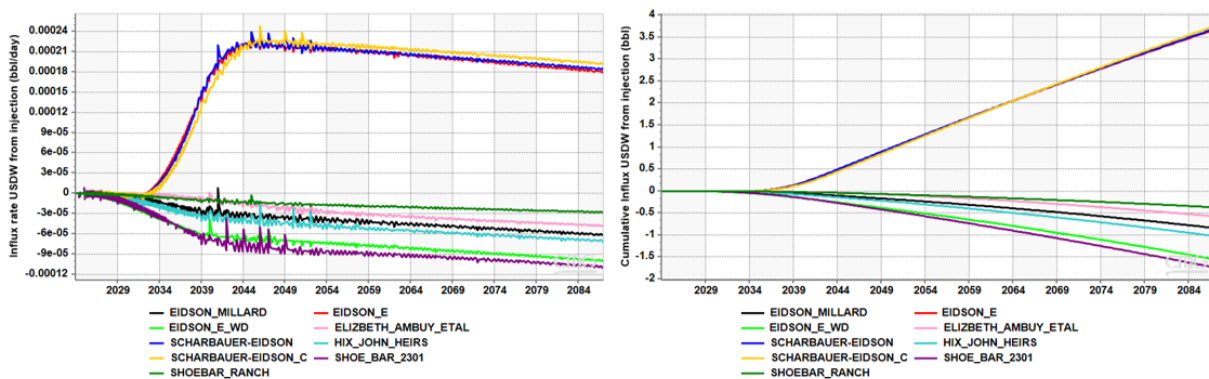

Figure 72—Leak rate and cumulative volume influx in the USDW for AP versus time. Negative values represent outflux from the USDW due to depletion from initial pressure.

Thus, for the delineation of the critical pressure, a maximum leak of about 0.0005 bbl/day (double the maximum rate) is assumed, which correlates with a pressure increase in relation to initial pressure (injection overpressure) in the top of the Lower San Andres Formation of 62.2 psi (Figure 73). Applying a separation thickness between top of the Lower San Andres Formation and top of the Holt sub-zone of 450 ft and a gradient of 0.48 psi/ft, the critical pressure for the top of the Holt sub-zone is $62.2 + 450 \times 0.48 = 278.2$ psi.

Assuming (1) an aquifer volume of 3,928,360 acre-foot for the Dockum aquifer in Ector County (Bradley and Kalaswad, 2003); (2) a leak rate for each AP well at a constant rate of 0.0005 bbl/day; (3) continuous leak for 62 years (Injection and PISC periods); and (4) APs are unmitigated; the total leakage due to CO₂ injection is 33.9 bbl, or just 8.34×10^{-8} % of the USDW.

Figure 73 (A, B, D, and E) is the initial pressure at the start of injection and the final pressure at end of the injection at the top of Lower San Andres and at the top of the Holt sub-zone. In addition, Figure 73 (C and F) shows the buffer pressure for exceeding the critical pressure threshold at the end of the injection period which is obtained from subtracting the initial pressure at the start of injection from the critical pressure calculated previously. The end of the injection period was selected because it is the highest pressure observed during simulation.

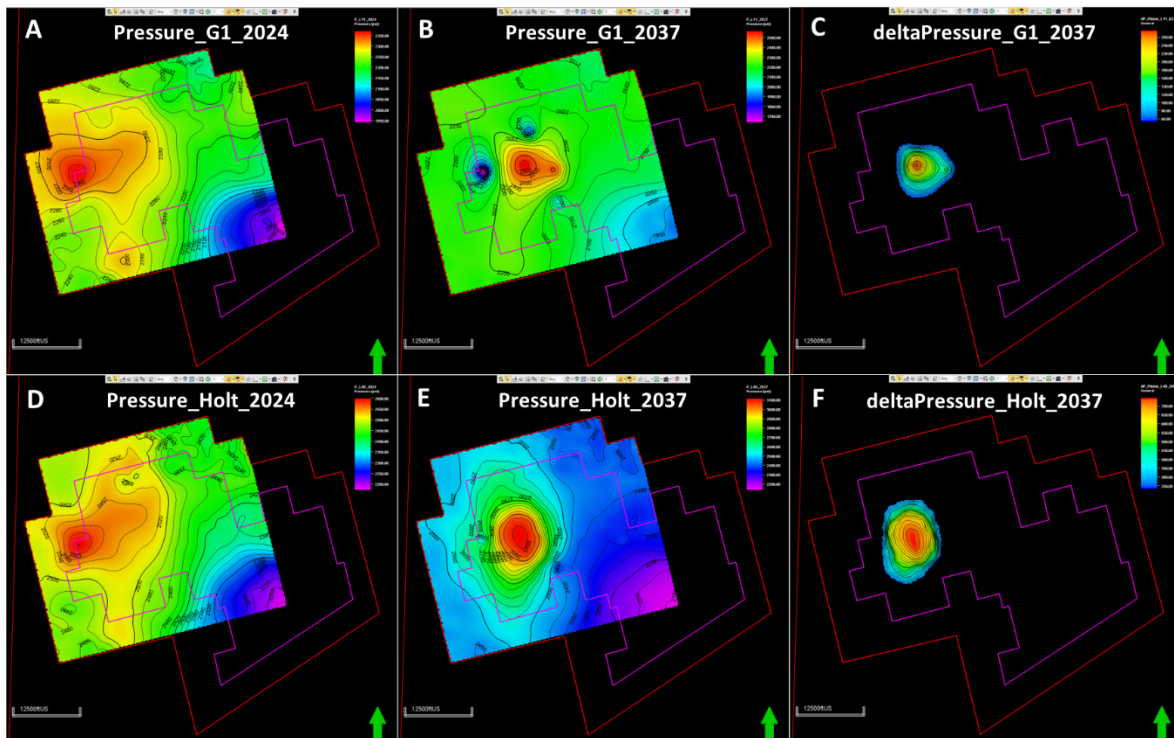

Figure 73—Pressure map for G1 sub-zone at initial time (A), at end of injection (B), and the difference map (C). Pressure map for Holt sub-zone at initial time (D), at the end of injection period (E), and the difference map (F).

4.2 AoR Delineation

4.2.1 Critical Pressure Front

The maximum differential pressure occurs at the time of maximum CO₂ cumulative injection in January 2037, because the wells are modeled to operate at a constant injection rate. Figure 74 shows the combined pressure at the time when injection ceases. Thus, the contour shown in Figure 74 represents the maximum extent of the pressure front found in the model.

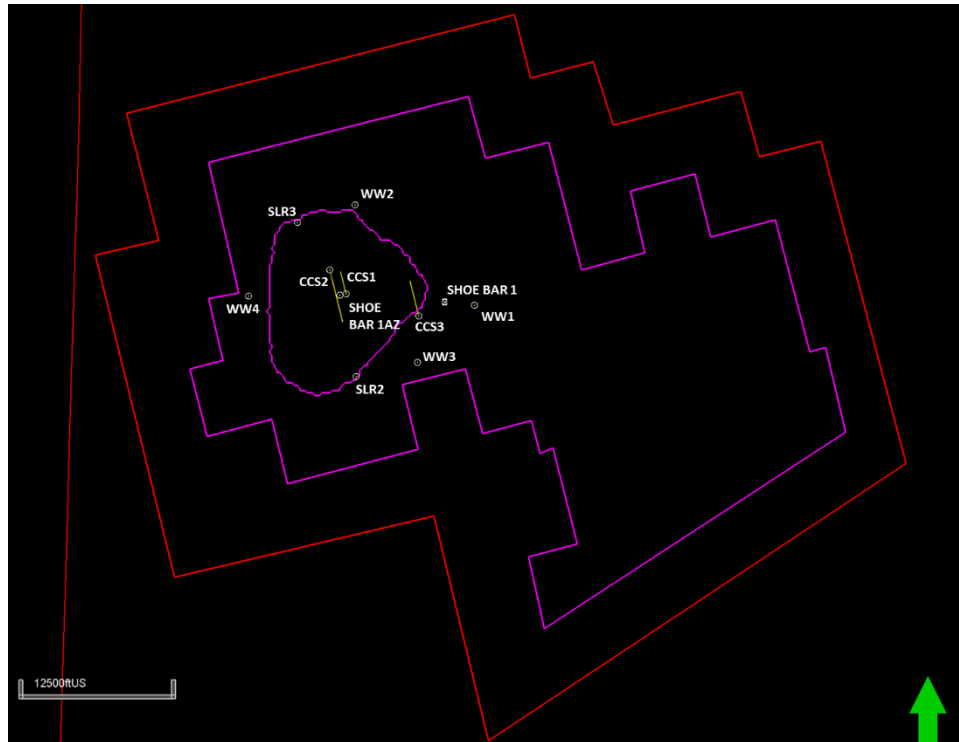

Figure 74—Maximum combined extent of pressure plumes for G4, G1, and Holt sub-zones at the end of injection in January 2037.

4.2.2 CO₂ Plume Extent

The CO₂ plume is shown as a projection of the global mole fraction of gas in the Injection Zone. The 3D property is first obtained by performing a cutoff of 0.1% to display the plume as any cells greater than the threshold value. Then the projection of all layers is performed in the map. The plume is within the boundaries of the brine producer wells. Figure 76 illustrates the CO₂ plume extent in 3D after injection ceases in January 2037, which is the maximum extent during simulation.

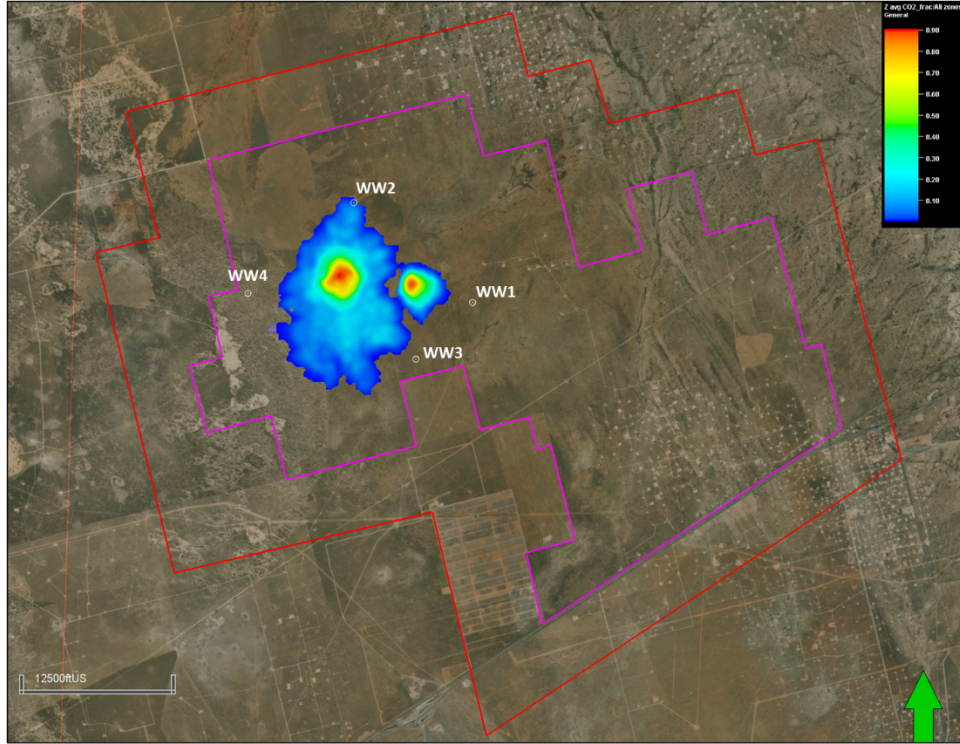

Figure 75—Areal extent of the vertically averaged maximum CO₂ plume extent at the end of injection in January 2037. Note that brine withdrawal in well WW2 occurs in the G4 and G1 sub-zones of the Lower San Andres and does not come in contact with 2D projection of the CO₂ plume extent projected from the Holt sub-zone (lower part of Lower San Andres).

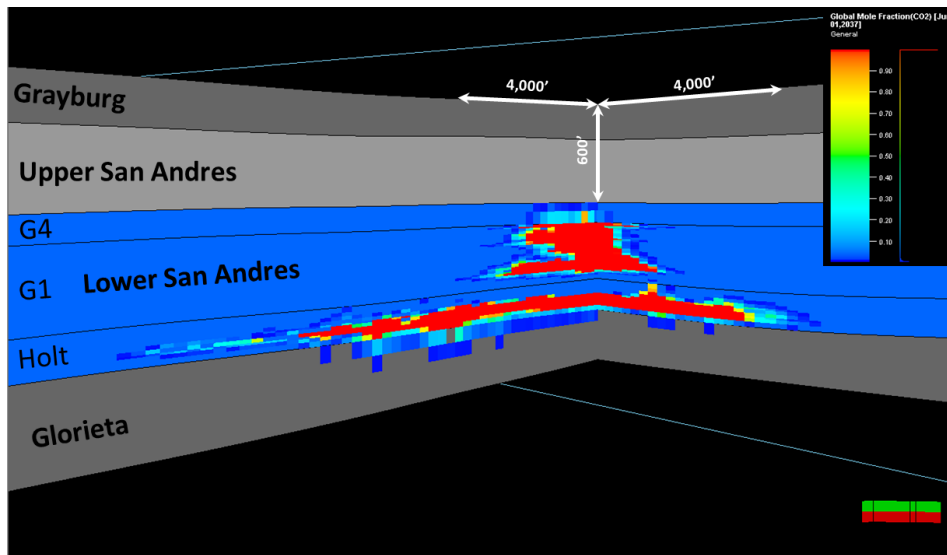

Figure 76—3D view of the maximum CO₂ plume extent, occurring at the end of injection in January 2037 (3X vertical exaggeration).

4.2.3 Final Area of Review

The final AoR (Figure 77) is the combination of the maximum pressure front (Figure 74) and the maximum CO₂ plume (Figure 75). The predicted evolution of the CO₂ plume and pressure front relative to the monitoring locations is shown in the Post-Injection Site Care (PISC) and Site Closure Plan document of this permit.

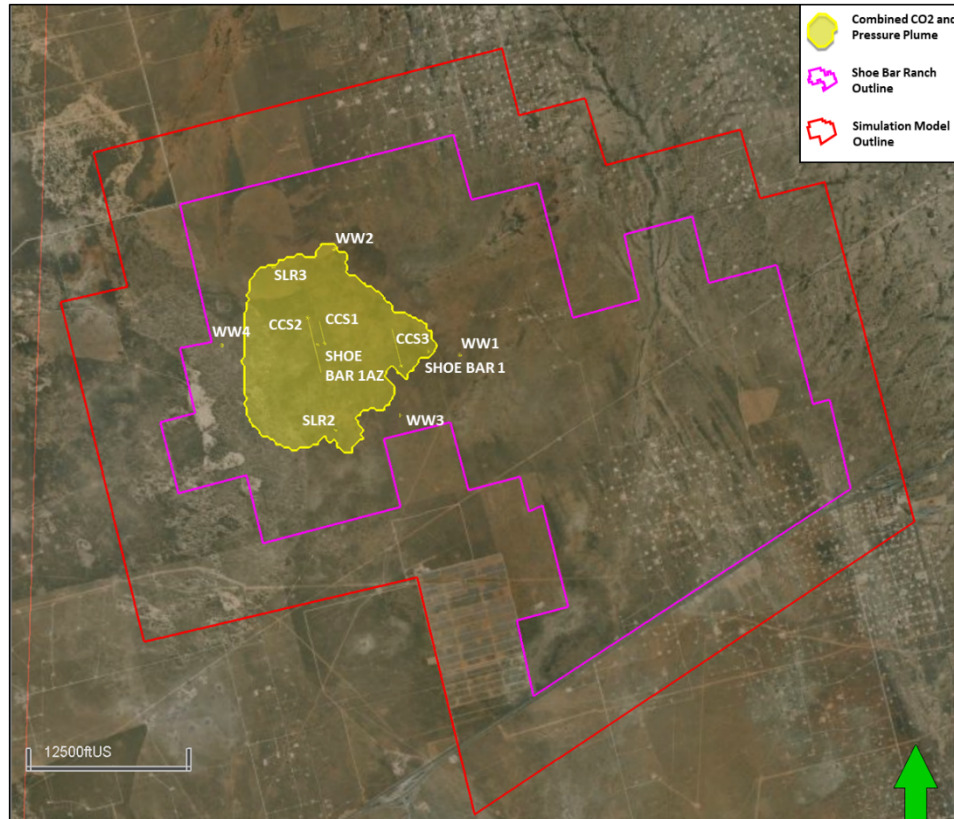

Figure 77—Combined AoR showing pressure and CO₂ plumes along with proposed injection wells (BRP CCS1-CCS3), stratigraphic wells (Shoe Bar 1 and Shoe Bar 1AZ), water withdrawal wells (WW1 - WW4), Injection Zone monitoring wells (SLR2 and SLR3), and Upper Confining Zone monitoring well (ACZ1).

5.0 Corrective Action

5.1 Tabulation of Wells Within the AoR

The BPR Project will utilize three CO₂ injection wells. The AoR represents the maximum extent of pressure from three wells at the end of 12 years of CO₂ injection and the maximum extent of the CO₂ plume 50 years after injection ceases. The AoR is modeled to be approximately 5.4 square miles.

OLCV conducted an airborne magnetic survey in May 2023 to identify and/or to confirm the location of existing artificial penetrations in the AoR. The data from this survey was analyzed and interpreted by Oxy and OLCV geophysicists. Magnetic anomalies were cross-referenced with aerial photos, drone photographic surveys, and physical site observation where necessary. See Appendix B for additional details on identifying APs.

In addition to airborne magnetic data, OLCV consulted the following databases to identify APs: TRRC, TCEQ, Texas Department of Licensing and Regulation (TDLR), Texas Water Development Board (TWDB), and the Texas Bureau of Economic Geology (BEG). Through this evaluation, OLCV identified two well locations that were incorrectly recorded in licensed databases such as IHS. OLCV cross-checked the recorded latitude and longitude with public well records, airborne magnetic survey, and drone imagery to confirm the appropriate well locations.

Excluding the wells drilled for the project: Shoe Bar 1, Shoe Bar 1AZ, Shoe Bar Ranch 1WW, Shoe Bar Ranch 2WW, Shoe Bar Ranch 3WW, Shoe Bar Ranch 4WW, and Shoe Bar USDW1; OLCV identified a total of four other APs in the AoR: three plugged wells related to oil and gas operations and one well used for USDW brine production. See Tables 16 and 17 below for tabulated well information. Additional information on all data sources consulted to identify AP is presented in Appendix B. OLCV will periodically re-evaluate the AoR and expand the tabulation of APs, as needed.

Table 16—Locations of existing wells in the AoR

					From Public and Licensed sources	
API or state well number	Well Name	Recorded Status	Drill Date	Abandon Date	Latitude NAD27	Longitude NAD27
4213543920	Shoe Bar 1	Stratigraphic test well	1/2/2023	NA	31.76343602	-102.7034981
4213543977	Shoe Bar 1AZ	Stratigraphic test well	7/29/2023	NA	31.76448869	-102.7305326
NA	Shoe Bar USDW1	Monitor	12/23/2023	NA	31.7641190	-102.7316750
4213544034	Shoe Bar Ranch 4WW	Water supply well	3/26/2024	NA	31.76384464	-102.7539505
4213544037	Shoe Bar Ranch 3WW	Water supply well	4/22/2024	NA	31.75008553	-102.7102206
4213544036	Shoe Bar Ranch 2WW	Water supply well	4/12/2024	NA	31.78419981	-102.7275869
4213544035	Shoe Bar Ranch 1WW	Water supply well	4/3/2024	NA	31.76289539	-102.6959232
4213506139	Eidson-Scharbauer-1	Dry hole, plugged	4/18/1958	9/21/1959	31.7526374	-102.7218925
4213510667	Scharbauer Eidson-1	Dry hole, plugged	12/23/1964	2/19/1965	31.7460090	-102.7343253
4213531130	Eidson E-1	Dry hole, plugged	8/1/1973	8/23/1973	31.7587481	-102.7431169
4511701	-	Brackish water producer; plugged	1940	9/20/2023	31.7719430	-102.7205540

5.1.1 Depth of the USDW in wells planned for corrective action

The Dockum is defined as the lowermost USDW in the AoR. The base of the USDW is picked on well log data from wells in the AoR with the exception of the Scharbauer Eidson-1 (API 4213510667) that does not have log data. The USDW was interpolated at this location based on well log correlation. See Appendix B for details on the depth of the USDW.

5.2 Corrective Action Plans and Schedule

5.2.1 Corrective Action Plan Overview

A detailed analysis was performed to evaluate the risk and timing of the plume and/or pressure front reaching each of the wells inside the AoR. The analysis was divided into two main categories to assess the risks and mitigations, based on the following possible mechanisms of failure:

- 1) **CO₂ plume corrosive effect and contamination of USDW aquifer.** The analysis focused on potential leakage paths from the Injection Zone that could endanger the USDW for those

wells that are projected to be exposed to the CO₂ plume. The lack of proper isolation, cement degradation by carbonic acid, mechanical barrier failures, and micro-annulus or casing corrosion are some of the situations that increase the risk of brine or CO₂ leaks.

- 2) **Pressure front effect with brine contamination from deeper saline reservoirs to USDW aquifers.** This category includes wells that were not projected to be in contact with the CO₂ plume but are inside the simulated pressure front. In this scenario, the wells were evaluated for proper hydraulic isolation between the Injection Zone and the USDW. The degradation or corrosion of cement, tubulars, and tools is not considered a high-risk scenario in this category.

5.2.2 Modeled Extent of AoR

OLCV modeled the extent of the AoR to determine which APs required corrective action and the timing of the corrective action. OLCV will conduct corrective action on three heritage APs: Eidson- E-1 (API 4213531130), Scharbauer Eidson-1 (API 4213510667) and Eidson Scharbauer-1 (API 4213506139) prior to commencement of CO₂ injection operations.

1) Simulation of three years of injection

During the first three years of injection (Figure 78), the simulated CO₂ plume does not reach any APs. However, the pressure front reaches the well **Eidson E-1** (API 4213531130) in the Holt sub-zone of the Lower San Andres in this time period. Corrective actions are proposed and will be executed prior to the commencement of injection operations. The monitoring network (as described in the Testing and Monitoring Plan document of this permit application) will be in place. Data gathering for pressure, temperature, and CO₂ saturation in the injectors and monitoring wells will be used to track pressure and CO₂ movement, calibrate the simulation model, and validate the AoR in the initial years of injection.

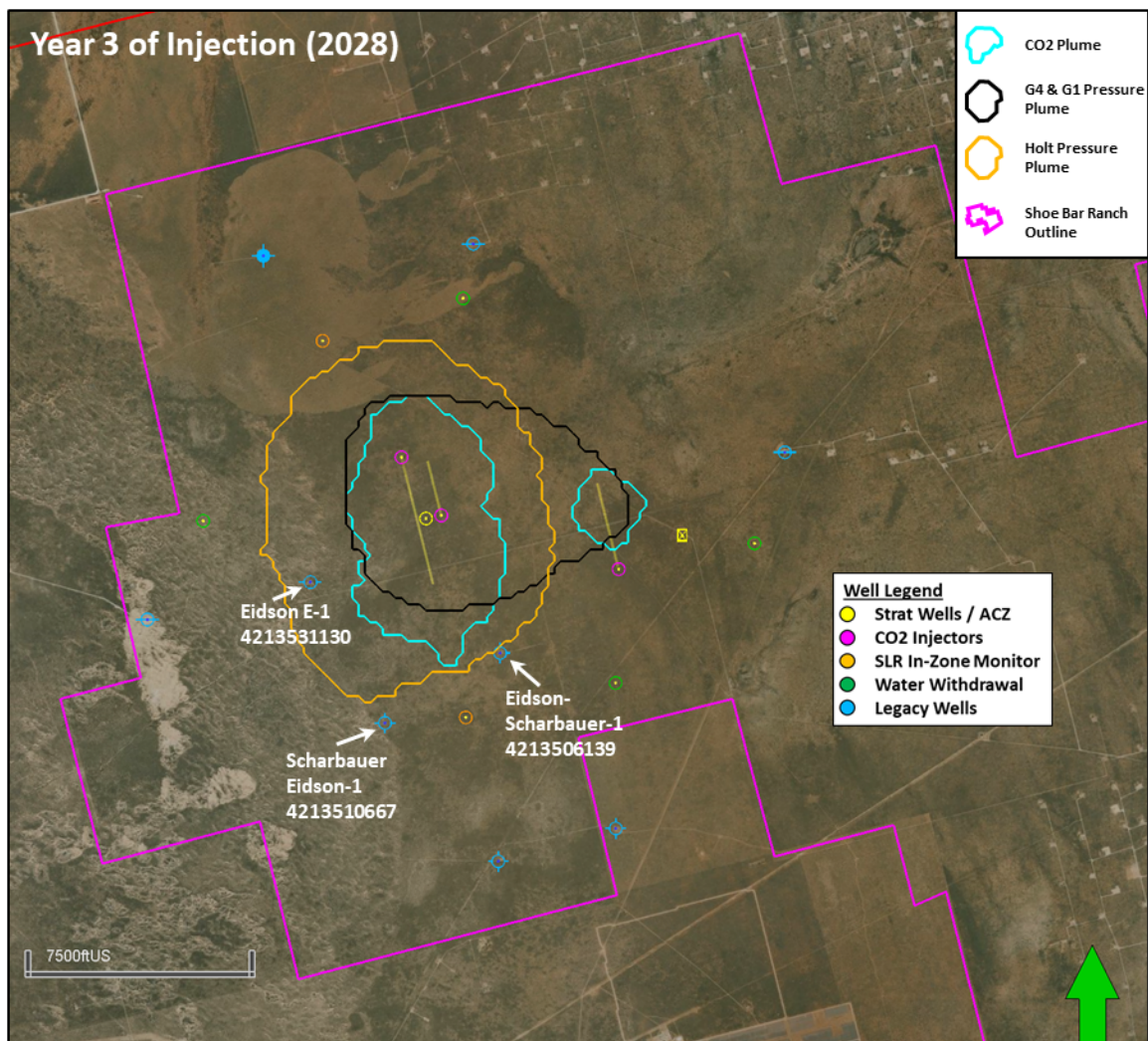

Figure 78—Three Years of injection, showing that the Holt sub-zone pressure plume reaches legacy well EIDSON E-1.

2) Simulation after five years of injection

From the second to fifth year of injection (Figure 79), the simulated CO₂ plume does not reach any APs. The pressure front reaches the **Eidson-Scharbauer-1** (API 4213506139) and **Scharbauer Eidson-1** (API 4213510667) at the Holt sub-zone of the Lower San Andres, as shown in Figure 79. Because OLCV will have already conducted corrective action on this AP, there is no expected impact to the USDW.

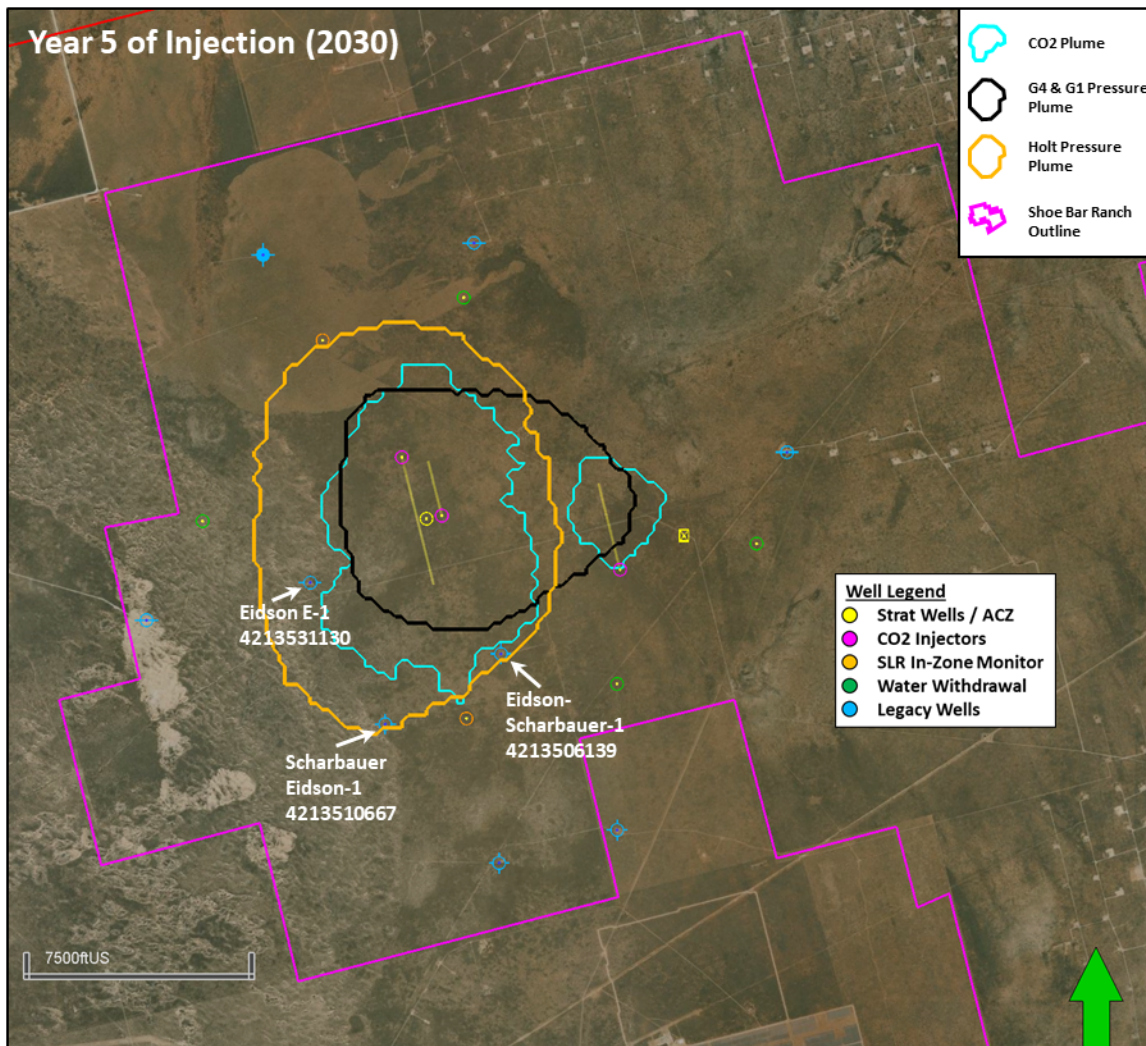

Figure 79—CO₂ plume and critical pressure front extent after 5 years of injection.

3) Simulation after seven years of injection

In the seventh year of injection, the simulated CO₂ plume reaches AP **Eidson-Scharbauer-1** (API 4213506139), as shown in Figure 80. Because OLCV will have already conducted corrective action on this AP, there is no expected impact to the USDW.

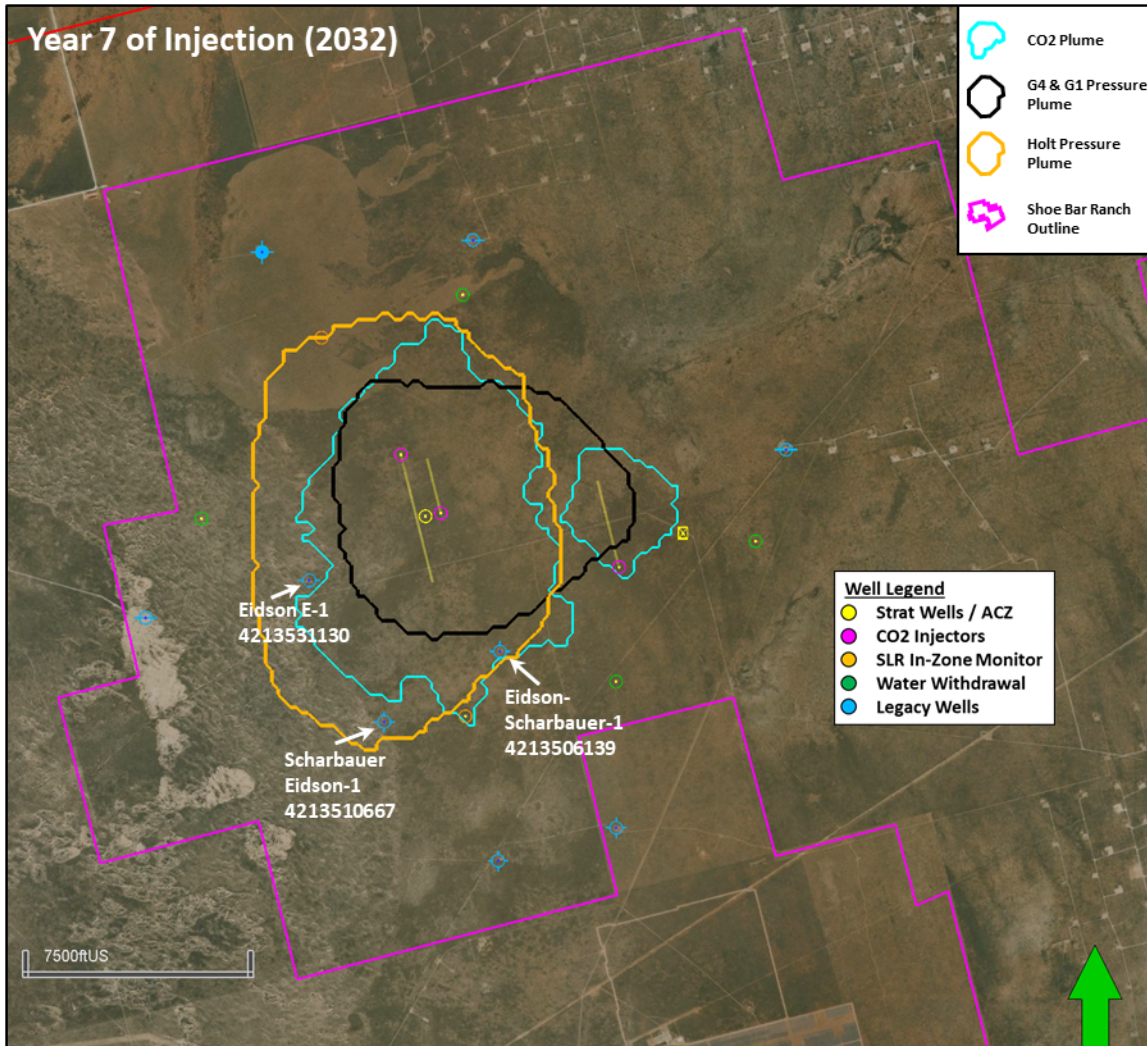

Figure 80—CO₂ plume and critical pressure front extent after 7 years of injection.

4) Simulation after 12 years of injection

By the twelfth year after the commencement of injection, the simulated CO₂ plume reaches APs **Scharbauer Eidson-1** (API 4213510667) and **Eidson E-1** (API 4213531130), as shown in Figure 81. The modeled CO₂ plume and critical pressure front reaches its maximum area and value when injection ceases. The size of the CO₂ and pressure plumes slightly shrink after the cessation of injection. Figure 82 shows the modeled CO₂ plume and critical pressure front extent 50 years after the end of injection. Because OLCV will have conducted corrective action on these APs by this time, the risk of leakage to the USDW is mitigated.

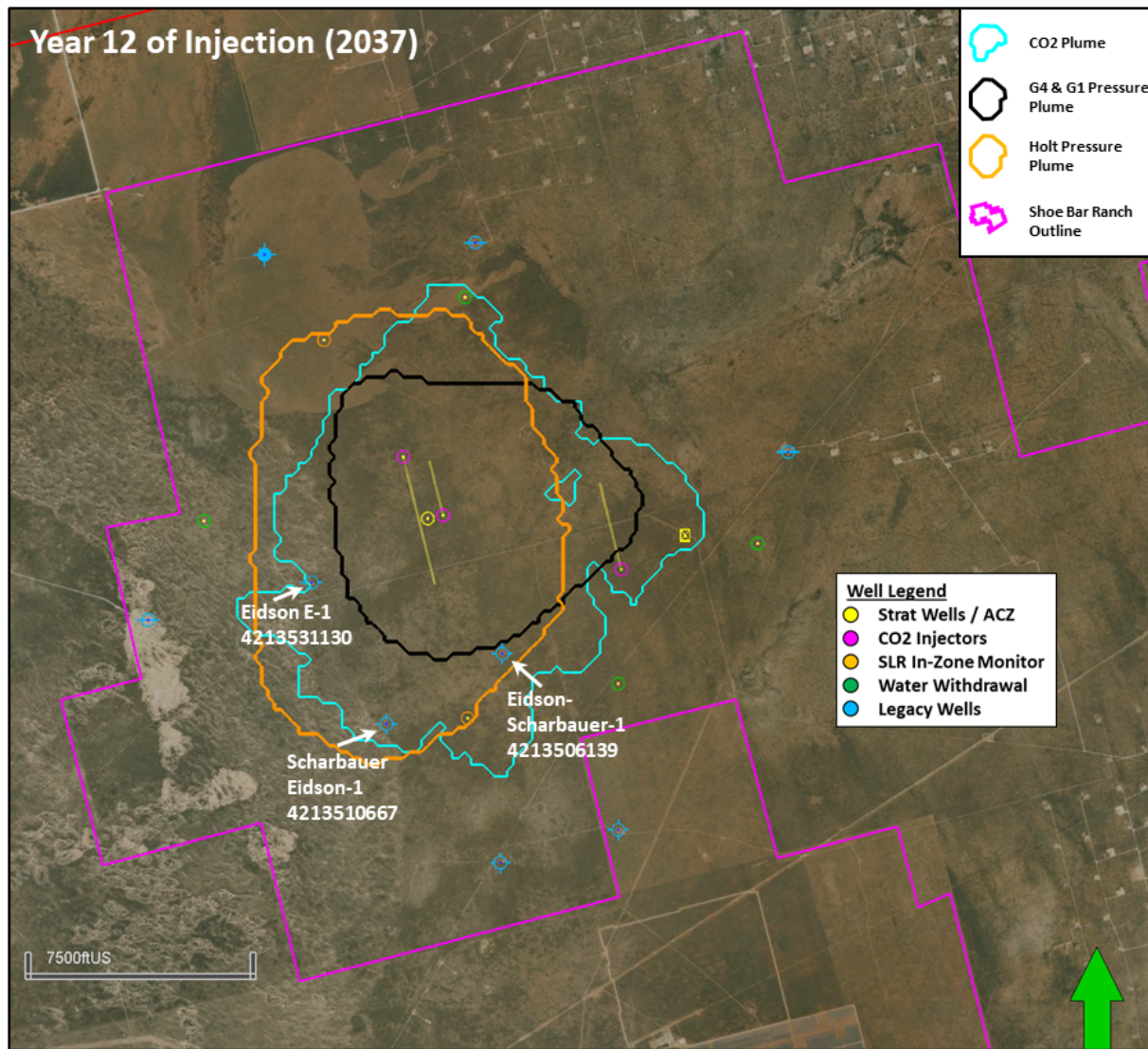
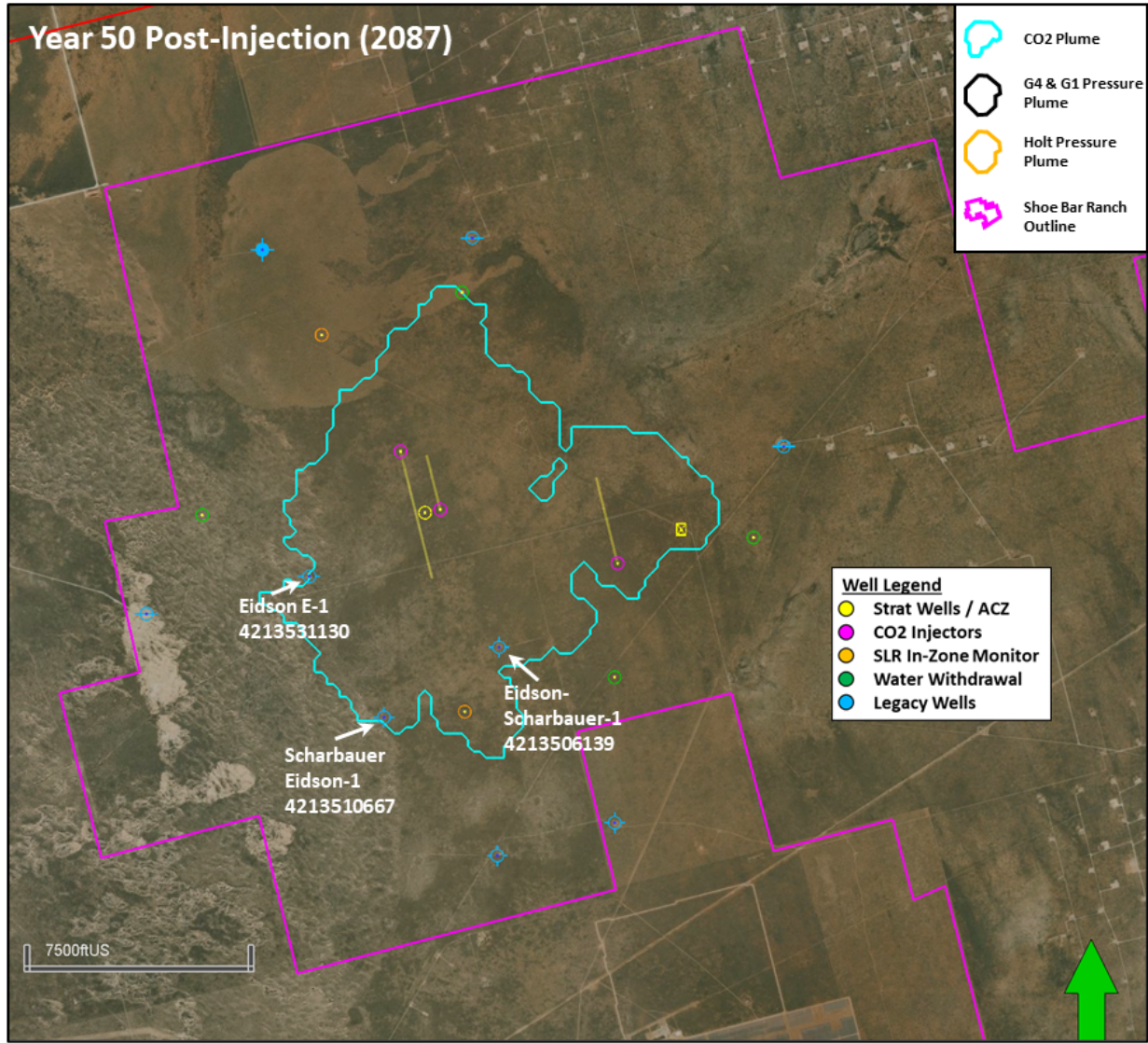

Figure 81—CO₂ plume and critical pressure front extent after 12 years of injection. Note that CO₂ plume reaches WW2 in map view but only in the Holt sub-zone and WW2 is a dedicated G4 and G1 sub-zone water withdrawal well.



compre

Figure 82—CO₂ plume and critical pressure front extent 50 years after the end of injection. Note that pressure in the G1, G4 and Holt sub-zones has dissipated below the critical pressure by this point in time.

5.2.3 Timing of Corrective Action

The AoR defined by critical pressure is modeled to reach the Eidson E-1 (API 4213531130) within approximately two years following the commencement of CO₂ injection. This well will require corrective action. That action will be taken prior to the commencement of CO₂ injection operations.

The AoR defined by critical pressure is modeled to reach the Eidson-Scharbauer-1 (API 4213506139) and the Scharbauer Eidson-1 (API 4213510667) within approximately five years after the commencement of CO₂ injection. These wells will require corrective action. The corrective action will be performed prior to the commencement of CO₂ injection operations.

OLCV and a third-party water drilling contractor conducted a site investigation in July 2023 and determined that well 4511701 should be plugged and abandoned because of a shallow hole obstruction possibly due to casing corrosion or sanding event. The well was plugged and abandoned according to TCEQ standards in September 2023. No further remedial action is required on this well.

OLCV will evaluate Project data and re-evaluate the AoR on a regular basis, and at least every five years. OLCV will use data collected from injection and monitoring wells and indirect geophysical data to compare with predicted results from the dynamic simulation model. The model will be updated, if needed, to better match historical observations. If updated modeling work results in a re-delineation of the AoR, a revised corrective action plan and schedule will be completed pursuant to 40 CFR §146.84(d).

Corrective action plugging procedures for Eidson E-1 (API 4213531130), Eidson-Scharbauer-1 (API 4213506139), and the Scharbauer Eidson-1 (API 4213510667) are shown below. Please refer to Appendix A of the Plugging Plan for plugging procedures and diagrams for the other project wells currently constructed: USDW1, WW1, WW2, WW3, WW4, SLR1 and ACZ1 wells.

Table 17—Corrective action date for APs in AoR

API or state well number	Well Name	Planned actions	Date of corrective action and/or plugging
4511701	-	Remediation performed; plugged	2023
4213543920	Shoe Bar 1	Utilize as monitor during injection and post-injection periods before final plugging	2024 ¹ and ~10 years post Injection Period
4213543977	Shoe Bar 1AZ	Utilize as monitor during injection and post-injection periods before final plugging	2024 ¹ , ~10 years post Injection Period
4213506139	Eidson-Scharbauer-1	Remediate	2025, prior to Injection Period
4213510667	Scharbauer Eidson-1	Remediate	2025, prior to Injection Period
4213531130	Eidson E-1	Remediate	2025, prior to Injection Period
4213544035	Shoe Bar 1WW	Brine water withdrawal	End of Injection Period
4213544036	Shoe Bar 2WW	Brine water withdrawal	After ~seven years of injection ² End of Injection Period
4213544037	Shoe Bar 3WW	Brine water withdrawal	End of Injection Period
4213544034	Shoe Bar 4WW	Brine water withdrawal	End of Injection Period
NA	Shoe Bar 1USDW	USDW monitor	~20 years post Injection Period

¹Plugging to convert stratigraphic test well into a monitoring well

²Plugging of the Holt sub-zone

5.2.4 Corrective Action Procedures

5.2.4.1 Eidson E-1 Re-entry and Plugging Procedure



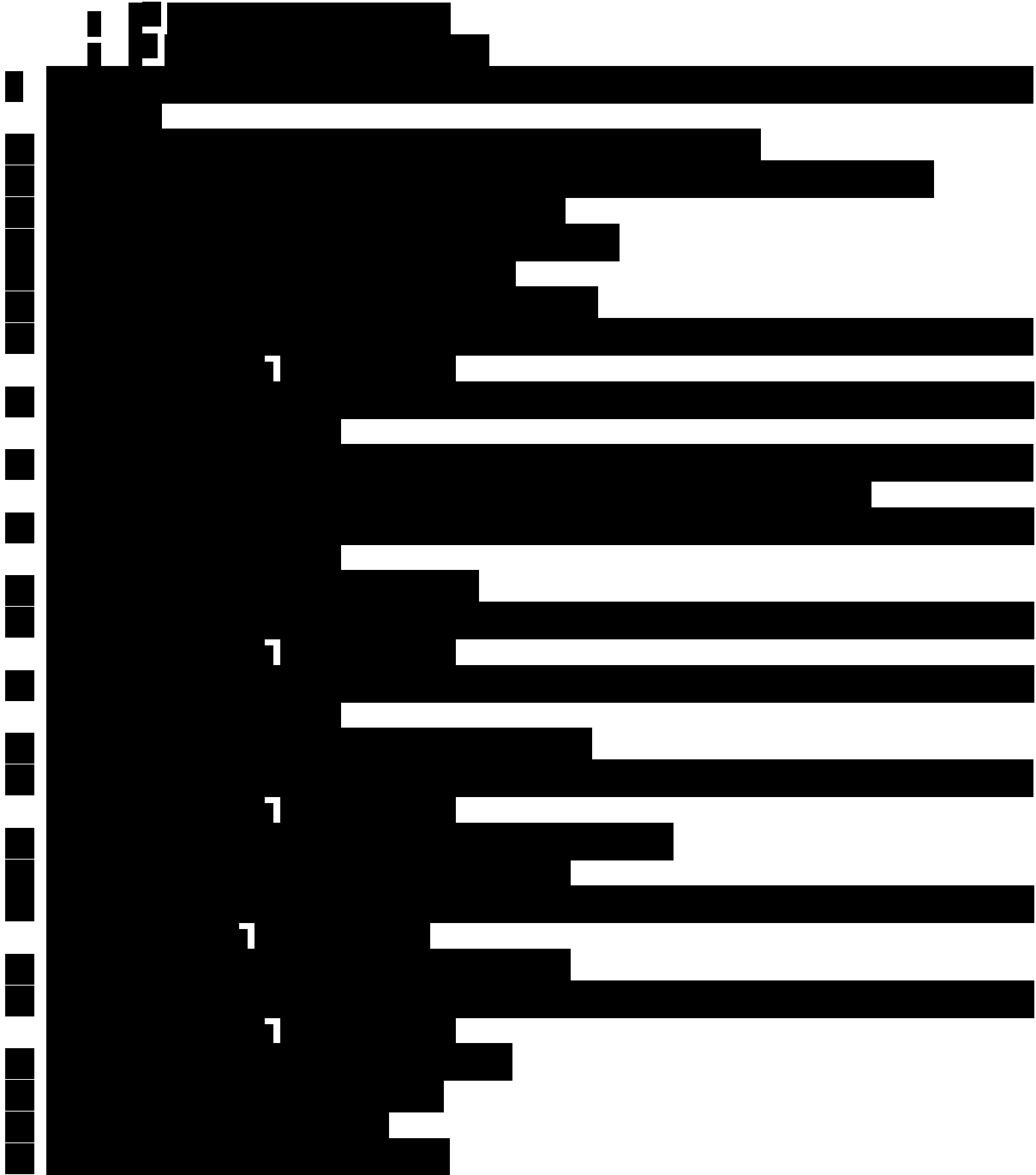

The current wellbore diagram for Eidson E-1 is show in Figure 83. The proposed wellbore diagram after corrective action is shown in Figure 84.

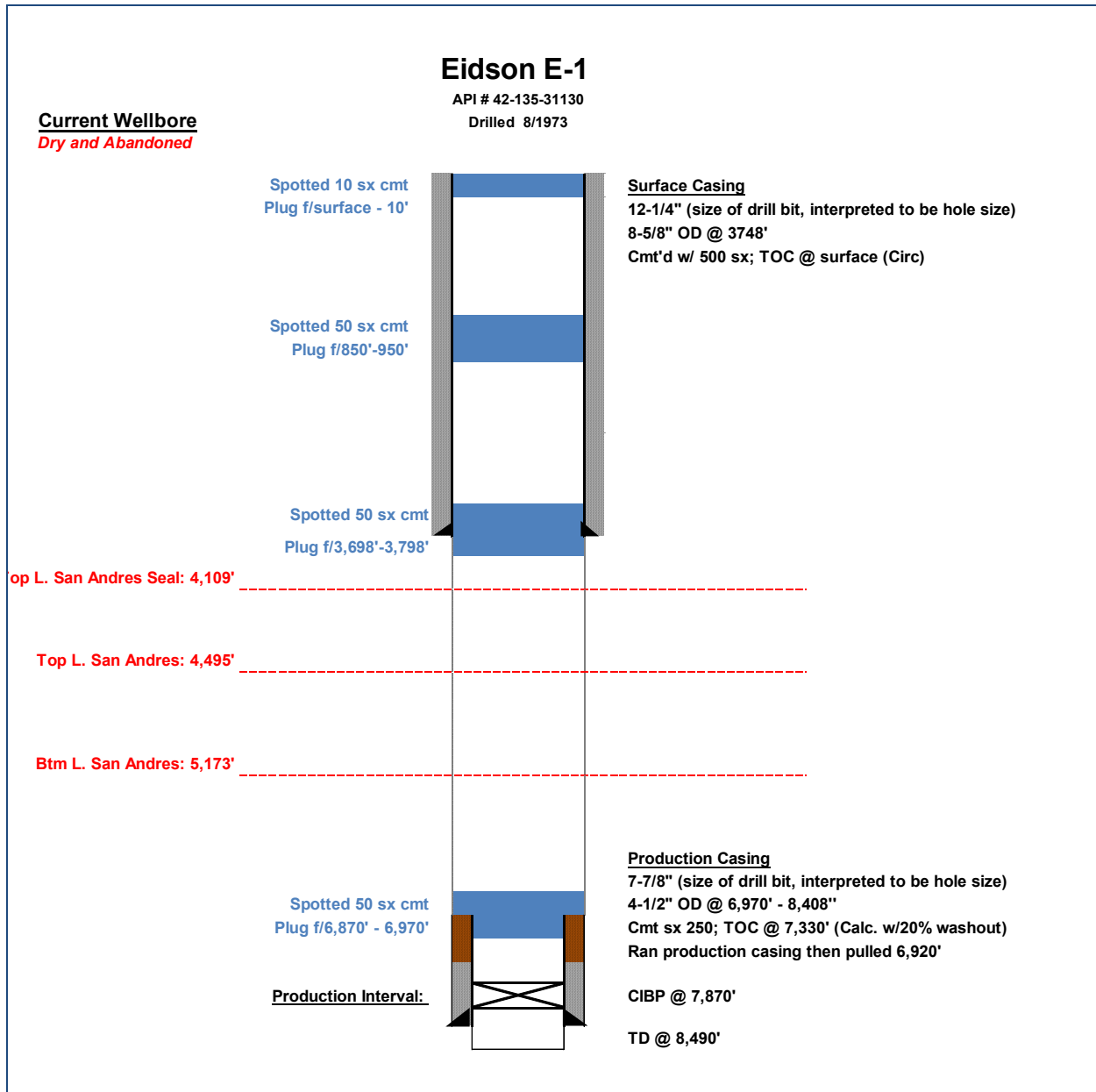

Figure 831—Eidson E-1 current wellbore diagram.

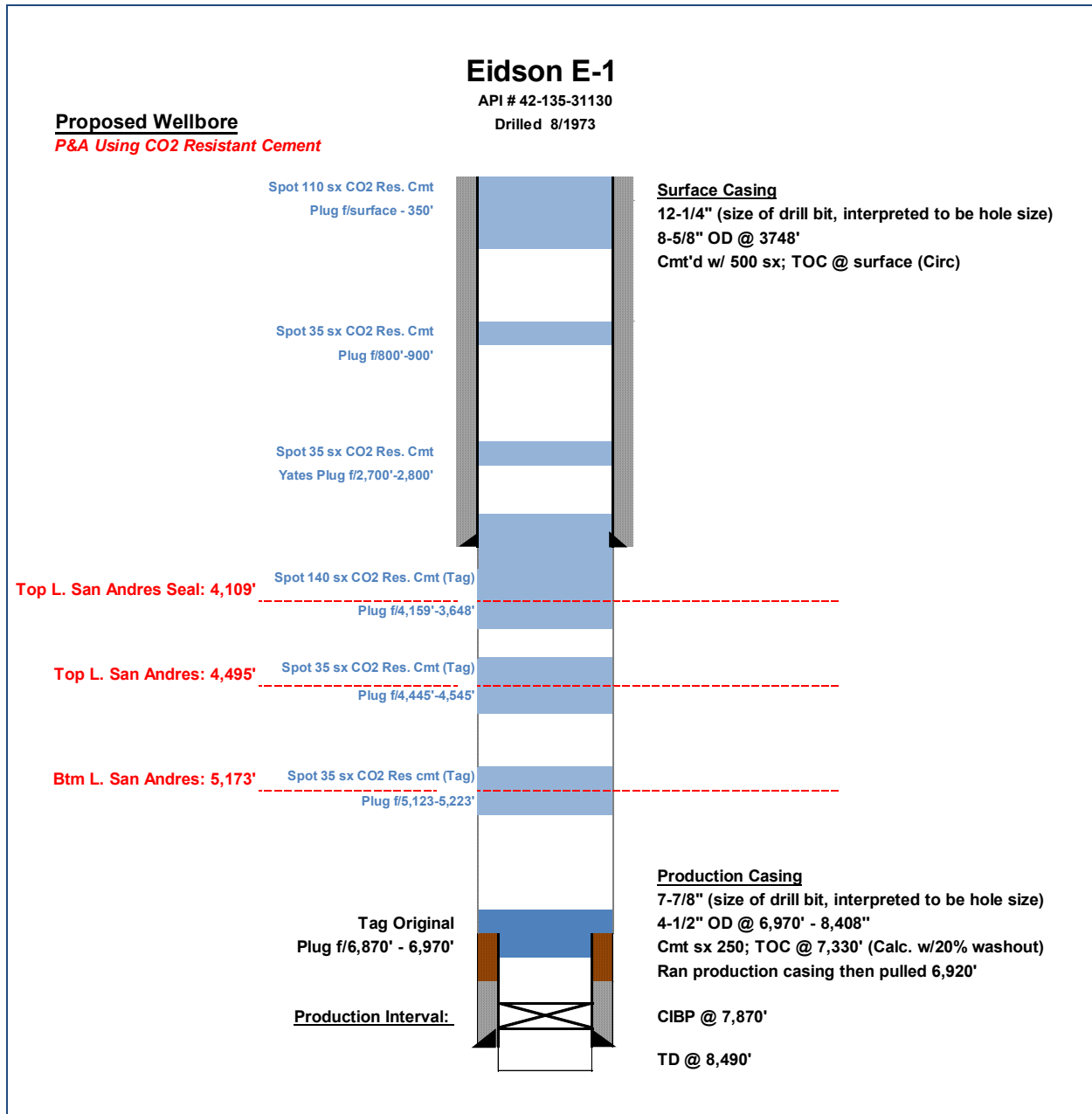

Figure 84--Proposed wellbore diagram of Eidson E-1 after corrective action.

5.2.4.2 Scharbauer Eidson-1 Re-entry and Plugging Procedure



[REDACTED]

The current wellbore diagram for Scharbauer Eidson 1 is shown in Figure 85. The proposed wellbore diagram is shown in Figure 86.

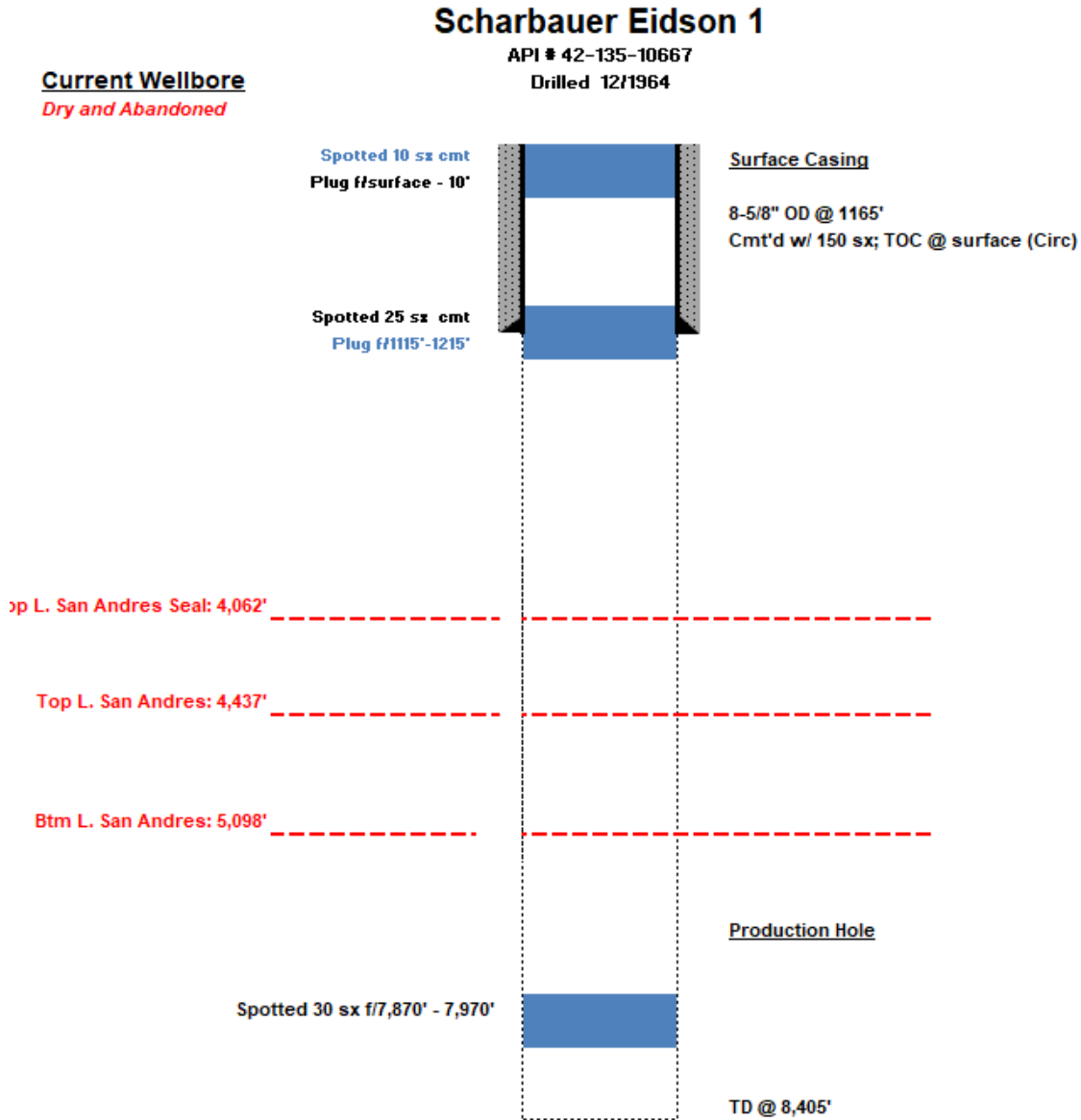

Figure 85--Current Scharbauer Eidson-1 wellbore diagram.

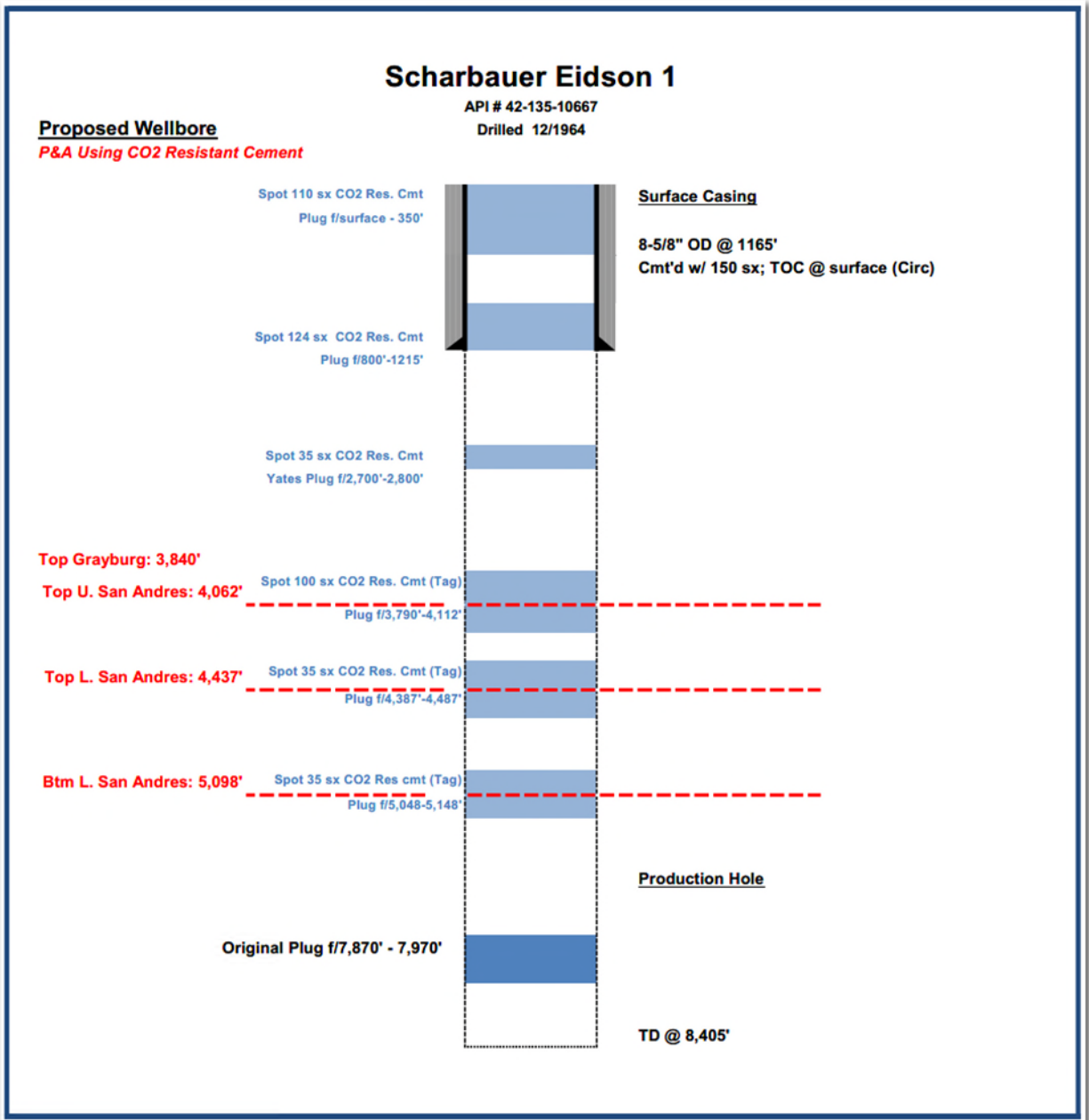

Figure 86—Proposed wellbore diagram for Scharbauer Eidson-1 after corrective action.

5.2.4.3 Eidson- Scharbauer-1 Re-entry and Plugging Procedure



[REDACTED]

Plan revision number: 3
Plan revision date: 07/30/2024

The current wellbore diagram for Eidson-Scharbauer-1 is shown in Figure 87. The proposed wellbore diagram is shown in Figure 88.

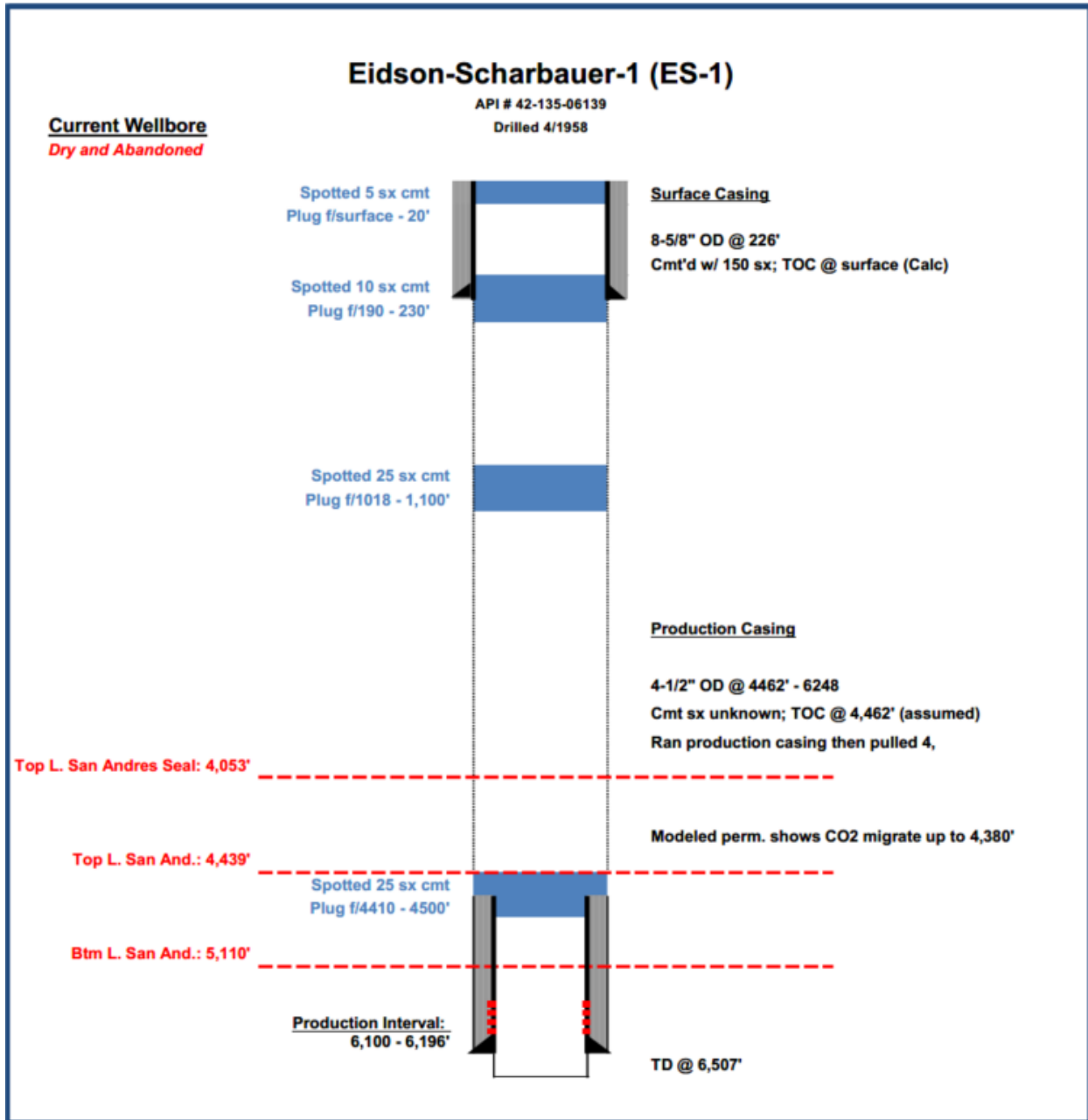

Figure 87—Current Eidson-Scharbauer-1 wellbore diagram.

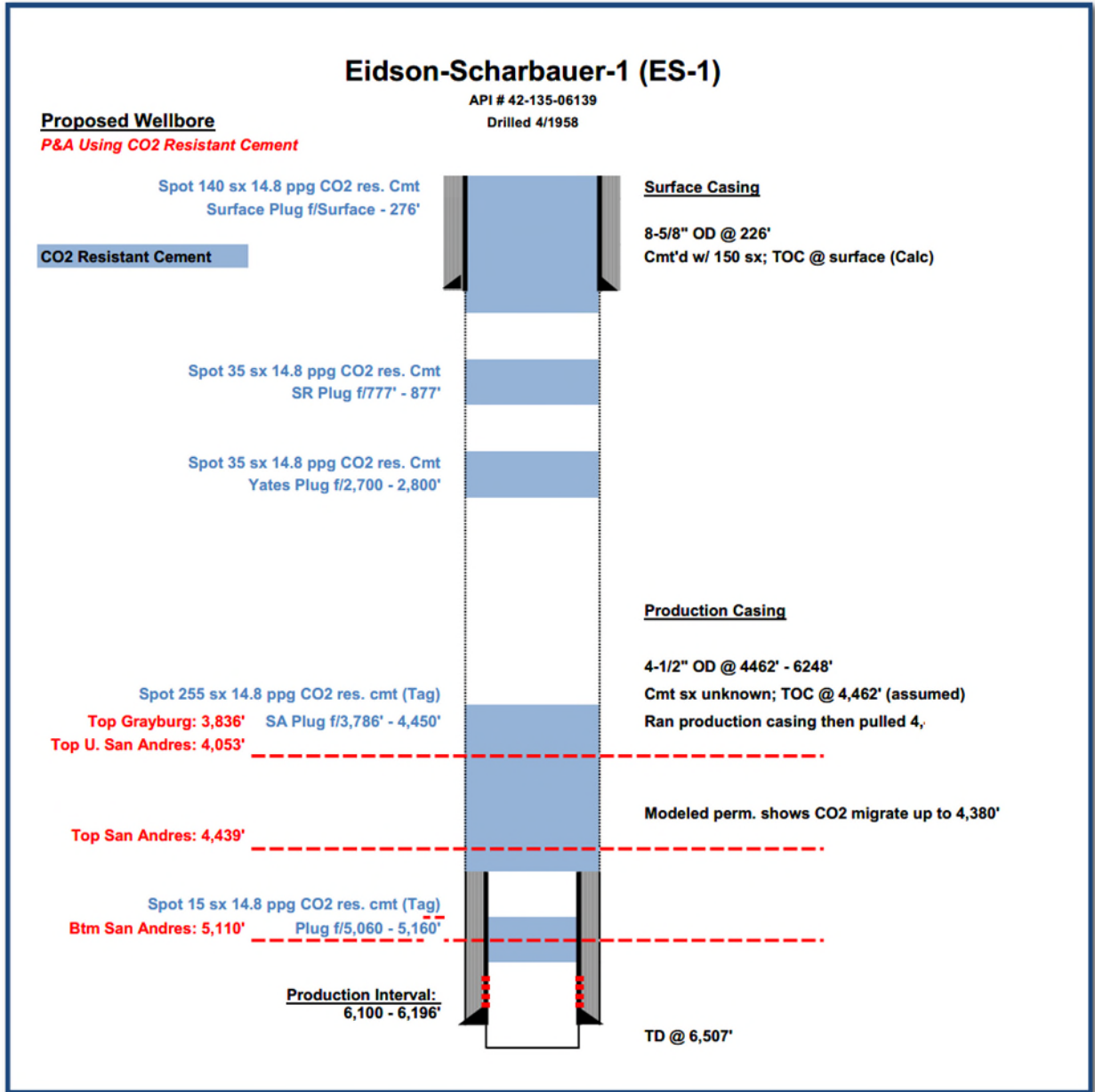

Figure 88—Proposed Eidson-Scharbauer-1 wellbore diagram following corrective action.

5.2.4.4 Plugging procedures for other Project wells

See Appendix A to the Plugging plan that is part of this document for a description of plugging plans for the Shoe Bar 1, Shoe Bar 1AZ, Shoe Bar 1WW, Shoe Bar 2WW, Shoe Bar 3WW, Shoe Bar 4WW, and the USDW1 well.

5.3 Plan for Site Access

As part of OLCV's agreement with the Shoe Bar Ranch, the operator acquired the exclusive rights to sequester and store liquids, gases, and other substances in the property. With that, OLCV has the right to maintain and operate any and all equipment necessary or useful to sequestration operations. The term of the agreement is in effect until 100 years after the cessation of sequestration operations, unless the operator elects to abandon earlier.

6.0 Re-Evaluation Schedule and Criteria

6.1 AoR Re-Evaluation Cycle

OLCV will re-evaluate the AoR every five years during the injection and post-injection phases. In addition, monitoring and operational data will be reviewed periodically by OLCV during the injection and post-injection phases.

Activities to be performed during re-evaluation include:

- Review and analyze available monitoring and operational data and compare these data to the dynamic simulation forecast to assess whether the predicted CO₂ plume migration is consistent with the observed data. OLCV will incorporate direct monitoring data from injector wells, reservoir-level monitoring well, above confining zone monitoring wells and USDW-level monitoring wells. In addition, OLCV will incorporate data from indirect geophysical monitoring. Data collection is described in the Testing and Monitoring Plan and PISC Plan that are included as part of this application. Specific steps of this review and analysis include:
 - (1) Review available data on the position of the CO₂ plume and pressure front, such as pressure and temperature monitoring data, Pulsed Neutron logs (PNL), fluid samples, DInSAR, and repeat Vertical Seismic Profile and/or 2D seismic data.
 - Correlate the time-lapse PNL and time-lapse VSP/2D data to locate and track the movement of the CO₂ plume. A good correlation between the two data sets will provide confidence in the model's ability to represent the storage complex.
 - Review downhole reservoir pressure data collected from various locations and intervals using a combination of surface and downhole pressure gauges.

- (2) Review water chemistry monitoring data collected in SLR wells and in the ACZ monitoring wells, verifying that there is no evidence of CO₂ or brines that represent an endangerment to any USDWs.
 - (3) Review operating data, e.g., injection rates and pressures, and verify they are consistent with the inputs used in the most recent modeling effort.
 - (4) Review geologic data acquired since the last modeling effort, e.g., additional site characterization performed or updates of petrophysical properties from core analysis. Identify whether new data are materially different from the modeling inputs and assumptions.
- Compare the results of computational modeling used for AoR delineation to the monitoring data collected. Monitoring data will be used to show that the computational model accurately represents the storage site and can be used as a proxy to determine the plume's properties and size. The degree of accuracy is demonstrated by comparing monitoring data with the model's predicted properties (i.e., plume location, rate of movement, and pressure decay). Statistical methods will be employed to correlate the data and confirm the model's ability to represent the storage site accurately.
 - If the current data are consistent with model inputs and/or if the model forecast is unchanged after incorporation of these data, no update to the AoR will be needed. In this case, a report including data and results will be prepared to demonstrate that no re-delineation of the AoR is needed.
 - If material changes in site conditions or operating parameters have occurred, or if data indicate that the actual plume or pressure front may extend beyond the modeled plume and pressure front, the AoR will be re-delineated. Steps to re-delineate the AoR include:
 - (1) Revise the site conceptual model based on the new site characterization, operational, or monitoring data.
 - (2) Calibrate and history-match the model to minimize the differences between monitoring data and model simulations.
 - Perform the AoR delineation phased approach as described in Section 4.0 AoR Delineation of this document. Review legacy AP within the AoR and perform corrective action on wells, if needed. Specific steps include:
 - (1) Identify any wells that fall within the AoR. Evaluate the status and records for wells that not previously evaluated and provide a description of each well's type, construction, date drilled, location, depth, and record of plugging and/or completion.
 - (2) Determine which wells in the newly delineated AoR are plugged in a manner that prevents movement of carbon dioxide or other fluids that may endanger USDWs.

(3) Perform corrective action on all deficient wells in the AoR using methods designed to prevent the movement of fluid into or between USDWs, including the use of materials compatible with carbon dioxide.

- Prepare a report documenting the AoR re-evaluation process, data evaluated, any corrective actions determined to be necessary, and status of corrective action or a schedule for any corrective actions to be performed. The report will be submitted to EPA within 90 days of the re-evaluation and will include maps that highlight similarities and differences with previous AoR delineations.
- Update the AoR and Corrective Action Plan to reflect the revised AoR, along with other related Project plans, as needed.

6.2 Conditions Warranting an AoR Re-Evaluation Prior to Scheduled Re-Evaluation

Unscheduled re-evaluation of the AoR will be based on quantitative changes observed in monitoring wells, including unexpected changes in the following parameters: pressure, temperature, RST/PNL, or fluid chemistry changes in deep groundwater (>3,800 ft). Changes in these parameters may indicate that the actual plume or pressure front may extend beyond the modeled plume and pressure front. These changes might include:

- **Pressure:** Changes in pressure that are unexpected and outside three standard deviations from the average will trigger a new evaluation of the AoR.
- **Temperature:** Changes in temperature that are unexpected and outside three standard deviations from the average will trigger a new evaluation of the AoR.
- **RST Saturation:** Increases in CO₂ saturation that indicate the movement of CO₂ into or above the Confining Zone will trigger a new evaluation of the AoR unless the changes are found to be related to well integrity. Any identified well integrity issues will be investigated and addressed. Increases in CO₂ saturation in monitoring wells may indicate an early breakthrough of the CO₂ plume.
- **Deep Groundwater Constituent Concentrations:** Unexpected changes in fluid constituent concentrations that indicate movement of CO₂ or brine into or above the Confining Zone will trigger a new evaluation of the AoR unless the changes are found to be related to wellbore integrity. Any identified well integrity issues will be investigated and addressed.
- **Exceeding Fracture Pressure Conditions:** Pressure in any of the injection or monitoring wells exceeding 90% of the geologic formation fracture pressure at the point of measurement will trigger a new evaluation of the AoR.

- **Compromise in Injection Well Mechanical Integrity:** A significant change in annular pressure for the injection well that indicates a loss of mechanical integrity or a failed mechanical integrity test (MIT) in an injector will trigger a new evaluation of the AoR.
- **Induced Seismicity Monitoring:** Seismic monitoring data that indicate reactivation of a fault or structures due to pressurization of the reservoir as a consequence of the CO₂ injection will trigger a new evaluation of the AoR. The Project will review the monitoring data to discard naturally occurring events not related to the injection.

An unscheduled AoR re-evaluation may be needed if it is likely that the actual plume or pressure front may extend beyond what was modeled because any of the following has occurred:

- Seismic event greater than M_L 3.5 within 5.6 miles of the injection well.
- Exceedance of any Class VI operating permit condition (e.g., exceeding the permitted volumes of carbon dioxide injected); or
- New site characterization data that change the computational model to such an extent that the predicted plume or pressure front extends vertically or horizontally beyond the predicted AoR.

OLCV will discuss any such events with the UIC Program Director to determine if an AoR re-evaluation is required. If an unscheduled re-evaluation is triggered, OLCV will perform the steps described in 6.1 AoR Re-Evaluation Cycle.

7.0 References

- Anaya, R. and Jones, I. C. 2009. Groundwater Availability Model for the Edwards-Trinity (Plateau) and Pecos Valley Aquifer Systems. Report 373, Texas Water Development Board, Austin, Texas, USA (April 2009).
- Anderson, R. Y., Dean, W. E. Jr., Kirkland, D. W. et al. 1972. Permian Castile varved evaporite sequence, west Texas and New Mexico. *Geological Society of America Bulletin* **83**(1): 59-86.
- Appelo, C.A.J., and Postma, D. 2005. *Geochemistry, Groundwater and Pollution*, 2nd Edition, 647 p.
- Ashworth, J. B. and Hopkins, J. 1995. Aquifers of Texas. Report 345, Texas Water Development Board, Austin, Texas, USA.
- Bandilla, K.W., Kraemer, S.R., Birkholzer, J.T, 2012. Using semi-analytic solutions to approximate the area of potential impact for carbon dioxide injection. *International Journal of Greenhouse Gas Control* **8**: 196-204.
- Beauheim, R. L. and Roberts, R. M. 2002. Hydrology and hydraulic properties of a bedded evaporite formation. *Journal of Hydrology* **259**(1-4): 66-88.
- Bennion, D. B, 2006. Supercritical CO₂ and H₂S—Brine Drainage and Imbibition Relative Permeability Relationships for Intergranular Sandstone and Carbonate Formations. Society of Petroleum Engineers Paper 99326, 13 p.
- Birkholzer, J.T., Nicot, J.P., Oldenburg, C.M., Zhou, Q., Kraemer, S., Bandilla, K., 2011. Brine flow up a well caused by pressure perturbation from geologic carbon sequestration: Static and dynamic evaluations. *International Journal of Greenhouse Gas Control* **5**: 850-861.
- Boghici, R. 1999. Changes in Groundwater Conditions in Parts of Trans-Pecos Texas, 1988-1998. Report 348, Texas Water Development Board, Austin, Texas, USA.
- Boyd, D. W. 1958. Permian Sedimentary Facies, Central Guadalupe Mountains. *New Mexico Bureau of Mines and Mineral Resources, Bulletin* 49, 100 p.
- Bradley, R. G. and Kalaswad, S. 2001. The Dockum Aquifer in West Texas. In *Aquifers of West Texas*, ed. R. E. Mace, W. F. Mullican, and E. S. Angle: 167-174.
- Collins, D. A., Nghiem, L. X., Li, Y-K. et al. 1992. An Efficient Approach to Adaptive-Implicit Compositional Simulation with an Equation of State. *SPE Res. Eng* **7**: 259-264.
- Corey, A. T. 1954. The interrelation between gas and oil relative permeabilities. *Producers Monthly* **19**: 38-41.
- Dean, W. E., Kirkland, D. W., Denison, R. E. 2000. Parent brine of the castile evaporites (Upper Permian). Texas and New Mexico. *USGS Staff--Published Research* 307.
- Eifler, G. K. Jr. 1975. *Geologic Atlas of Texas, Pecos Sheet*. Austin, Texas: The University of Texas Bureau of Economic Geology.

EPA 816-R-13-005. 2013. Geologic Sequestration of Carbon Dioxide – Underground Injection Control (UIC) Program Class VI Well Area of Review Evaluation and Corrective Action Guidance. Washington, DC; US Environmental Protection Agency, Office of Water.

Espinoza, D. N. and Santamarina, J. C. 2017. CO₂ breakthrough—Caprock sealing efficiency and integrity for carbon geological storage. *International Journal of Greenhouse Gas Control* **66**: 218-229.

Ewing, T. E., Love, D. W., Hawley, J. W. et al. 1993. Erosional margins and patterns of subsidence in the late Paleozoic west Texas basin and adjoining basins of west Texas and New Mexico. In *Carlsbad Region, New Mexico and West Texas: New Mexico Geological Society, 44th Annual Field Conference* 155-166.

Ewing, J. E., Jones, T. L., Yan, T. et al. 2008. Groundwater availability model for the Dockum Aquifer. Final Report, Texas Water Development Board, Austin, Texas, USA.

Ewing, T. E., Barnes, M. A., and Denison, R. E. 2019. Proterozoic foundations of the Permian Basin, West Texas and Southeastern New Mexico—A Review. In *Anatomy of a Paleozoic Basin: The Permian Basin, USA* (Vol. 1), ed. S. C. Ruppel. Austin, Texas: The University of Texas Bureau of Economic Geology, Report of Investigations 285. *AAPG Memoir* **118**: 43-61.

Fairhurst, B., Ewing, T. and Lindsay, B., 2021. West Texas (Permian) Super Basin, United States: Tectonics, structural development, sedimentation, petroleum systems, and hydrocarbon reserves. *AAPG Bulletin*, **105**(6): 1099-1147.

Fischer, A. G. and Sarnthein, M. 1988. Airborne silts and dune-derived sands in the Permian of the Delaware Basin. *Journal of Sedimentary Petrology* **58**(4): 637-643.

Fjaer, E., Hole, R. M., Horsrud, P. et al. 2008. *Petroleum Related Rock Mechanics*, second edition. Amsterdam, the Netherlands: Elsevier Science.

Freeze, R. A., and Cherry, J. A.: Groundwater, Prentice-Hall. Inc., Englewood Cliffs, N.J., 1979.

Gardner, M. H., Borer, J. M., Melick, J. J. et al. 2003. Stratigraphic process-response model for submarine channels and related features from studies of Permian Brushy Canyon outcrops, West Texas. *Marine and Petroleum Geology* **20**(6): 757-787.

George, P. G., Mace, R. E., and Petrossian, R. 2011. Aquifers of Texas. Report 380, Texas Water Development Board, Austin, Texas, USA.

Ghomian, Y. 2008. *Reservoir Simulation Studies for Coupled CO₂ Sequestration and Enhanced Oil Recovery*. PhD dissertation, University of Texas, Austin, Texas (May 2008).

Greene, J., Newsham, K., Pavlovic, M., Jerath, K., Cox, C., McAllen, M. 2021. Workflow for Determining Relative Permeability Behavior in Low Permeability Media Using MICP Drainage-Imbibition Measurements. URTEC Paper 5220, 27 p.

Hangx, S., Spiers, C. and Peach, C. 2009. The mechanical behavior of anhydrite and the effect of CO₂ injection. *Energy Procedia* **1**: 3485-3492
Harvey, A. H. 1996. Semiempirical Correlation for Henry's Constants over Large Temperature Ranges. *AIChE Journal* **42**(5): 1491-1494.

He, Y., Kerans, C., Zeng, H., Janson, X. and Scott, S. 2019. Improving Three-Dimensional High-Order Seismic-Stratigraphic Interpretation for Reservoir Model Construction: An example of geostatistical and

Plan revision number: 3
Plan revision date: 07/30/2024

seismic forward modeling of Permian San Andres shelf-Grayburg platform mixed clastic-carbonate strata. *AAPG Bulletin* **103**(8): 1839-1887.

Henry, C. D. and Price, J. G. 1986. Early basin and range development in Trans-Pecos Texas and adjacent Chihuahua: Magmatism and orientation, timing, and style of extension. *Journal of Geophysical Research: Solid Earth* **91**(B6): 6213-6224.

Hills, J. M. 1984. Sedimentation, tectonism, and hydrocarbon generation in Delaware Basin, west Texas and southeastern New Mexico: *AAPG Bulletin* **68**(3): 250-267.

Holubnyak, Y., Watney, W., Rush, J., and Fazelalavi, F. 2014. Reservoir Engineering Aspects of Pilot Scale CO₂ EOR Project in Upper Mississippian Formation at Wellington Field, in Southern Kansas. *Energy Procedia* **63**: 7732-7739.

Horne, E. A., Hennings, P. H., and Zahm, C. K. 2021. Basement-rooted faults of the Delaware Basin and Central Basin Platform, Permian Basin, West Texas and southeastern New Mexico. In *The Geologic Basement of Texas: A Volume in Honor of Peter Flawn*, eds. O. A. Callahan and P. Eichhubl, Austin, Texas: The University of Texas Bureau of Economic Geology.

Hosseini, S. A., Lashgari, H., Choi, J. W., Nicot, J. P., Lu, J., and Hovorka, S. 2012. Static and Dynamic Reservoir Modeling for Geological CO₂ Sequestration at Cranfield, Mississippi, U.S.A. *International Journal of Greenhouse Gas Control* **18**: 449-462.

Jaeger, J. C. and Cook, N. G. W. 2007. *Fundamentals of Rock Mechanics*, fourth edition. London, UK: Chapman and Hall.

Janson, X. and Hairabian, J. 2016. Guadalupian Stratigraphy and Slope Systems in the Southern Delaware Basin, Glass Mountains. Austin, Texas: The University of Texas Bureau of Economic Geology, RCRL Guidebook, 138 p.

Jia, W., Xiao, T., Wu, Z., Dai, Z., McPherson, B., 2021. Impact of Mineral Reactive Surface Area on Forecasting Geological Carbon Sequestration in a CO₂-EOR Field. *Energies* **14**: 1608.

Kendall, A. C. and Harwood, G. M. 1989. Shallow-water gypsum in Castile Formation—Significance and implications. *AAPG Bulletin* **73**(CONF-890404-).

Kerans, C., and Fitchen, W. M. 1995. Sequence hierarchy and facies architecture of a carbonate-ramp system: San Andres Formation of Algerita Escarpment and western Guadalupe Mountains, west Texas and New Mexico. Austin, Texas: The University of Texas Bureau of Economic Geology, *Report of Investigations* 235, 86 p.

Kerans, C., and Tinker, S.W. 1997. Sequence Stratigraphy and Characterization of Carbonate Reservoirs. SEPM Short Course 40.

Kestin, J., Khalifa, H. E., and Correia, R. J. 1981. *J. Phys. Chem. Ref. Data* **10**(1): 71.

King, P. B. 1937. Geology of the Marathon Region, Texas. Professional Paper 187, US Geological Survey, Washington, DC.

King, P. B. 1948. Geology of the Southern Guadalupe Mountains, Texas. Professional Paper 215, US Geological Survey, Washington, DC, USA.

Krupka, K.M., Cantrell, K.J., McGrail, B.P. 2010. Thermodynamic Data for Geochemical Modeling of Carbonate Reactions Associated with CO₂ Sequestration - Literature Review. U.S. Department of Energy, Pacific Northwest National Laboratory. 135 p.

Kutchko, B.G., Strazisar, B.R., Huerta, N., Lowry, G.V., Dzombak, D.A., Thaulow, N., 2009. CO₂ Reaction with Hydrated Class H Well Cement under Geologic Sequestration Conditions: Effects of Flyash Admixtures. *Environmental Science & Technology* **43** (10), 3947-3952.

Lehman, T. M. 1994. The saga of the Dockum Group and the case of the Texas/New Mexico boundary fault. New Mexico Bureau of Mines and Mineral Resources, *Bulletin 150*, 37-51.

Lucia, F. J. 1983. Petrophysical parameters estimated from visual description of carbonate rocks: a field classification of carbonate pore space: *Journal of Petroleum Technology*, March, 626-637.

Lucia, F. J. 1995. Rock-fabric/petrophysical classification of carbonate pore space for reservoir characterization. *AAPG Bulletin* **79**(9): 1275-1300.

Lucia, F. J. 2007. *Carbonate Reservoir Characterization*, second edition. New York, New York, USA: Springer-Verlag.

Lucia, F. J. and Major, R. P. 1994. *Porosity Evolution through Hypersaline Reflux Dolomitization*. New York, New York, USA: John Wiley & Sons, 325-341.

Lun, L., Krishnamurthy, P., Kohli, K., Wattenbarger, R.C., 2023. Developing Consistent Relative Permeability and Capillary Pressure Models for Reservoir Simulation of CCS Projects. SPE Paper 216722-MS. 14 p.

Mace, R. E., Davidson, P. S. C., Angle, E. S. et al. 2006. *Aquifers of West Texas* (356: 1-281). Austin, Texas: Texas Water Development Board.

Major, R. P., Vander Stoep, G. W., and Holtz, M. H. 1990. Delineation of Unrecovered Mobile Oil in a Mature Dolomite Reservoir: East Penwell San Andres Unit, University Lands, West Texas. Austin, Texas: The University of Texas Bureau of Economic Geology, *Report of Investigations No. 194*, 52 p.

Matchus, E. J. and Jones, T. S. 1984. East-West Cross Section Through the Permian Basin of West Texas. *Publication No. 84-79*, West Texas Geological Society, Midland, Texas.

Mathis, R. L. and Sears, S. O. 1984. Effect of CO₂ Flooding on Dolomite Reservoir Rock, Denver Unit, Wasson (San Andres) Field, TX. Paper presented at the SPE Annual Technical Conference and Exhibition, Houston, Texas, USA, 16-19 September. SPE-13132-MS. <https://doi.org/10.2118/13132-MS>.

McBride, E. 1989. Stratigraphy and sedimentary history of pre-Permian Paleozoic rocks of the Marathon uplift. In *The Appalachian-Ouachita Orogen in the United States*, eds. R. D. Hatcher, Jr., W. A. Thomas, and G. W. Viele. Geological Society of America, *The Geology of North America F-2*: 603-620.

Meissner, F. F. 1972. Cyclic sedimentation in Middle Permian strata of the Permian Basin, West Texas and New Mexico. In *Cyclic Sedimentation in the Permian Basin*, second edition, eds. J. G. Elam and S. Chuber. *Publication 72-60*: 203-232, West Texas Geological Society, Midland, Texas.

Meyer, J. E., Wise, M. R. and Kalaswad, S. 2012. Pecos Valley Aquifer, West Texas: structure and brackish groundwater. *Report 382*, 1-92, Texas Water Development Board, Austin, Texas, USA.

Meyer, J. E. 2020. *Brackish Resources Aquifer Characterization System Database Data Dictionary. Open File Report 12-02*, fifth edition. Texas Water Development Board, Austin, Texas, USA.

Mohamed, I.M., He, J., Nasr-El-Din, H.A. 2011. Carbon Dioxide Sequestration in Dolomite Rock, IPTC 14924. 26 p.

Mosher, S., Hoh, A. M., Zumbro, J. A. et al. 2004. Tectonic evolution of the eastern Llano Uplift, central Texas: A Record of Grenville Orogenesis Along the Southern Laurentian Margin. *Geological Association of America Memoir* **197**: 783-798.

Nghiem, L. X. and Li, Y-K. 1989. Phase-Equilibrium Calculations for Reservoir Engineering and Compositional Simulation. Paper presented at the Second International Forum on Reservoir Simulation, Alpbach, Austria, 4-8 September.

Nicot, J., Oldenburg, C.M., Bryant, S.L., Hovorka, S.D., 2009. Pressure perturbations from geologic carbon sequestration: Area-of-review boundaries and borehole leakage driving forces. *Energy Procedia* **1**: 47-54.

Oldenburg, C.M., Cihan, A., Zhou, Q. Fairweather, S., Spangler, L.H., 2014. Delineating area of review in a system with pre-injection relative overpressure. *Energy Procedia* **63**, 3715-3722.

Palandri, J.L. and Kharaka, Y.K. 2004. A Compilation of rate parameters of water-mineral interaction kinetics for application to geochemical modeling. *U.S. Geological Survey Open File Report 2004-1068*: 70 p.

Palermo D., Aigner, T., Nardon, S., and Blendinger, W. 2010. Three-Dimensional Facies Modeling of Carbonate Sand Bodies: Outcrop Analog Study in an Epicontinental Basin (Triassic, Southwest Germany). *AAPG Bulletin* **94** (4): 475-512.

Parkhurst, D.L. and Appelo, C.A.J., 2013. Description of Input and Examples for PHREEQC Version 3-- A Computer Program for Speciation, Batch-Reaction, One-Dimensional Transport, and Inverse Geochemical Calculations. *Groundwater Book 6, Modeling Techniques*: 519 p.

Pedersen, K. S., Fredenslund, A., Christensen, P. L. et al. 1984. Viscosity of Crude Oils. *Chem. Eng. Sci.* **39**(6): 1011-1016.

Peng, D-Y. and Robinson, D. B. 1976. A New Two-Constant Equation of State. *Ind. Eng. Chem. Fundamentals* **15**: 59-64.

Reed, T. and Strickler, D. 1990. Structural geology and petroleum exploration of the Marathon thrust belt, West Texas. In Proceedings Marathon Thrust Belt: Structure, Stratigraphy, and Hydrocarbon Potential. In *West Texas Geological Society and Permian Basin Section SEPM Field Seminar*, May 10-12, ed. L. Higgins, 3-64.

Reid, R. C., Prausnitz, J. M., and Sherwood, T. K. 1977. *The Properties of Gases and Liquids*, third edition, New York, New York, USA: McGraw-Hill.

Ross, C. A. 1986. Paleozoic evolution of southern margin of Permian basin. *Geological Society of America Bulletin* **97**(5): 536-554.

Ruppel, S. and Bebout, D. 1996. Effects of stratal architecture and diagenesis on reservoir development in the Grayburg Formation: South Cowden field, Ector County, Texas. In *Annual Report for the Period 1*

Plan revision number: 3
Plan revision date: 07/30/2024

October 1994 to 30 September 1995 (DOE/BC/14895-10), University of Texas Bureau of Economic Geology, Austin, Texas, USA.

Rush, J. W. and Rankey, E. C. 2017. Geostatistical Facies Modeling Trends for Oolitic Tidal Sand Shoals. *AAPG Bulletin* 101 (8): 1341-1379.

Sakurai, S., Ramakrishnan, T. S., Boyd, A. et al. 2006. Monitoring Saturation Changes for CO₂ Sequestration: Petrophysical Support for the Frio Brine Pilot Experiment. *Petrophysics* 47 (6): 483-496.

Scotese, C. R. and McKerrow, W. S. 1990. Revised World Maps and Introduction. In *Paleozoic Paleogeography and Biogeography*, eds. W. S. McKerrow and C. R. Scotese. *The Geological Society of London Memoir* 12: 1-21.

Sharqawy, M.H., Lienhard, J.H., Zubair, S.M., 2010. Thermophysical properties of seawater: a review of existing correlations and data. *Desalination and Water Treatment* 16 (4): 354-380

Siemers, W. T., Howard, J. J., and Gerard, M. G. 1996. Multidisciplinary study to optimize reservoir management of the North Penwell (San Andres) unit, Ector County Texas. *AAPG Bulletin* 79 (9).

Silver, B. A. and Todd, R. G. 1969. Permian cyclic strata, northern Midland and Delaware basins, west Texas and southeastern New Mexico. *AAPG Bulletin* 53 (11): 2223-2251.

Society of Petroleum Engineers, et al. Petroleum Resources Management System, Revised June 2018, 57 pp.

Soto-Kerans, G. M., Stockli, D. F., Janson, X. et al. 2020. Orogen proximal sedimentation in the Permian foreland basin. *Geosphere* 16(2): 567-593.

Thomas, G. W. and Thurnau, D. H. 1983. Reservoir Simulation Using an Adaptive-Implicit Method. *SPE Journal* 23(10): 759-768.

Thornhill, J. T., Short, T. E., and Silka, L. 1982. Application of the Area of Review Concept. *Ground Water* 20(1): 32-38.

Truesdell, A.H., and Jones, B.F., 1974, WATEQ, A computer program for calculating chemical equilibria of natural waters, *Journal of Research U.S. Geological Survey*, 2 (2): 233-248.

Ward, R. F., Kendall, C. G., and Harris, P. M. 1986. Upper Permian (Guadalupian) Facies and Their Association with Hydrocarbons--Permian Basin, West Texas and New Mexico.. *AAPG Bulletin* 70: 239-262.

White, D. E. 1971. Water Resources of Ward County, Texas. Report No. 125, Texas Water Development Board, Austin, Texas, USA.

Yang, K. M. and Dorobek, S. L. 1995. The Permian Basin of West Texas and New Mexico: Tectonic History of a "Composite" Foreland Basin and its Effects on Stratigraphic Development. In *Stratigraphic Evolution of Foreland Basins*, SEPM Special Publication No. 52: 149-174.

Zhang, Y., Hu, B., Teng, Y., Tu, K., and Zhu, C., 2019, A library of BASIC scripts of reaction rates for geochemical modeling using PHREEQC. *Computers and Geosciences*, (133)

Zoback, M.D. 2010. *Reservoir Geomechanics*. New York, New York, USA: Cambridge University Press.

Plan revision number: 3
Plan revision date: 07/30/2024

Websites

National Geographic Society. 2013. ArcGIS REST Services Directory,
http://services.arcgisonline.com/arcgis/rest/services/USA_Topo_Maps/MapServer
(accessed 15 December 2021).

Texas Railroad Commission (TRRC). 2021. Oil and Gas Completions Database Query,
<http://webapps.rrc.state.tx.us/CMPL/publicSearchAction.do?formData.methodHndlr.inputValue=init&formData.headerTabSelected=home&formData.pageForwardHndlr.inputValue=home>
(accessed 15 December 2021).

Texas Water Development Board (TWDB). 2021. Major Texas Aquifers,
<https://www.twdb.texas.gov/groundwater/aquifer/major.asp>
(accessed 1 December 2021).

Texas Water Development Board (TWDB). 2021. Minor Texas Aquifers,
<https://www.twdb.texas.gov/groundwater/aquifer/minor.asp>
(accessed 1 December 2021).

Texas Water Development Board (TWDB). 2021. Interactive groundwater viewer,
<https://www3.twdb.texas.gov/apps/WaterDataInteractive/GroundWaterDataViewer>
(accessed 15 December 2021).

United States Geological Survey (USGS), Bureau of Economic Geology (BEG). 1992. Antlers Sand Geology Fact Sheet,
<https://mrdata.usgs.gov/geology/state/sgmc-unit.php?unit=TXKa%3B0>
(accessed 28 December 2021).

United States Geological Survey (USGS), Bureau of Economic Geology (BEG). 1992. Dockum Group Geology Fact Sheet,
<https://mrdata.usgs.gov/geology/state/sgmc-unit.php?unit=TXTRd%3B0>
(accessed 28 December 2021).

United States Geological Survey (USGS), University of Texas - Bureau of Economic Geology (UTBEG), Texas Natural Resources Information System (TNRIS). 2007. Geologic Database of Texas,
<https://txpub.usgs.gov/txgeology/>
(accessed 28 December 2021).

United States Geological Survey (USGS). 2018. Long-Term National Seismic Hazard Map,
<https://www.usgs.gov/media/images/2018-long-term-national-seismic-hazard-map>
(accessed 7 May 2022).

OPERATIONS PLAN, APPENDIX A: AOR BASELINE

Brown Pelican CO₂ Sequestration Project

1.0 Facility Information	2
2.0 Introduction.....	2
3.0 Updates to Operational Limits	3
4.0 Updates to Modelling of the AoR.....	4
4.1 No updates to geocellular model inputs [16 TAC 5.206(g)(4)].....	4
4.2 Modeling the CO ₂ plume and pressure front at site closure [16 TAC 5.203(d)(1)(A)].....	5
5.0 Conclusions.....	8

1.0 Facility Information

Facility name: Brown Pelican CO₂ Sequestration Project
BRP CCS1, CCS2 and CCS3 Wells

Facility contact: [REDACTED]
[REDACTED]
[REDACTED]

Well location: Penwell, Texas

BRP CCS1	31.76481926	-102.72891895
BRP CCS2	31.76994887	-102.73320589
BRP CCS3	31.76024766	-102.71013484

2.0 Introduction

This report describes updated operational limits for the BRP CCS1, BRP CCS2, and BRP CCS3 UIC Class VI wells based on data collected during construction of these wells. Additionally, this report describes a comparison in the Area of Review (AoR) for the Brown Pelican CO₂ Sequestration Project (BRP Project or Project) that was modeled using data collected in the Shoe Bar 1 and Shoe Bar 1AZ stratigraphic test wells compared to data collected in the BRP CCS1, BRP CCS2, and BRP CCS3 injection wells. OLCV concludes that the updated operational limits of the UIC Class VI wells will not result in a material change to the areal extent of AoR. The Injection Well Operating Conditions (Attachment E of Class VI SIP Permit No. 55294) and the Testing and Monitoring Plan (Attachment F of Class VI SIP Permit No. 55294) are updated in accordance with the revised AoR. No other plan updates are required.

OLCV initially obtained information on rock strength during logging and testing of the Shoe Bar 1 and Shoe Bar 1AZ stratigraphic test wells. Pursuant to 16 TAC 5.206(d)(1)(B)(vii), OLCV later obtained updated geomechanical information during logging and testing of the BRP CCS1, BRP CCS2, and BRP CCS3 UIC Class VI wells. The updated geomechanical information obtained during logging and testing provides more accurate information on subsurface conditions at the sites of the three injection wells. Based on these new data, OLCV updated the determination of fracture pressure and the resultant operational limits for each of the wells.

The updated operational limits result in no material change to the AoR, that is defined by the critical pressure threshold at which an increase in pore pressure is high enough to overcome the hydraulic head of the fluid in a hypothetical wellbore and enter the Underground Source of Drinking Water (USDW). At the BRP Project site, the AoR represents the maximum extent of pressure from the three injection wells at the end of 12 years of CO₂ injection and the maximum extent of the CO₂ plume 50 years after injection ceases.

3.0 Updates to Operational Limits

OLCV used the fracture propagation pressure estimates obtained from mini-frac tests in the BRP CCS1, BRP CCS2, and BRP CCS3 to calculate a maximum bottomhole injection pressure that is 90% of fracture opening pressure. A calculation of bottomhole pressure is shown in Attachment E of Class VI SIP Permit No. 55294 for BRP CCS1, BRP CCS2, and BRP CCS3.

Well injectivity is related to bottomhole pressure; therefore, the injection rate in BRP CCS1 and BRP CCS3 increased in response to an increase in bottomhole pressure based on the mini-frac tests. To optimize CO₂ distribution among the three wells, the injection rate in BRP CCS2 decreased. In addition, the injection rate is dependent on the capture and transport capacity from the Stratos Direct Air Capture facility. OLCV modified the maximum and average injection rate according to the new bottomhole pressure calculations. Updated operational limits are presented in Table 1.

Surface wellhead injection pressure increased as a result of increased bottomhole pressure. Surface facilities and flowlines can safely accommodate the increase in surface wellhead pressure, which is well within the technical and operational parameters of that equipment. Wellhead pressure is estimated from bottom-hole pressure using a physics-based model that accounts for changes in injectant conditions in the well. Bottom-hole injection pressure reflects the wellhead injection pressure including the cumulative pressure changes that occur along the wellbore.

Table 1. Proposed operational values.

Parameter/ Condition	BRP CCS1: Original Permit Value	BRP CCS2: Original Permit Value	BRP CCS3: Original Permit Value	BRP CCS1: Updated Permit Value	BRP CCS2: Updated Permit Value	BRP CCS3: Updated Permit Value	Units
Daily maximum injection mass	600	1,500	600	1,040	1,196	676	Metric tons per day
Daily average injection mass	450	1,112	450	572	1,040	468	Metric tons per day
Daily maximum injection rate	8.2	25	9.0	20	23	13	Million standard cubic feet per day
Daily average injection rate	7.9	21.9	8.1	11	20	9	Million standard cubic feet per day
Total mass	1.83	4.87	1.77	2.50	4.55	2.05	Million metric tons
Maximum injection mass	166,000	481,000	166,000	379,466	436,386	246,653	Metric tons per year

Parameter/ Condition	BRP CCS1: Original Permit Value	BRP CCS2: Original Permit Value	BRP CCS3: Original Permit Value	BRP CCS1: Updated Permit Value	BRP CCS2: Updated Permit Value	BRP CCS3: Updated Permit Value	Units
Average injection mass	153,000	406,000	153,000	208,706	379,466	170,760	Metric tons per year
Maximum surface wellhead injection pressure	1,100	1,800	1,100	2,342	3,202	1,568	psig
Maximum bottomhole injection pressure	2,625.30	3,391.80	2,625.30	3,362	4,111	2,830	psig
Minimum annulus pressure	100	100	100	100	100	100	psig
Minimum annulus pressure/ tubing differential	100	100	100	100	100	100	psig

4.0 Updates to Modelling of the AoR

4.1 No updates to geocellular model inputs [16 TAC 5.206(g)(4)]

OLCV reviewed the data obtained during logging and testing of the BRP CCS1, BRP CCS2, and BRP CCS3 and concludes that no updates are required to the geocellular model for the BRP Project. OLCV observed little variation in the BRP CCS1, BRP CCS2, and BRP CCS3 wells compared with the well and seismic data available during construction of the geocellular and dynamic simulation models presented in the Area of Review and Corrective Action Plan, Attachment A of Class VI SIP Permit No. 55294. OLCV determined the following:

- No changes to the geologic structure or hydrogeologic properties of the Injection Zone or Upper or Lower Confining Zones [16 TAC 5.206(d)(1)(B)(ii)].
- No changes to the compatibility of the CO₂ injectate stream with fluids in the Injection Zone or minerals in the Injection or Confining Zones [16 TAC 5.206(d)(1)(B)(iii)].
- No changes resulting from the formation testing program [16 TAC 5.206(d)(1)(B)(iv)].

- Corrective action was executed, as planned, and no additional wells requiring corrective action were identified [16 TAC 5.206(d)(1)(B)(vi)].
- All available logging and testing results have been considered [16 TAC 5.206(d)(1)(B)(vii)].

4.2 Modeling the CO₂ plume and pressure front at site closure [16 TAC 5.203(d)(1)(A)]

OLCV conducted a dynamic simulation using the proposed bottomhole pressure and average injection rates shown in Table 1. Modeling indicates that the area and shape of the updated AoR is not materially different from the previously modeled AoR – in fact, the updated AoR is slightly smaller than the permitted AoR. The area of the permitted AoR is approximately 5.5 square miles, and the area of the updated AoR is approximately 4.8 square miles. Figure 1 shows the comparison between the permitted AoR, delineated by a light yellow continuous line, and the updated AoR, delineated by a dark yellow dashed line. Potential leakage pathways identified in the updated AoR are the same as those identified in the permitted AoR – there are no new potential leakage pathways in the updated AoR. Corrective action on three legacy wells in the permitted AoR was performed in 2025. The updated AoR does not encompass any additional wells or any wells requiring corrective action.

The similarity in the as-permitted AoR compared to the updated AoR is the result of the modeled vertical distribution of CO₂ within the permitted Injection Zone. Figure 2 shows a cross-section comparison between the permitted and updated results at the end of the injection period. The cross-section comparison shows a small increase in CO₂ plume size in the G1/G4 sub-zones and a small reduction of the CO₂ plume size in the Holt sub-zone. Because the G1/G4 and Holt sub-zones are vertically stacked, the overall impact on the AoR as a result of the updated injection rates is negligible.

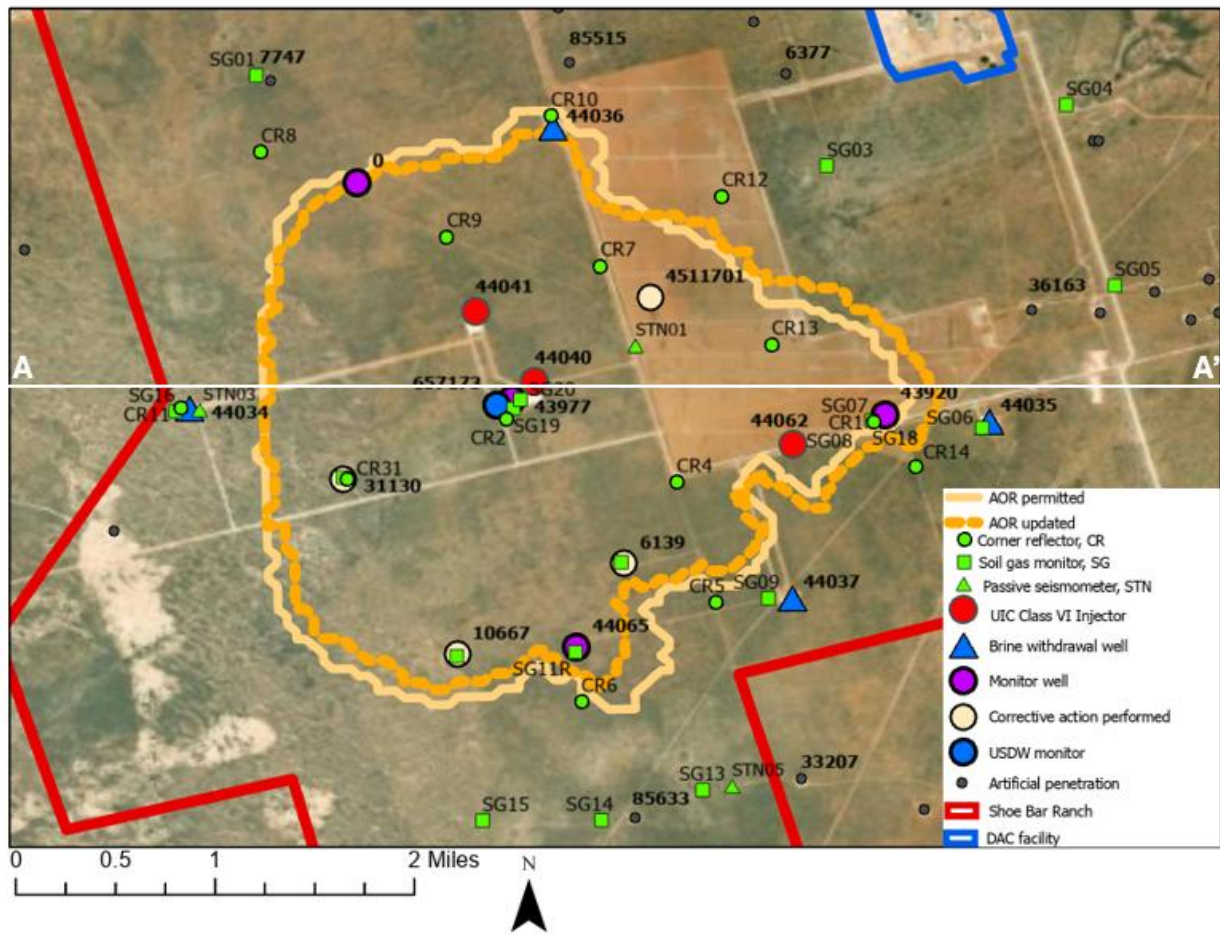

Figure 1: Map view showing Area of Review (AoR) as permitted (solid gold line) vs. updated AoR (dashed dark gold line). A-A' represents the West – East cross-section shown in Figure 2.

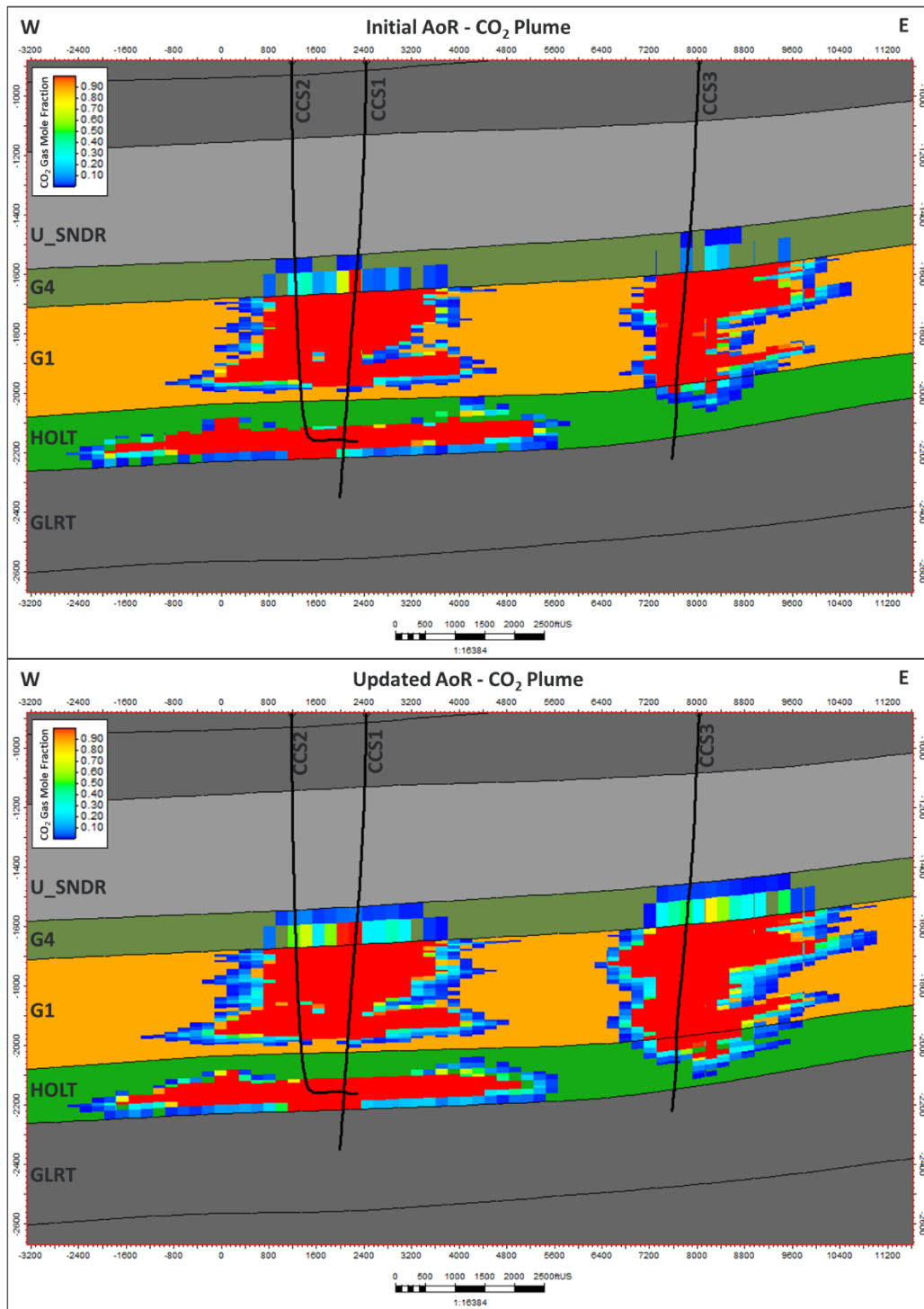

Figure 2: West (left) to East (right) cross-section through the geocellular model. The Lower San Andres Formation is the permitted Injection Zone. The Lower San Andres Formation is sub-divided into the G4, G1, and Holt sub-zones. The images show the modeled maximum lateral CO₂ plume extent, which occurs at the

end of the injection period. The upper panel shows the permitted AoR. The lower panel shows the updated AoR based on updated injection rates and pressures.

5.0 Conclusions

OLCV evaluated mini-frac test data obtained during construction of the BRP CCS1, BRP CCS2, and BRP CCS3 UIC Class VI wells. The permitted operational parameters for the BRP Project were based on data from the Shoe Bar 1 and Shoe Bar 1AZ stratigraphic test wells. Based on new data from the drilled and constructed UIC Class VI wells, OLCV updated the maximum bottomhole pressure limit for these wells. OLCV then determined the maximum surface wellhead pressures using the updated maximum bottomhole pressures. Accordingly, OLCV updated the Injection Well Operating Conditions (Attachment E of Class VI SIP Permit No. 55294) to reflect the updated CO₂ injection rates and pressures.

Additionally, OLCV performed a dynamic simulation using updated operating conditions. The resulting updated AoR does not differ materially from the permitted AoR. As stated above, the updated AoR is actually slightly smaller than the permitted AoR. Increased CO₂ injection in BRP CCS1 and BRP CCS3 is balanced by reduced CO₂ injection in the BRP CCS2, resulting in a similar AoR. As a result, OLCV determined that, except as set forth above, no changes to any other Attachments to Class VI SIP Permit No. 55294 are needed.

B. WELL CONSTRUCTION PLAN

INJECTION WELL CONSTRUCTION PLAN
40 CFR §146.82(a)(11) and (12), §146.86, §146.87, and §146.88 (a), (b), (c), and (e)

Brown Pelican CO₂ Sequestration Project

1.0 Facility Information.....2
2.0 Overview2
3.0 Design Parameters and Specifications.....3
4.0 Well Design4
 4.1 BRP CCS14
 4.2 BRP CCS217
 4.3 BRP CCS328
 4.4 Material Selection.....40
 4.5 Cement Program40
 4.6. Mud Program.....41
5.0 Data Acquisition and Testing Plan Summary42
6.0 Demonstration of Mechanical Integrity and Baseline for Monitoring47
7.0 Blowout Preventer and Wellhead Requirements.....47
 7.1 Blowout Preventer Equipment (BOPE).....48
 7.2 Choke Manifolds and Kill Line48
 7.3 Closing Units49
 7.4 Pressure Testing.....49
 7.5 Wellhead Schematic50

1.0 Facility Information

Facility name: Brown Pelican CO₂ Sequestration Project
BRP CCS1, CCS2 and CCS3 Wells

Facility contact: [REDACTED]
[REDACTED]
[REDACTED]

Well location: Penwell, Texas

BRP CCS1	31.76481926	-102.72891895
BRP CCS2	31.76994887	-102.73320589
BRP CCS3	31.76024766	-102.71013484

2.0 Overview

Oxy Low Carbon Ventures, LLC (OLCV) constructed UIC Class VI CO₂ injection wells for the Brown Pelican CO₂ Sequestration Project (BRP Project or Project) according to the procedures in this document. The matter of construction details is relevant to the requirements of Environmental Protection Agency (EPA) document 40 CFR Subpart H – Criteria and Standards Applicable to Class VI Wells. The main topics covered in this attachment are special construction requirements, open hole diameters and intervals, casing specifications, tubing specifications, data acquisition and testing plan, and demonstration of mechanical integrity.

The BRP CCS1, BRP CCS2, and BRP CCS3 wells were constructed with the highest standards and best practices for drilling and well construction. The design and materials were selected to ensure mechanical integrity and to optimize the operation during the life of the Project.

3.0 Design Parameters and Specifications

The UIC Class VI wells were designed to maximize the rate of injection while maintaining the bottomhole pressure below 90% of the fracture gradient. The selected design provides enough clearance to deploy the pressure and temperature gauges on tubing and install a fiber optic cable on the long string casing to ensure continuous surveillance of external integrity and conformance.

Design parameters that will be employed during the life of the well are shown in Table 1, and CO₂ specifications for the Project are shown in Table 2. A nodal analysis was used to perform sensitivities on the tubing size, rate of erosion, and potential movement of the tubulars. The nodal analysis results, operating parameters, and CO₂ specifications were used in selecting materials to construct the well.

Table 1—Design Parameters

Parameter	Value or Range
Injection rate (MTPD)	417-1319
Tubing pressure (psi)	1,000 to 1,800
Annular surface pressure (psi)	0 to 400
Surface temperature (°F)	60 to 90
Bottomhole temperature (°F)	120

Note:

Annular surface pressure between the tubing and long string will be kept between 0 and 400 psi to monitor changes during injection. It is not recommended to apply the maximum injection pressure to the annulus between the tubing and the long string casing to avoid unnecessary stress on the cement sheath, which could lead to a micro-annulus or microfractures.

Table 2—Specification of CO₂ Injectate

Component	Specification
CO ₂ content	>95 mol%
Water	<30 lbm/MMscf
Nitrogen	<4 mol%
Sulphur	<35 ppm by weight
Oxygen	<5 mol%
Glycol	<0.3 gal/MMscf
Carbon Monoxide	<4,250 ppm by weight
NO _x	<6 ppm by weight
SO _x	<1 ppm by weight
Particulates (CaCO ₃)	<1 ppm by weight
Argon	<1 mol%
Surface pressure	>1,600 psig
Surface temperature	>65°F and <120°F

4.0 Well Design

OLCV constructed three UIC Class VI CO₂ injector wells: BRP CCS1, BRP CCS2, and BRP CCS3 for the Project. The locations and orientations of those wells are shown in Figure 1 below.

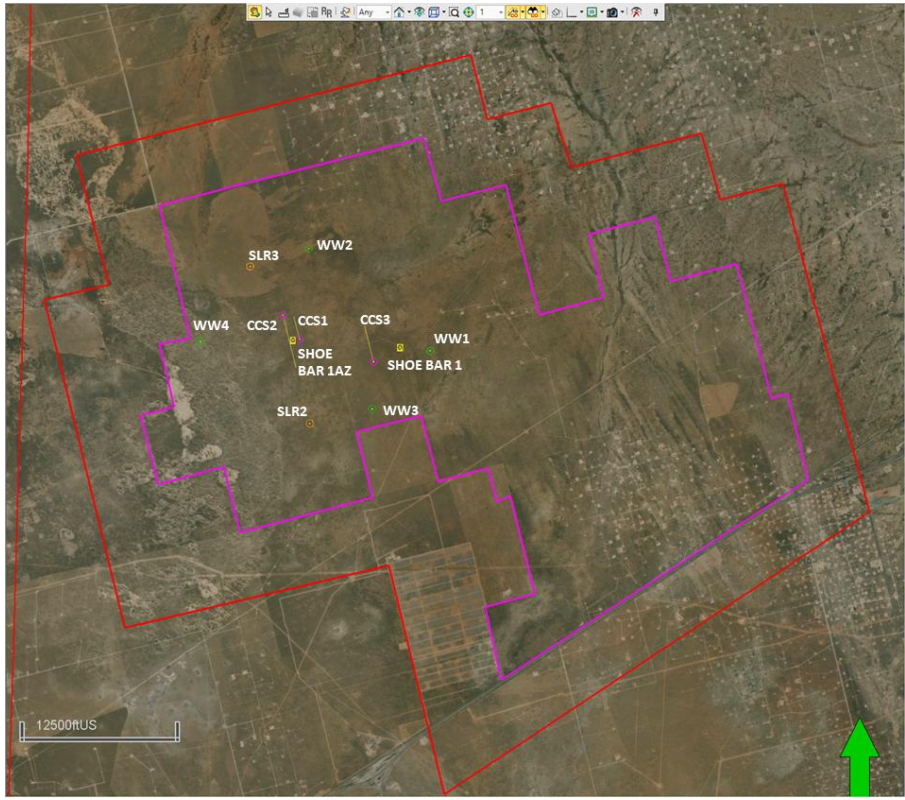

Figure 1—BRP CCS1, BRP CCS2 and BRP CCS3 Well Locations

4.1 BRP CCS1

4.1.1 Design for BRP CCS1

The BRP CCS1 well design includes three main casing sections: 1) surface casing to cover the USDW and provide integrity while drilling to the Injection Zone, 2) intermediate section, and 3) a long string section to acquire formation data and isolate the target formation while running the upper completion equipment. Figure 2 presents wellbore trajectory of BRP CCS1 and Figure 3 is BRP CCS1 as-drilled wellbore schematic

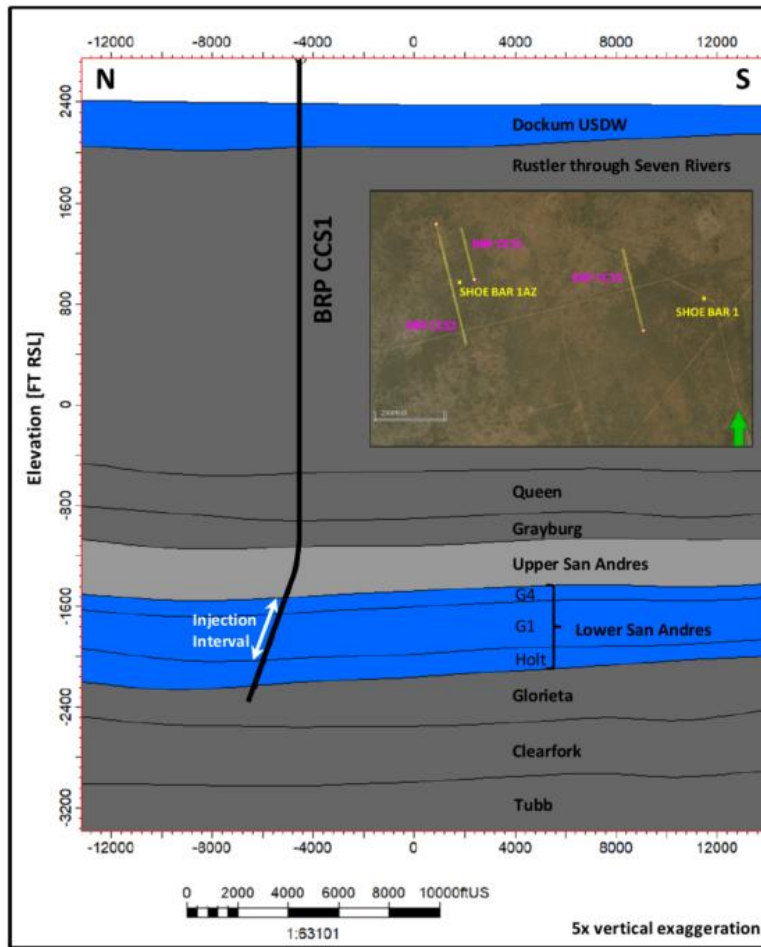

Figure 2—Wellbore trajectory of BRP CCS1 with completion interval in sub-zone G4-G1 highlighted in white.

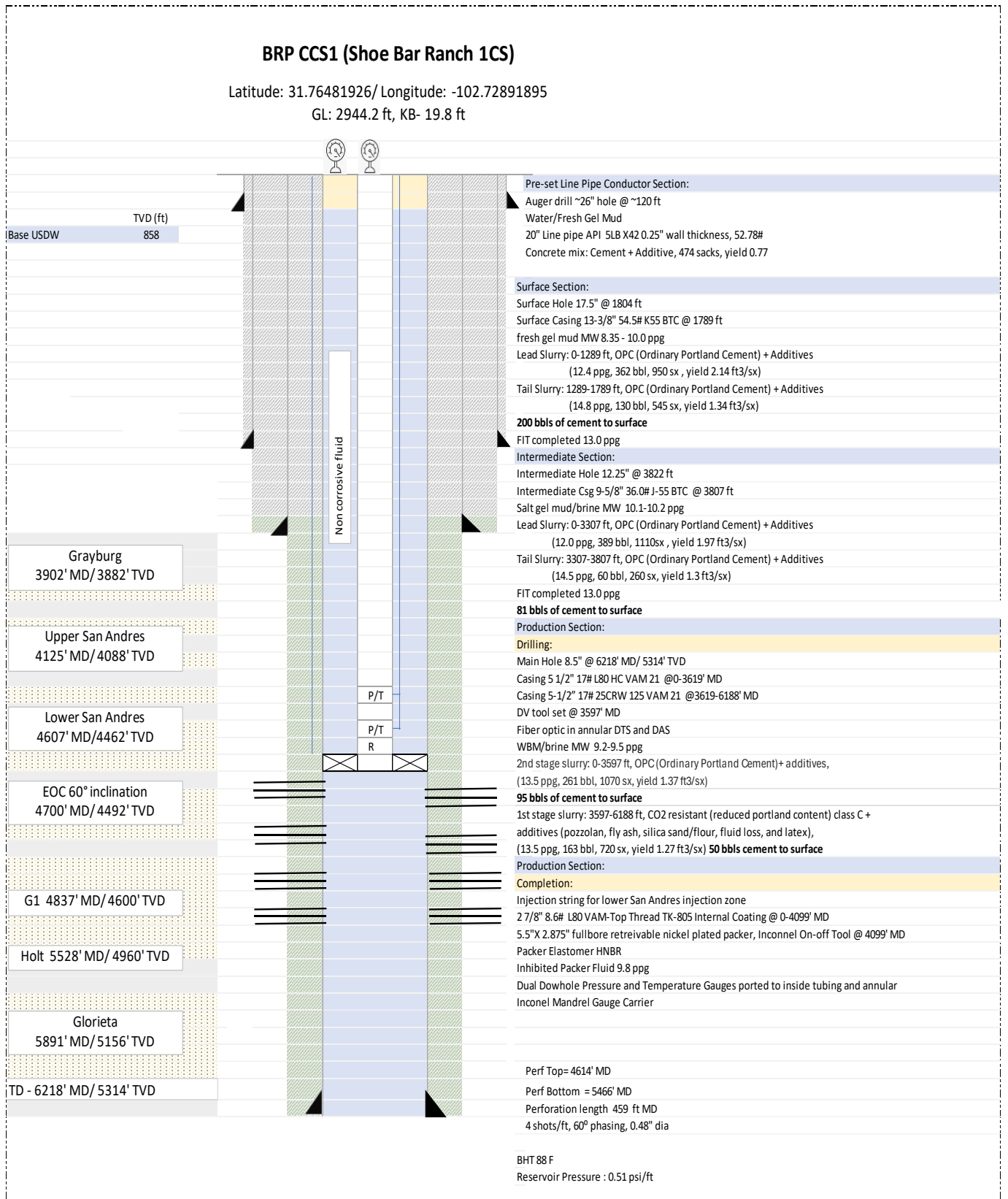

Figure 3—BRP CCS1 well schematic (as drilled)

Details of BRP CCS1 well design are provided in the following tables. Table 3 contains the open hole diameters of each section, Table 4 lists the casing specifications, and Table 5 details the casing material properties. In addition, Table 7 contains the upper completion equipment specifications, and Table 8 shows the tubing material properties.

Table 3—Open Hole Diameters and Intervals for BRP CCS1

Name	Depth Interval (ft)	Open Hole Diameter (in.)	Comment
Conductor Section	0 to 120	26	Auger drill
Surface section	0 to 1,804	17 ½	Below base of USDW
Intermediate section	1,804 to 3,807	12 ¼	Intermediate section
Long string section	3,807 to 6,218	8 ½	To total depth (TD)

Notes:

- The well TD included approximately 50 ft of cement shoe track, and 100 ft casing rat hole for completion operations in the Glorieta Formation.
- The USDW depth was confirmed with open hole logs.

Table 4—Casing Specifications for BRP CCS1

Name	Depth Interval (ft)	OD (in.)	ID (in.)	Drift (in.)	Weight (lbm/ft)	Grade (API)	Coupling
Pre-set conductor	0 to 120	20	19.5	19.25	52.78	5LB X42	weld
Surface string	0 to 1,798	13 3/8	12.615	12.459	54.5	K-55	BTC
Intermediate string	0 to 3,822	9 5/8	8.921	8.765	36	J-55	BTC
Long string	0 to 3,619	5 1/2	4.892	4.767	17	L80	Vam 21
Long string	3,619 to 6,188	5 1/2	4.892	4.767	17	SM25CRW-125	Vam 21

Note: OD is outer diameter; ID is inner diameter

Table 5—Casing Material Properties for BRP CCS1

Casing	Depth Interval (ft)	Burst (psi)	Collapse (psi)	Body Yield (Klb)
20 in conductor	0 to 120	-	-	-
13 3/8-inch 54.5# K-55 BTC	0 to 1,804	2,730	1,130	853
9 5/8-inch 36# J-55 BTC	0 to 3,822	3,520	2,020	564
5 1/2-inch 17# L80	0 to 3,619	7,740	6,290	397
5 1/2-inch 17# SM25CRW-125	3,619 to 6,188	12,090	7,890	829

Notes:

- A stage tool was located at 3,597 ft in the 5 1/2-inch casing to perform the two-stage cement job.
- The centralization program aimed at 70-90% standoff and was adjusted using the field data for deviation, caliper, and hole conditions.
- DTS/DAS fiber optic cable was deployed alongside the casing as part of the monitoring program. Special clamps, bands, and centralizers were installed to protect the fiber and provide a marker for wireline operations.

Table 6—Direction Design for BRP CCS1

Name	MD (ft)	Inclination (°)	Azimuth (°)	TVD (ft)	Dogleg (°/100ft)	Description
SHL	0	0	0	0	0.00	Surface hole location
KOP	2627	0	346	2627	0.00	Kick of point
EOC	4700	60	346	4492	5.00	End of curve
Well TD	6218	60	346	5314	0.00	Tangent section

Table 7—Upper Completion Equipment Specifications for BRP CCS1

Name	Depth Interval (ft)	OD (in.)	ID (in.)	Drift (in.)	Weight (lbm/ft)	Grade (API)	Coupling
Injection (Coated TK-805) tubing	0 to 4,099	2 7/8	2.441	2.347	8.6	L80	Special
Nickel Plated Packer with HBNR (RGD) Elastomers)	4,099 to 4,107	4-5/8	2.38	2.347	-	P-110 (Nickel plated)	VAM-TOP

Table 8—Tubing Material Properties for BRP CCS1

Tubing	Depth Interval (ft)	Burst (psi)	Collapse (psi)	Body Yield (Ksi)
2 7/8-in. 6.5# L80 Special – Coated TK-805	0 to 4,099	10,570	11,170	80

Notes:

- Pressure and temperature gauges are external tubing-deployed and ported to the tubing and casing. Cable material is Inconel®, and gauge carriers are made by CO₂-resistant material.
- The internal diameter of the tubing is slightly reduced due to the TK-805 coating that was applied.
- The annular space between the 2 7/8-inch tubing and 5 1/2-inch casing is filled with packer fluid.

4.1.2 Drilling Procedure for BRP CCS1

The next section describes the drilling procedure for BRP CCS1.

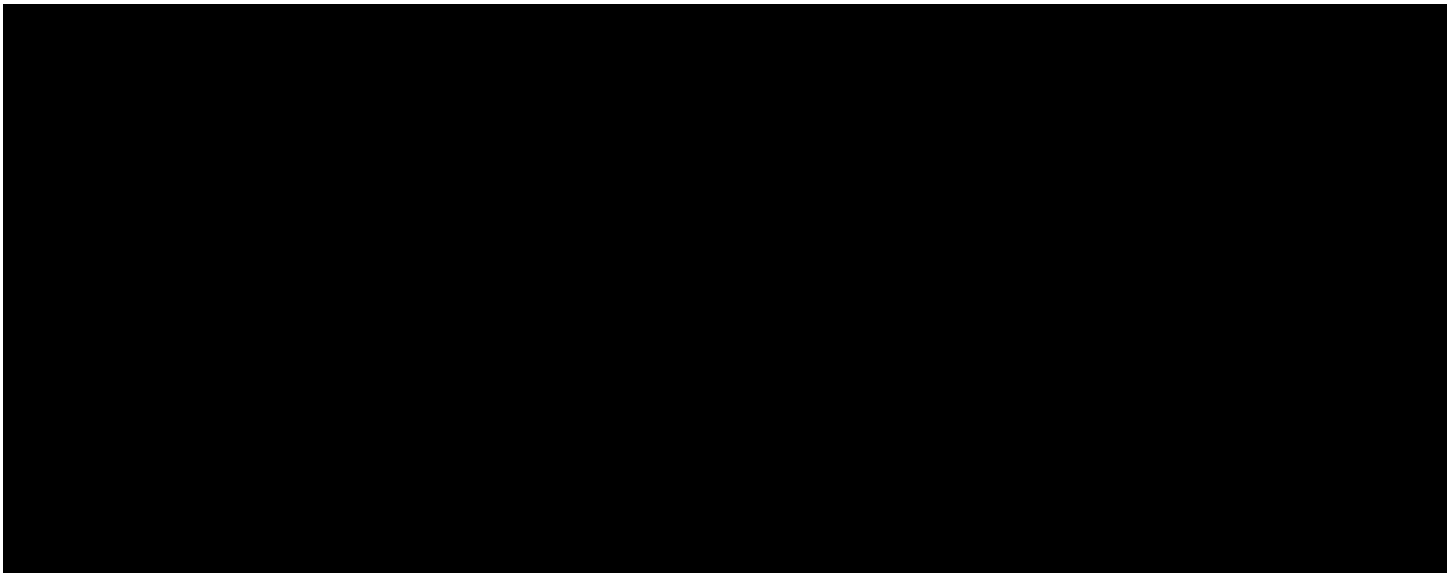

Plan revision number: 5
Plan revision date: 10/16/2025

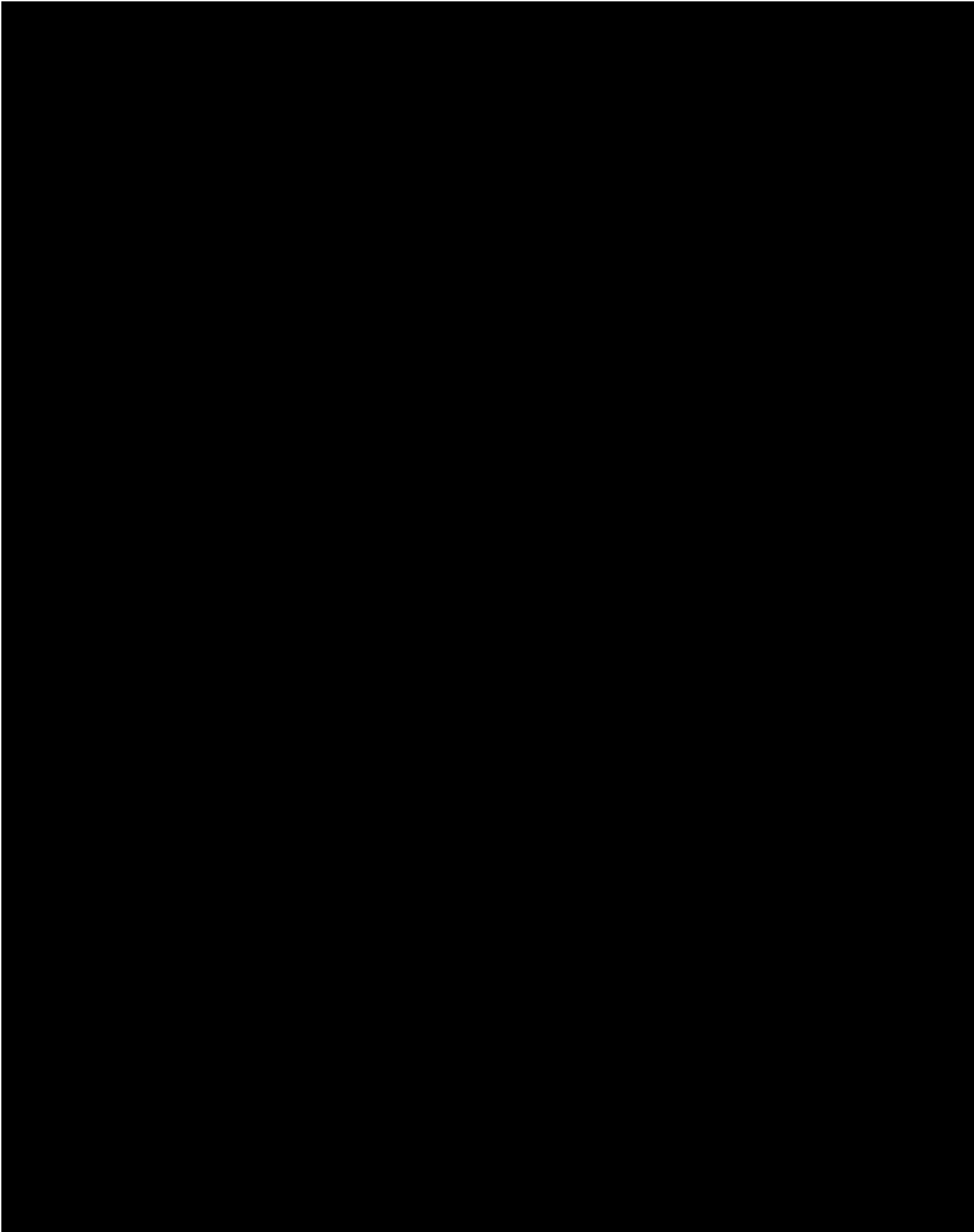

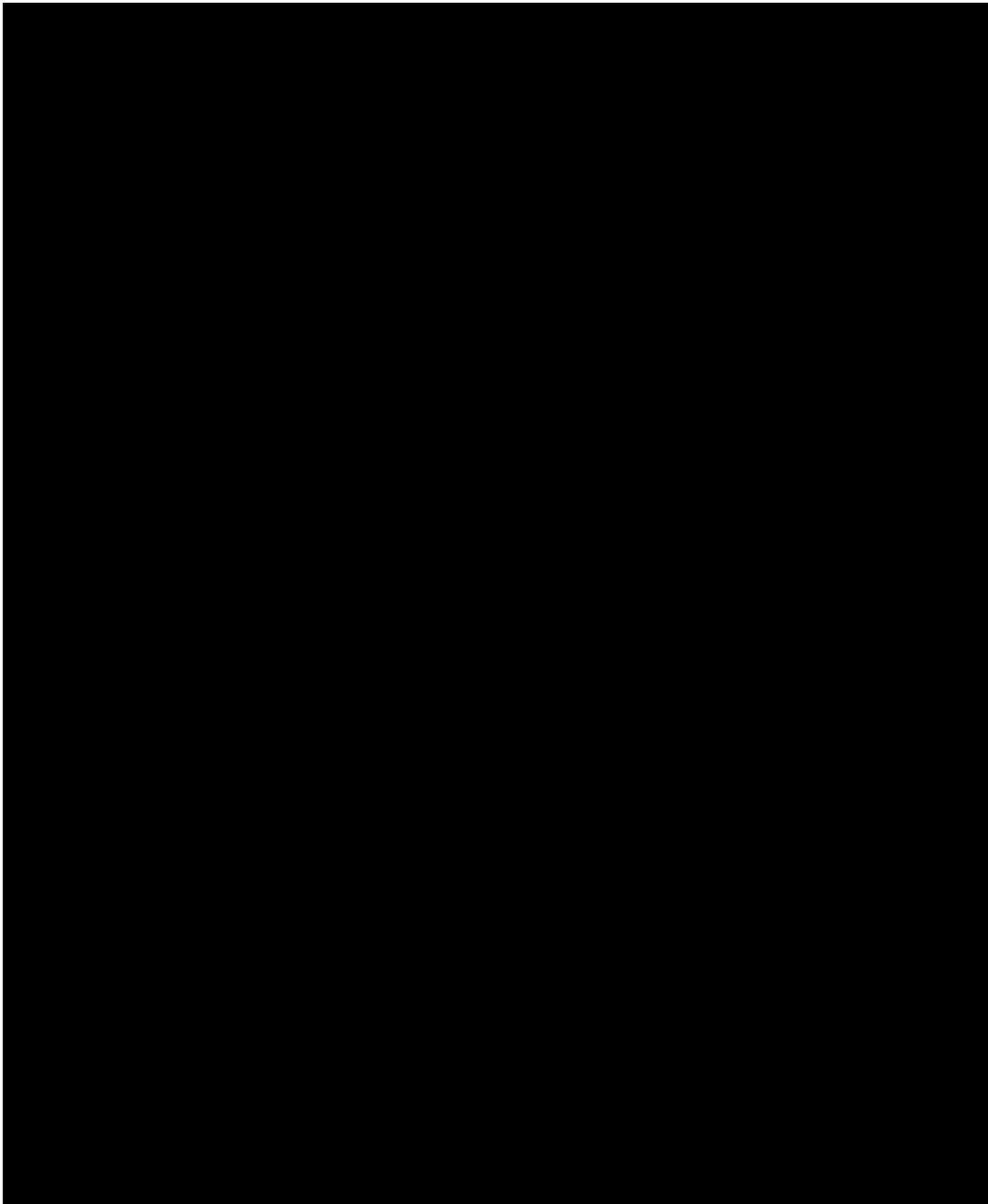

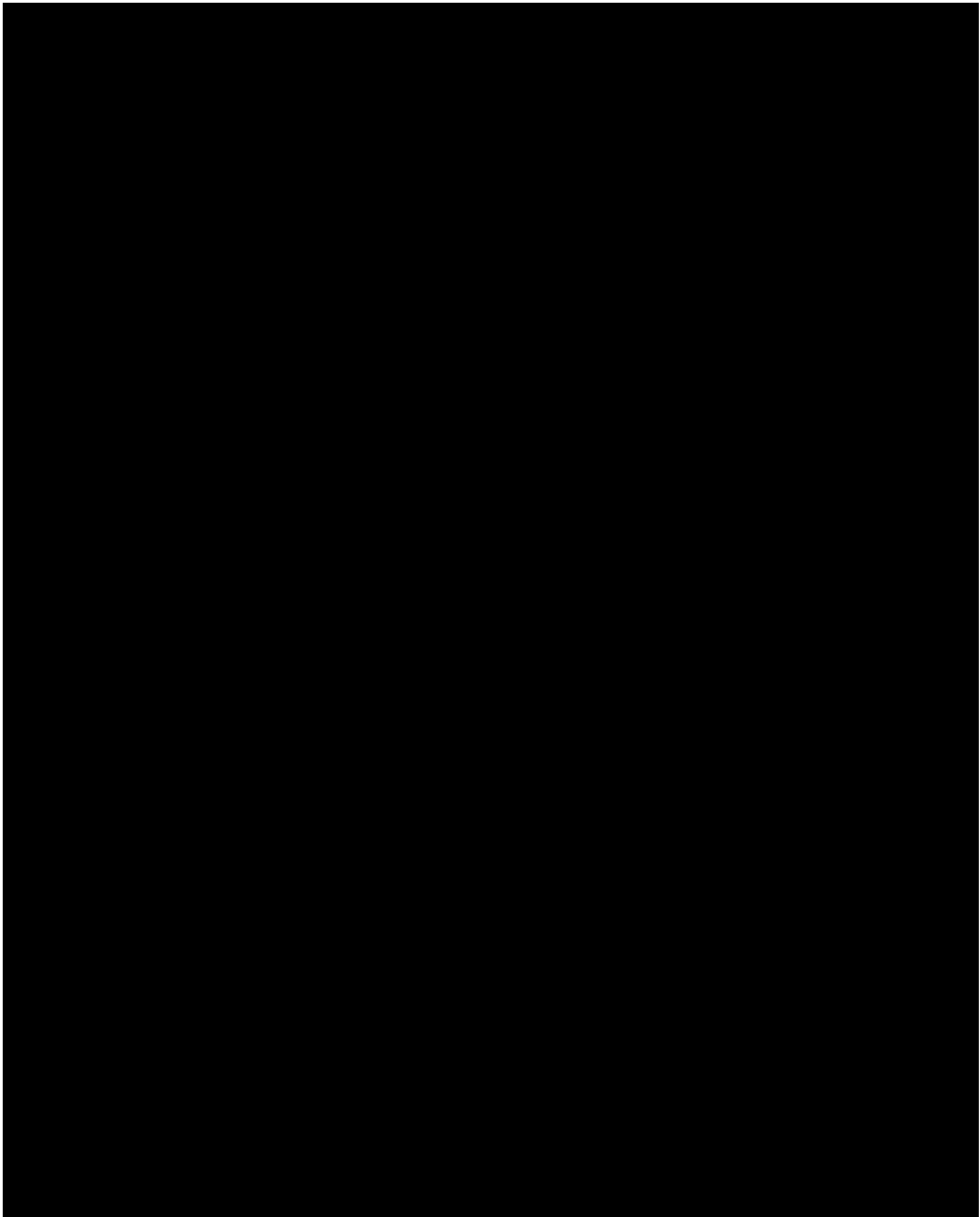

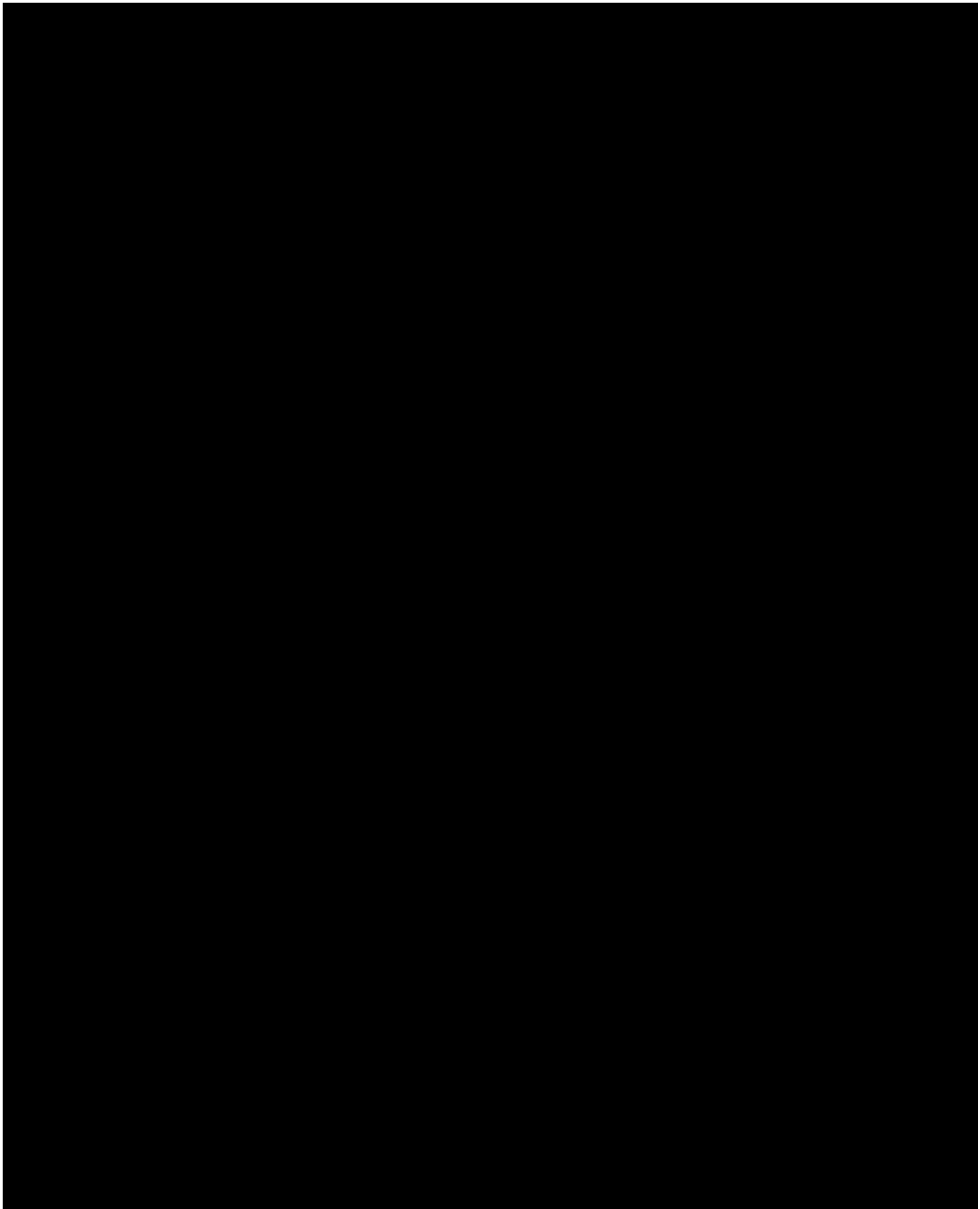

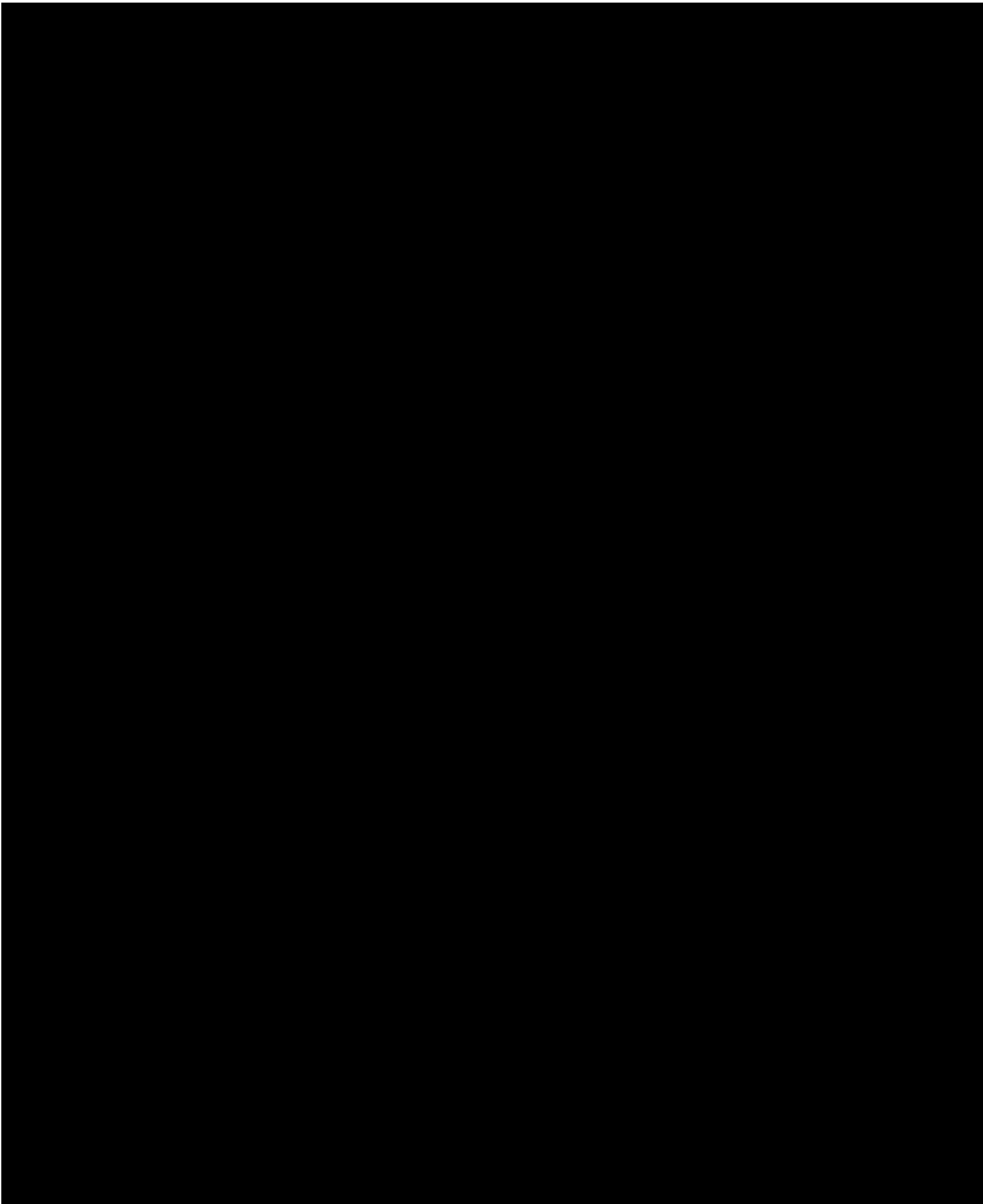

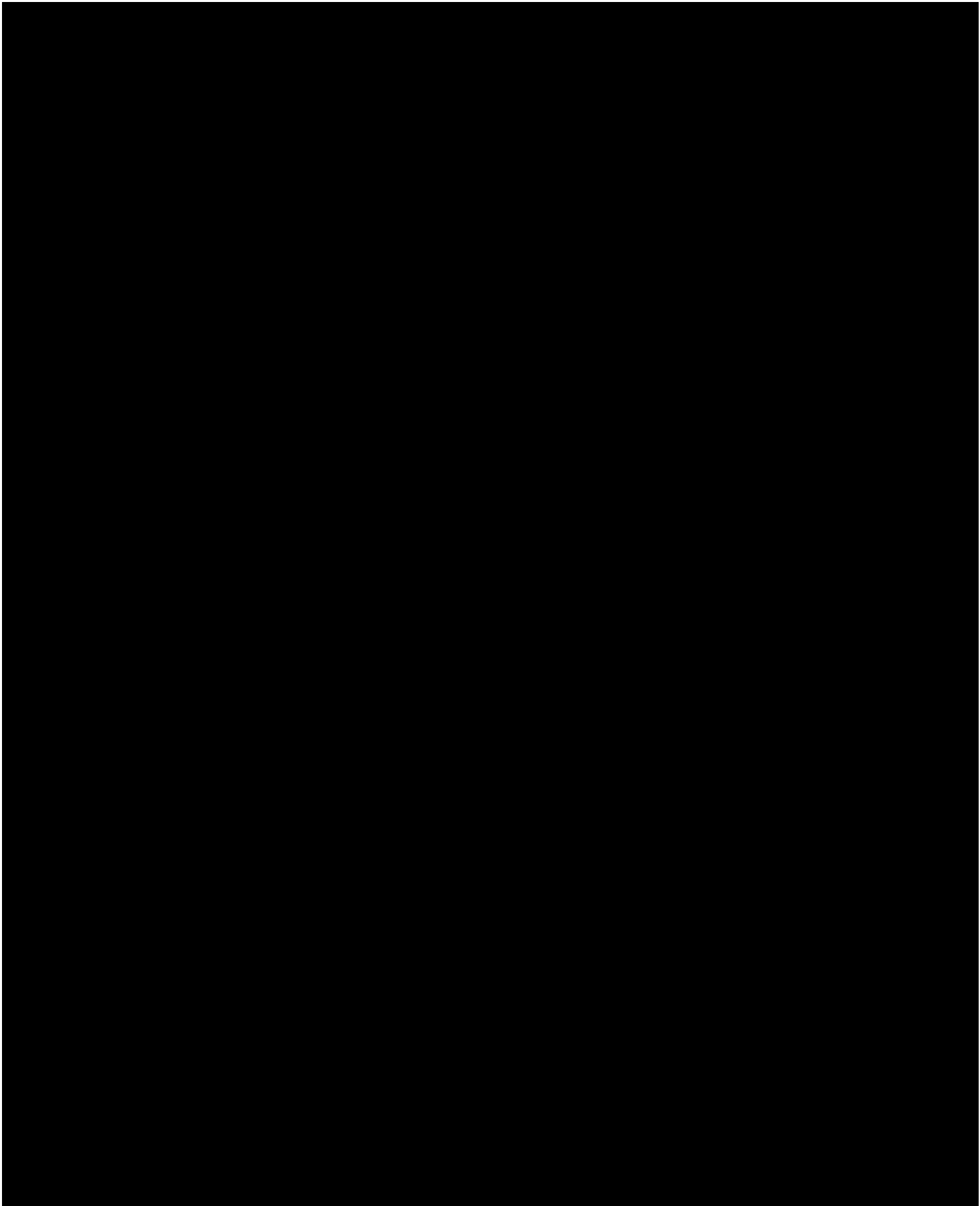

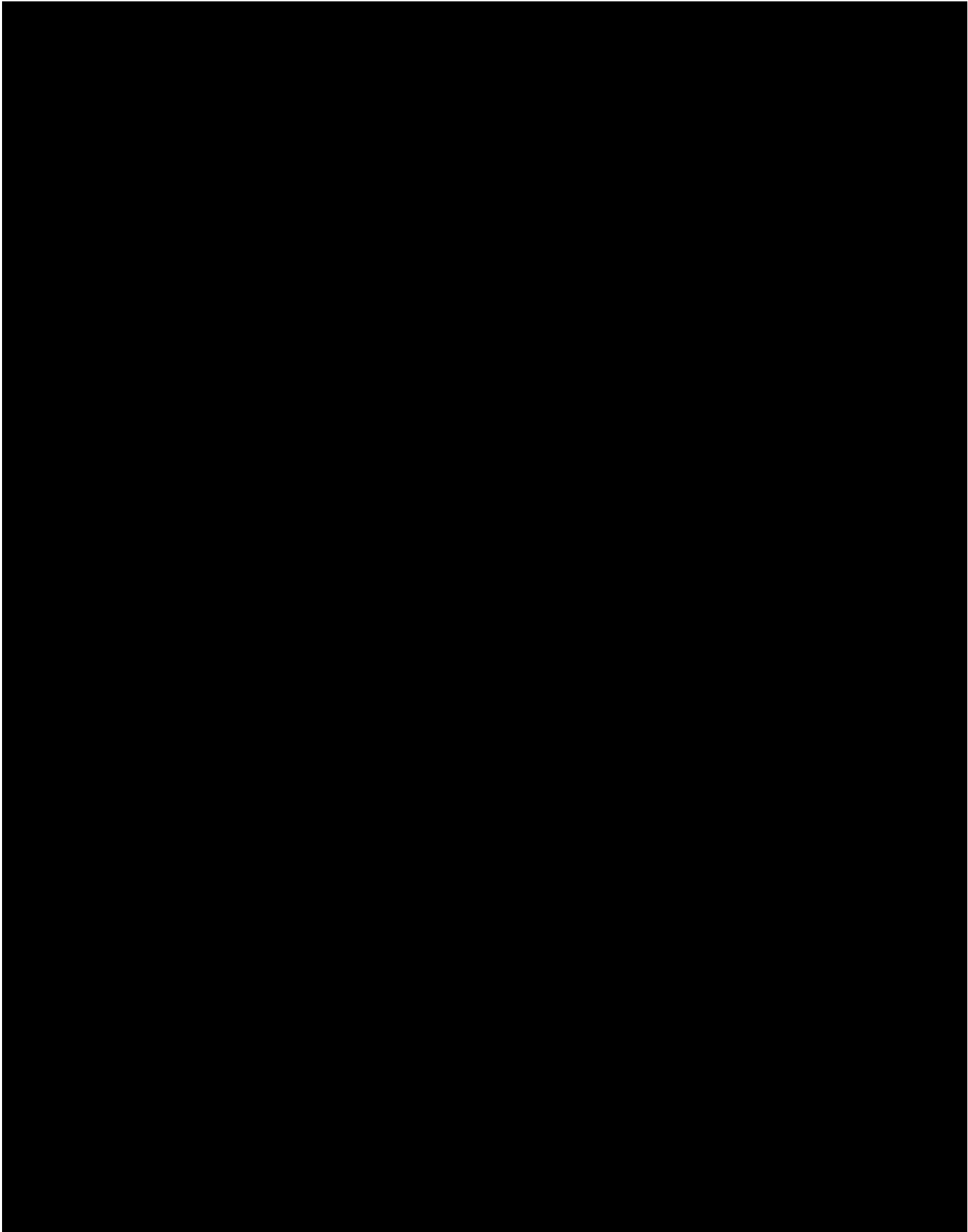

4.2 BRP CCS2

The BRP CCS2 well design includes three main casing sections: 1) surface casing to cover the USDW and provide integrity while drilling to the Injection Zone, 2) intermediate section, and 3) a long string section to acquire formation data and isolate the target formation while running the upper completion equipment. Figure 4 presents wellbore trajectory of BRP CCS2 and Figure 5 is the BRP CCS2 as-drilled wellbore schematic

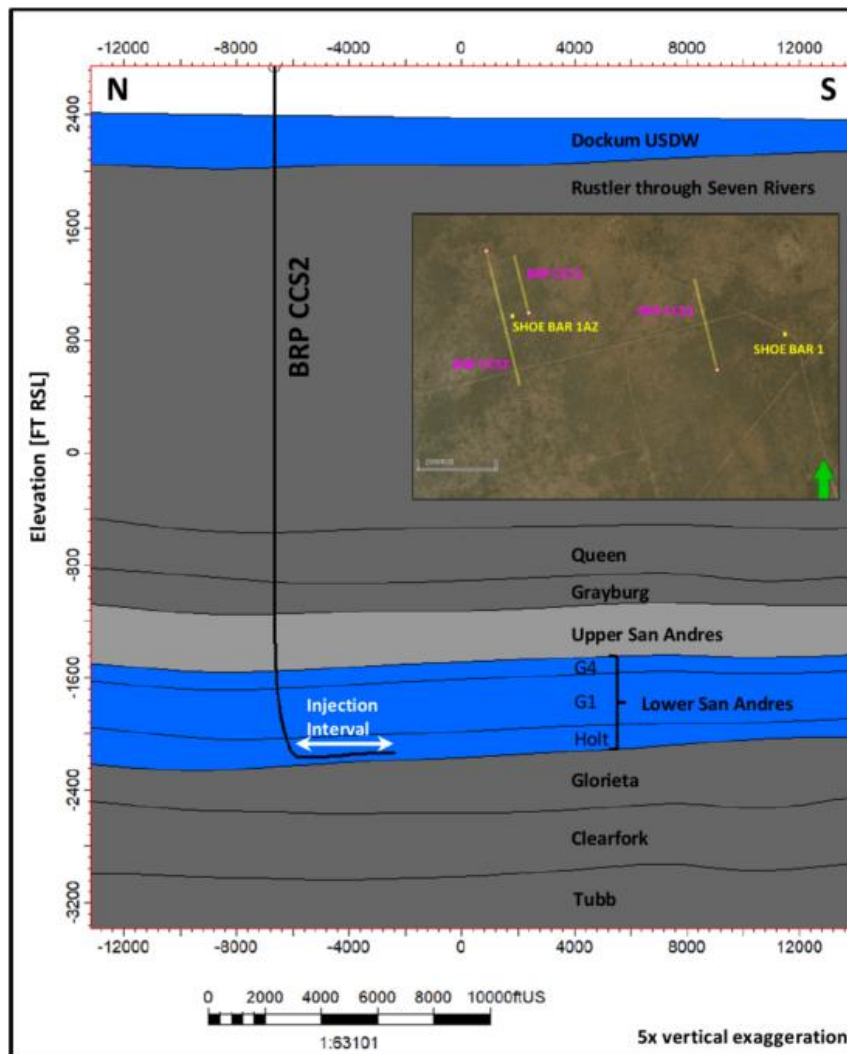

Figure 4—Wellbore trajectory of BRP CCS2 horizontal well with completion interval in sub-zone Holt highlighted in white.

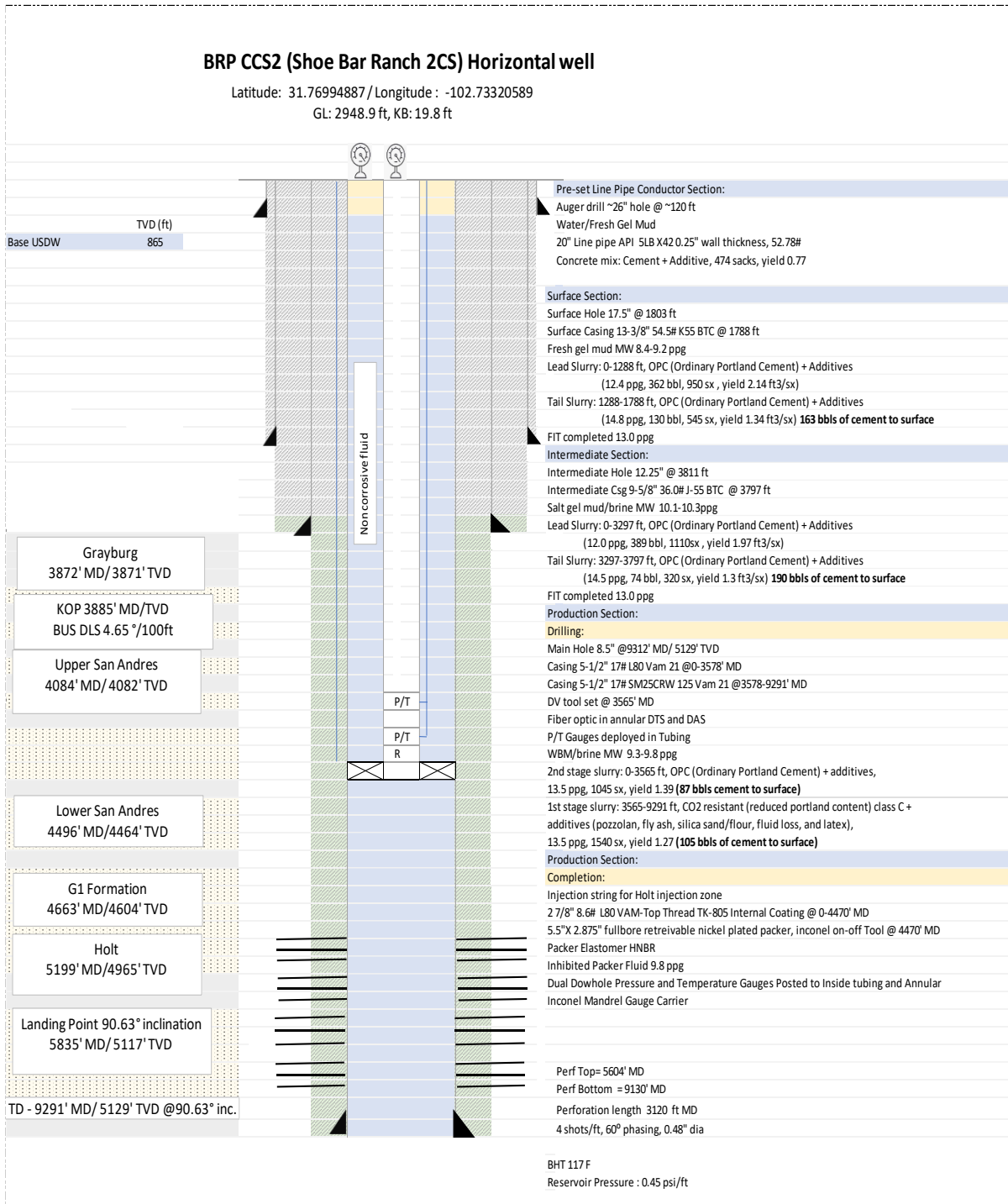

Figure 5—BRP CCS2 well schematic (as drilled)

4.2.1 Design for BRP CCS2

Details regarding the BRP CCS2 well design are provided in the following tables. Table 9 contains the open hole diameters of each section, Table 10 lists the casing specifications, and Tables 11 details the casing material properties. In addition, Table 13 contains the upper completion equipment specifications, and Table 14 shows the tubing material properties.

Table 9—Open Hole Diameters and Intervals for BRP CCS2

Name	Depth Interval (ft)	Open Hole Diameter (in.)	Comment
Conductor Section	0 to 120	26	Auger drill
Surface section	0 to 1,803	17 1/2	Below base of USDW
Intermediate section	1,803 to 3,811	12 1/4	Intermediate section
Long string section	3,811 to 9,312	8 1/2	To total depth (TD)

Notes:

- The well TD included approximately 80 ft of cement shoe track in the Holt Formation.
- The USDW depth was confirmed with open hole logs.

Table 10—Casing Specifications for BRP CCS2

Name	Depth Interval (ft)	OD (in.)	ID (in.)	Drift (in.)	Weight (lbm/ft)	Grade (API)	Coupling
Pre-set conductor	0 to 120	20	19.5	19.25	52.78	5LB X42	weld
Surface string	0 to 1,788	13 3/8	12.615	12.459	54.5	K-55	BTC
Intermediate string	0 to 3,797	9 5/8	8.921	8.765	36	J-55	BTC
Long string	0 to 3,578	5 1/2	4.892	4.767	17	L80	Vam 21
Long string	3,578 to 9,291	5 1/2	4.892	4.767	17	SM25CRW-125	Vam 21

Table 11—Casing Material Properties for BRP CCS2

Casing	Depth Interval (ft)	Burst (psi)	Collapse (psi)	Body Yield (Klb)
20-inch conductor	0 to 120	-	-	-
13 3/8-inch 54.5# K-55 BTC	0 to 1,788	2,730	1,130	853
9 5/8-inch 36# J-55 BTC	0 to 3,797	3,520	2,020	564
5 1/2-inch 17# L80	0 to 3,578	7,740	6,290	397
5 1/2-inch 17# SM25CRW-125	3,578 to 9,291	12,090	7,890	829

Notes:

- A stage tool is located at 3,565 ft MD in the 5 1/2-inch casing to perform the two-stage cement job.
- The centralization program aimed for 70-90% standoff and was adjusted using the field data for deviation, caliper, and hole conditions.
- DTS/DAS fiber optic cable were deployed alongside the casing as part of the monitoring program. Special clamps, bands, and centralizers were installed to protect the fiber and provide a marker for wireline operations.

Table 12—Direction design for BRP CCS2

Name	MD (ft)	Inclination (°)	Azimuth (°)	TVD (ft)	Dogleg (°/100ft)	Description
SHL	0	0	0	0	0.00	Surface hole location
KOP	3,885	0	346	3885	4.65	Kick of point
LP	5,835	90.63	166	5117	4.64	Landing point
Well TD	9,291	90.53	166	5083	0.00	Lateral section

Table 13—Upper Completion Equipment Specifications for BRP CCS2

Name	Depth Interval (ft)	OD (in.)	ID (in.)	Drift (in.)	Weight (lbm/ft)	Grade (API)	Coupling
Injection (Coated TK-805) tubing	0 to 4,470	2 7/8	2.441	2.347	6.5	L80	Special
Nickel Plated Packer with HBNR (RGD) Elastomers)	4,470-4,478	4 5/8	2.38	2.347	-	P-110 (Nickel plated)	VAM-TOP

Table 14—Tubing Material Properties for BRP CCS2

Tubing	Depth Interval (ft)	Burst (psi)	Collapse (psi)	Body Yield (Ksi)
2 7/8-in. 6.5# L80 Special – Coated TK-805	0 to 4,470	10,570	11,170	80

Notes:

- Pressure and temperature gauges are tubing-deployed above and below casing. Cable material is Inconel®, and gauge carriers are constructed with CO₂-resistant material.
- The internal diameter of the tubing is slightly reduced due to the TK-805 coating.
- The annular space between the 2 7/8-inch tubing and 5 1/2-inch casing is filled with packer fluid.

4.2.2 Drilling Procedure for BRP CCS2

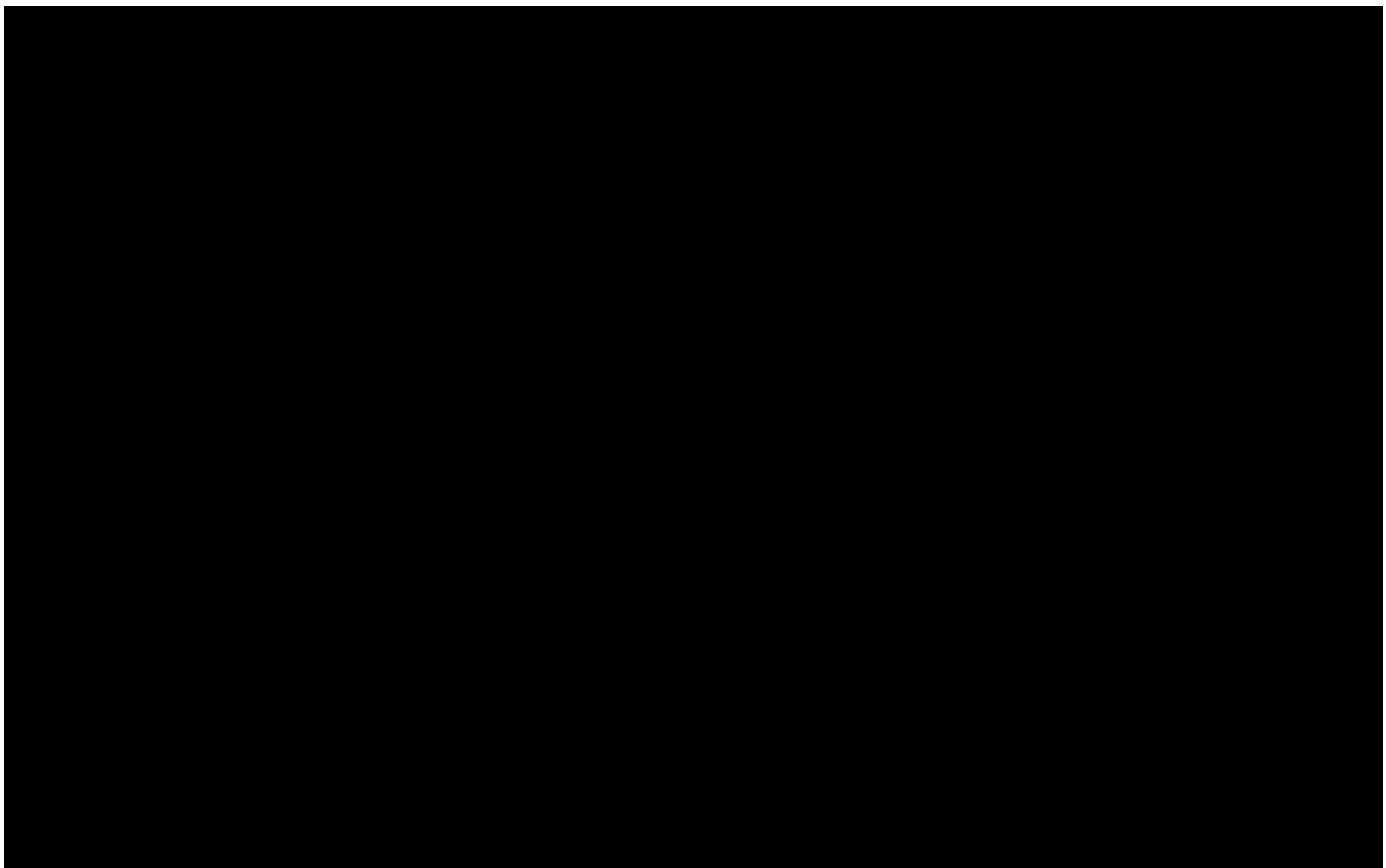

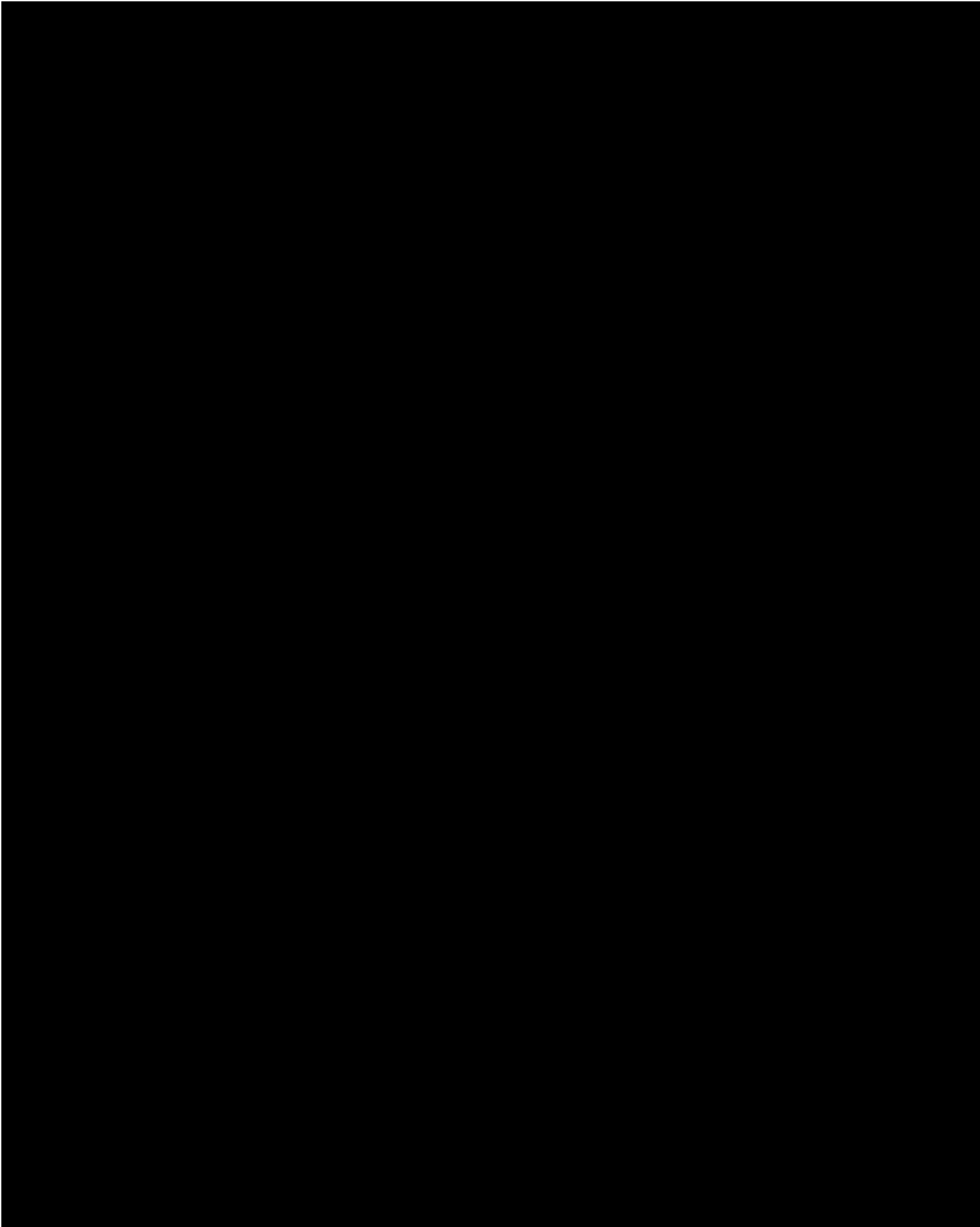

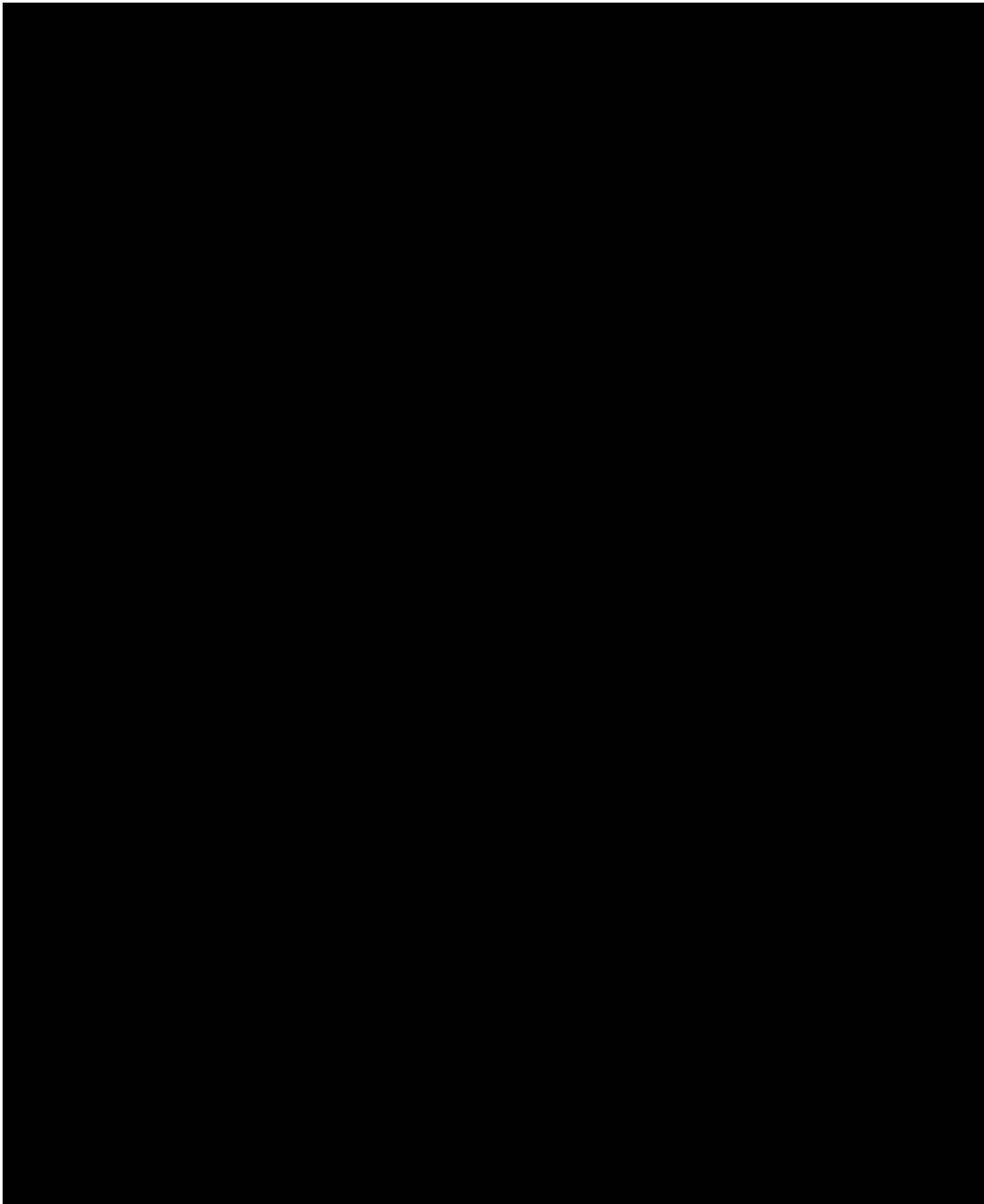

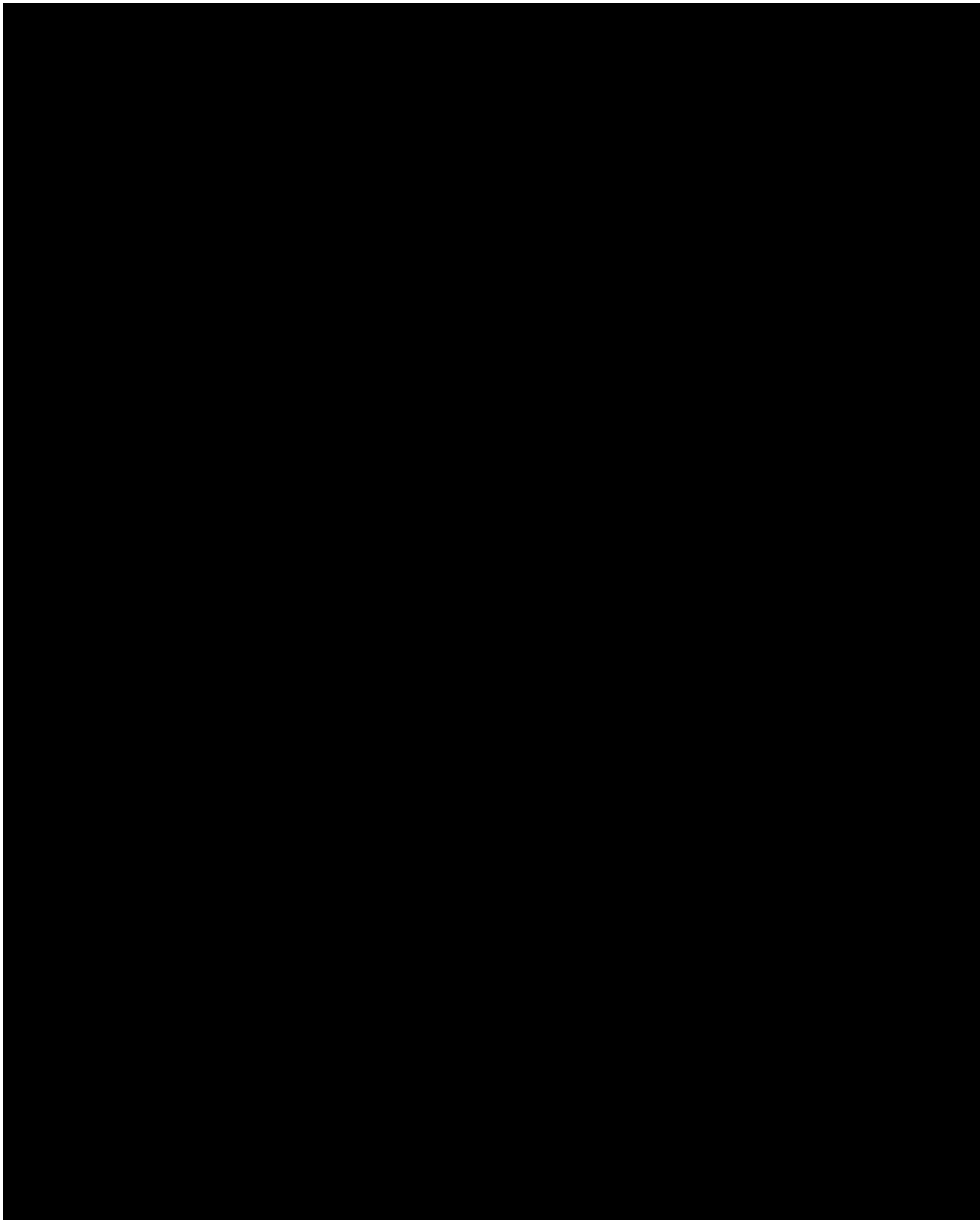

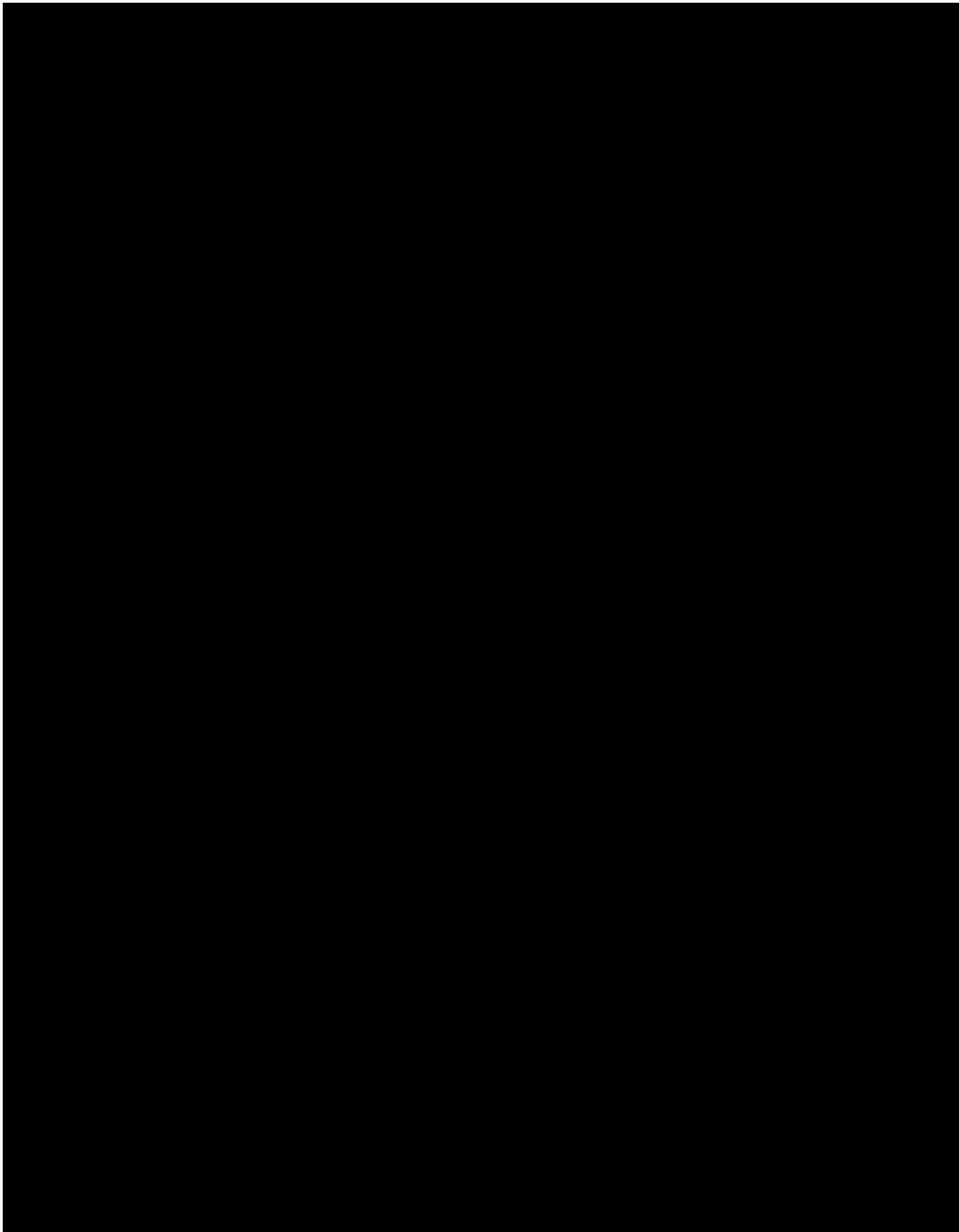

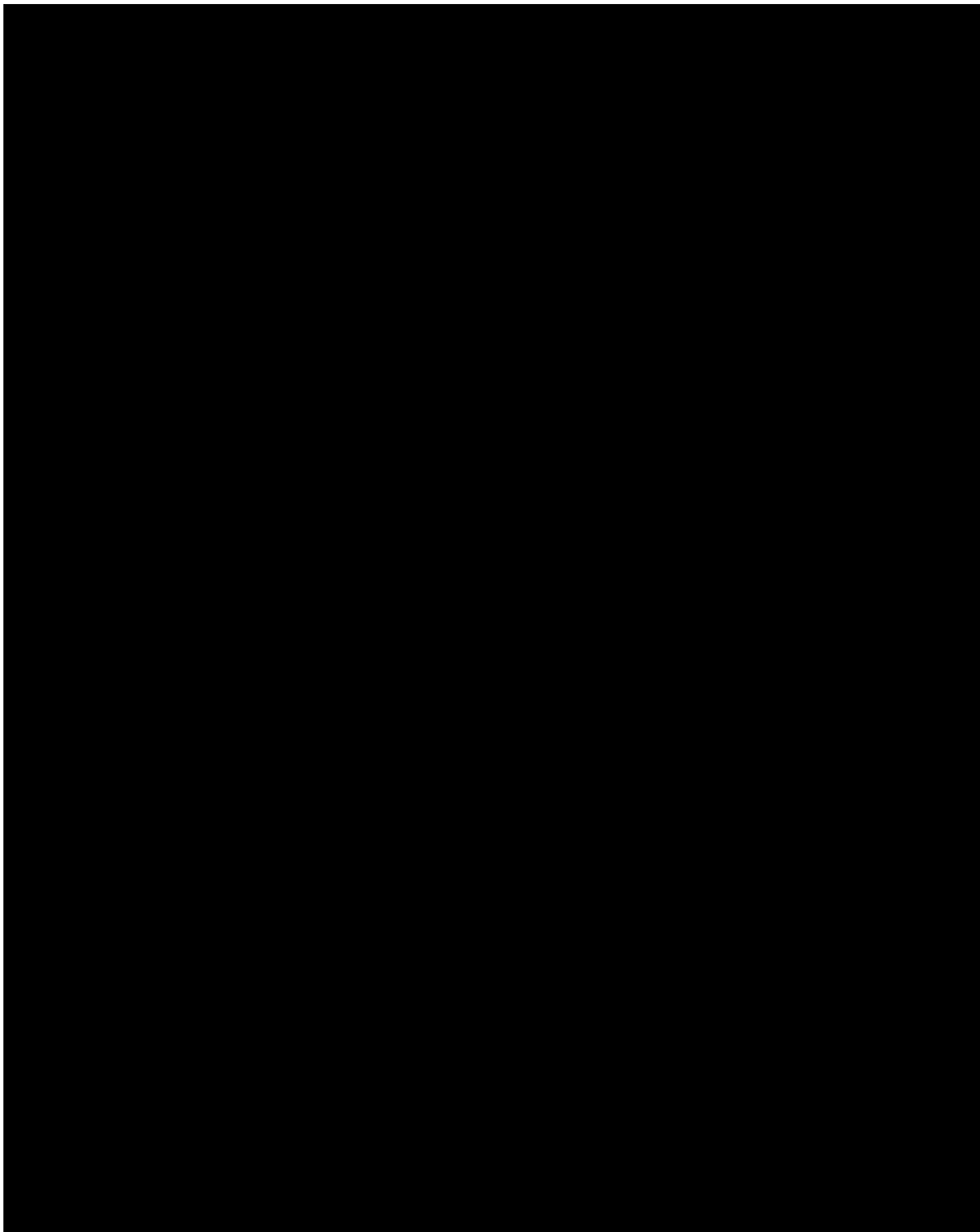

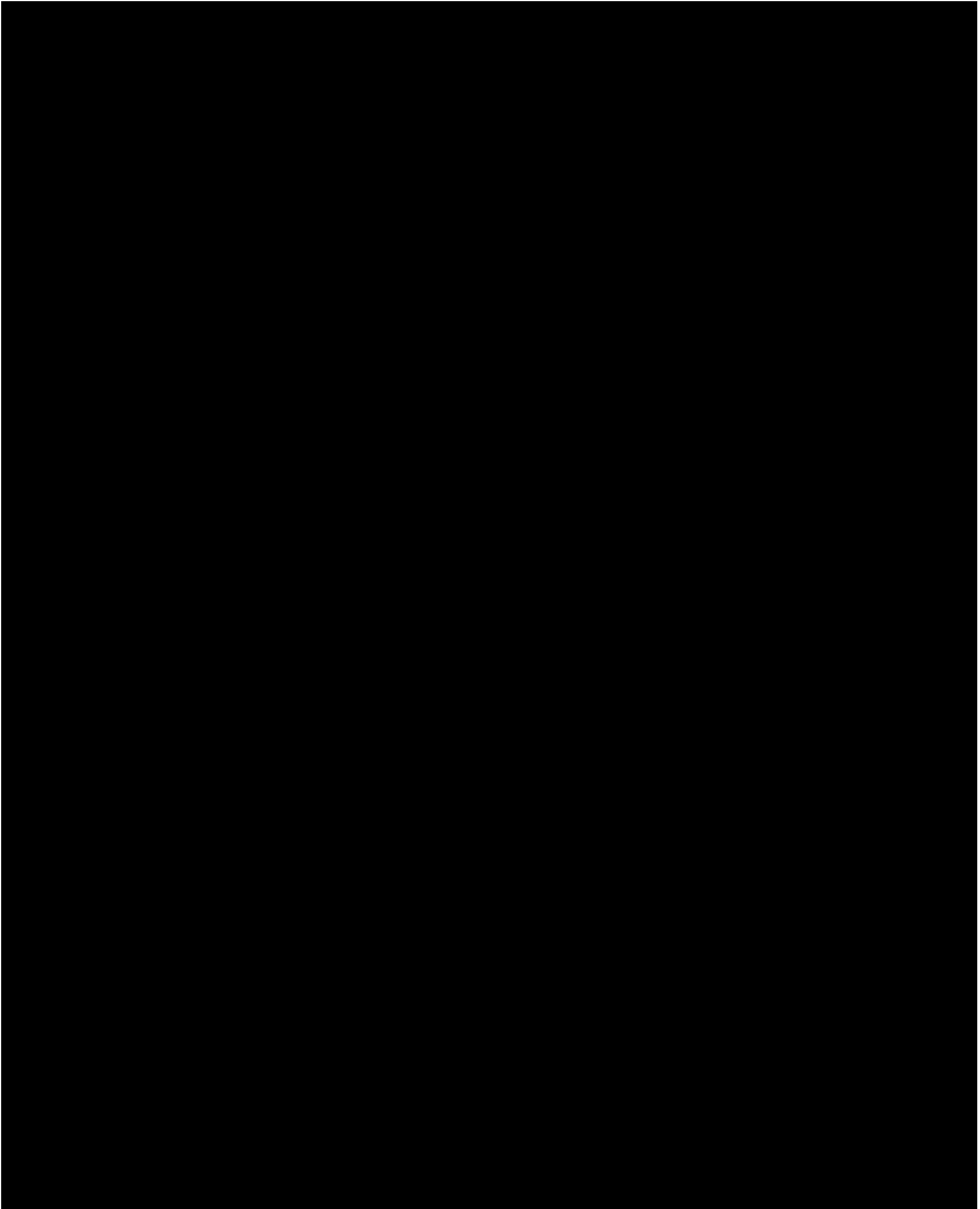

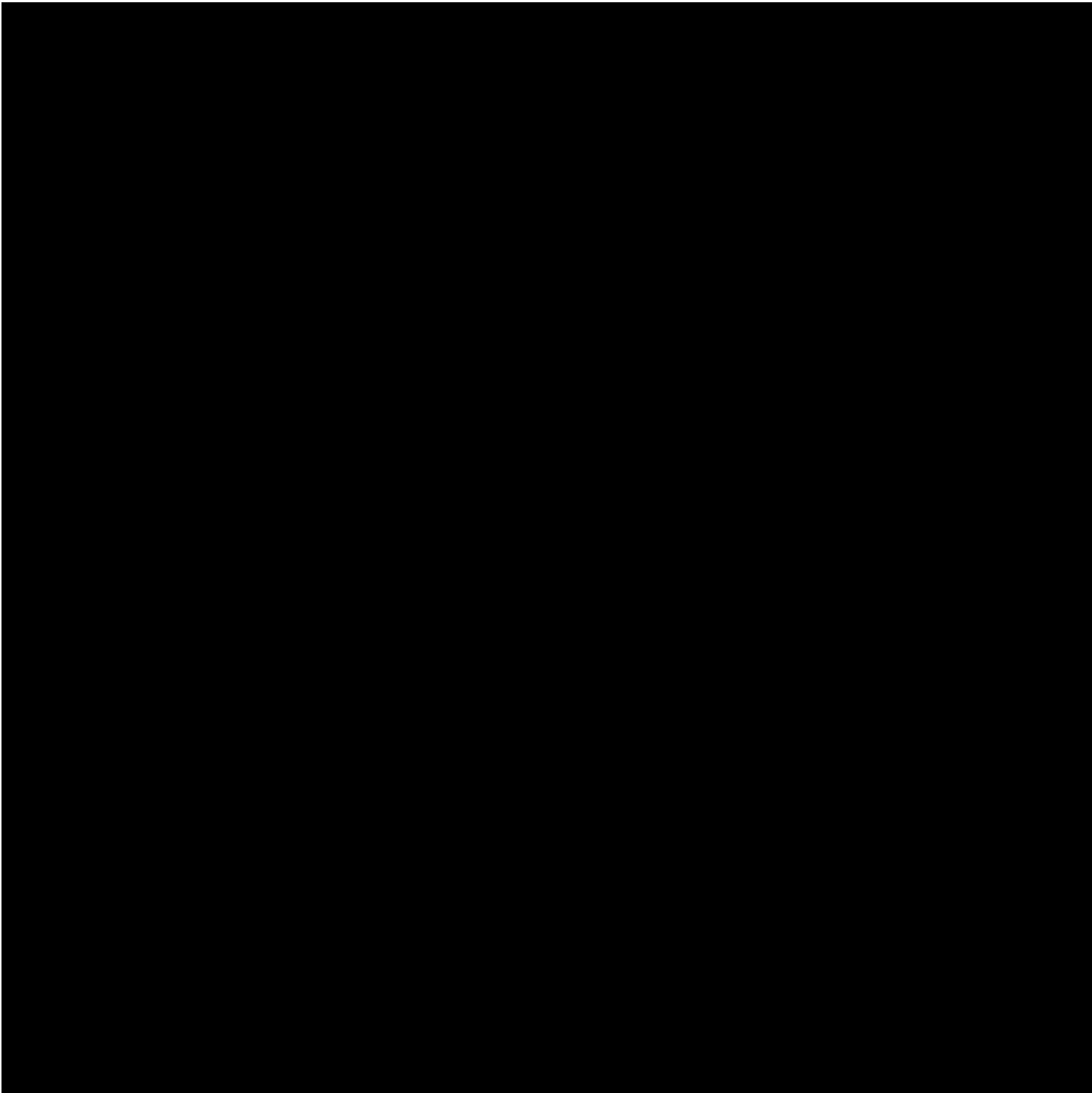

4.3 BRP CCS3

4.3.1 Design for BRP CCS3

The BRP CCS3 well design includes three main casing sections: 1) surface casing to cover the USDW and provide integrity while drilling to the Injection Zone, 2) intermediate section, and 3) a long string section to acquire formation data and isolate the target formation while running the upper completion equipment. Figure 6 presents wellbore trajectory of BRP CCS3 and Figure 7 is the BRP CCS3 as-drilled wellbore schematic.

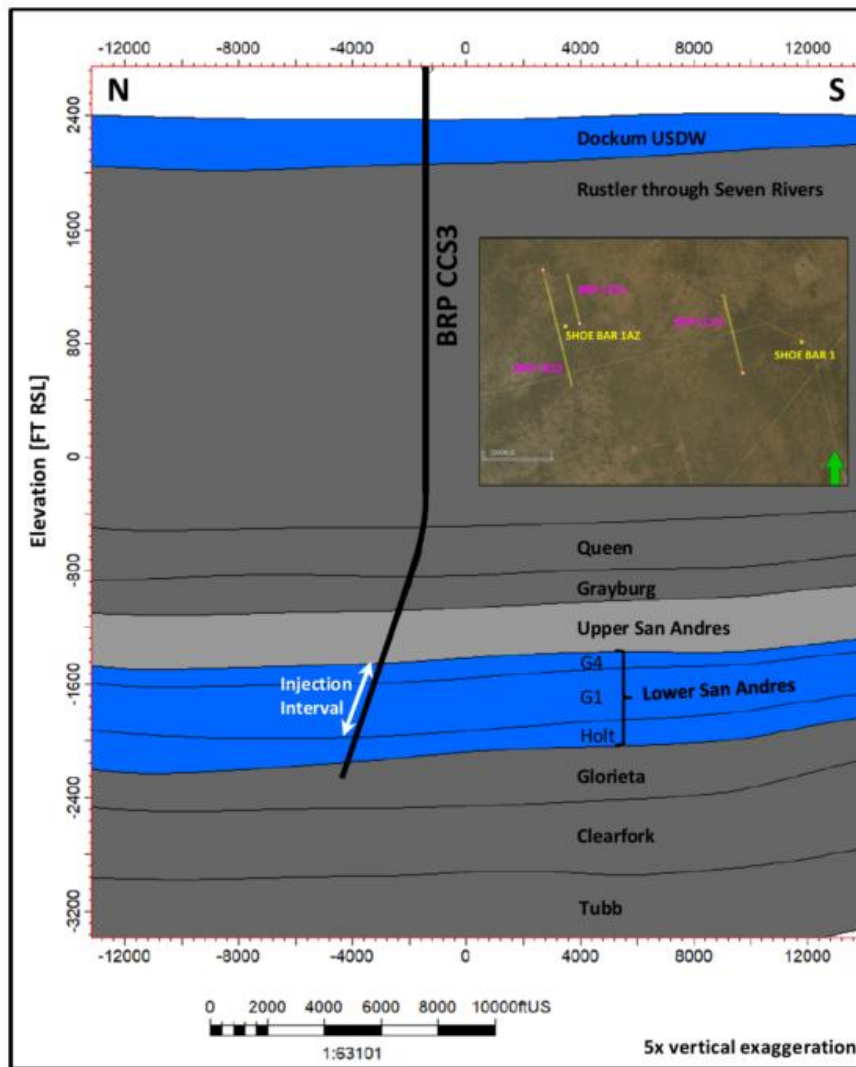

Figure 6—Wellbore trajectory of BRP CCS3 with completion interval in sub-zone G4-G1 highlighted in white

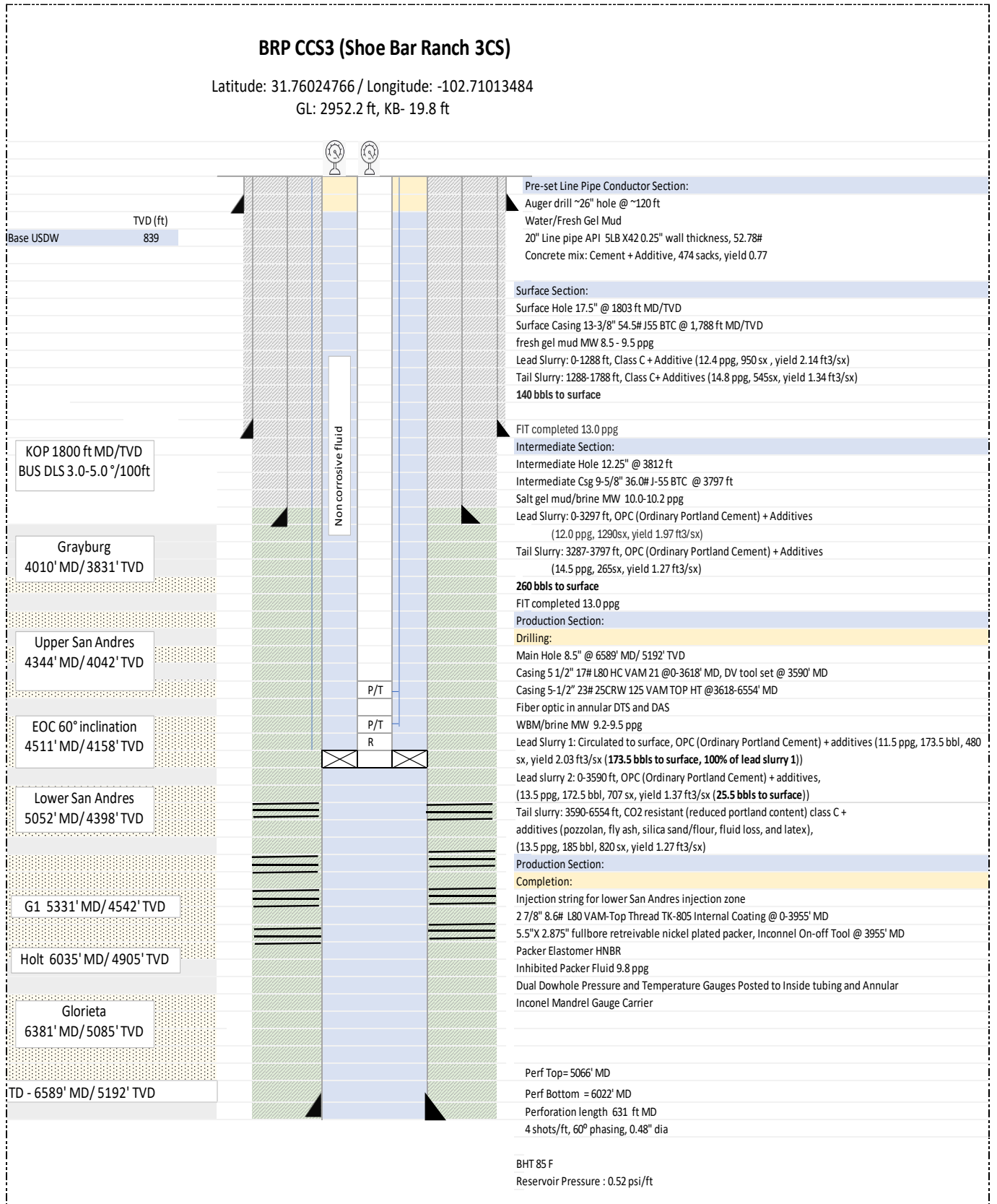

Figure 7—BRP CCS3 well proposed schematic

Details of BRP CCS3 well design are provided in the following tables. Table 15 contains the open hole diameters of each section, Table 16 lists the casing specifications, and Table 17 details the casing material properties. In addition, Table 19 contains the upper completion equipment specifications, and Table 20 shows the tubing material properties.

Table 15—Open Hole Diameters and Intervals BRP CCS3

Name	Depth Interval (ft)	Open Hole Diameter (in.)	Comment
Conductor Section	0 to 120	26	Auger drill
Surface section	0 to 1,803	17 1/2	Below base of USDW
Intermediate section	1,803 to 3,812	12 1/4	Intermediate section
Long string section	3,812 to 6,589	8 1/2	To total depth (TD)

Notes:

- The well TD includes approximately 80 ft of cement shoe track, and 100 ft casing rat hole for completion operations in the Glorieta Formation.
- The USDW depth were confirmed with open hole logs.

Table 16—Casing Specifications BRP CCS3

Name	Depth Interval (ft)	OD (in.)	ID (in.)	Drift (in.)	Weight (lbm/ft)	Grade (API)	Coupling
Pre-set conductor	0 to 120	20	19.5	19.25	52.78	5LB X42	weld
Surface string	0 to 1,788	13 3/8	12.615	12.459	54.5	K-55	BTC
Intermediate string	0 to 3,797	9 5/8	8.921	8.765	36	J-55	BTC
Long string	0 to 3,618	5 1/2	4.892	4.767	17	L80	Vam 21
Long string	3,618 to 6554	5 1/2	4.892	4.767	23	SM25CRW-125	Vam 21

Table 17—Casing Material Properties for BRP CCS3

Casing	Depth Interval (ft)	Burst (psi)	Collapse (psi)	Body Yield (Klb)
20-inch conductor	0 to 120	-	-	-
13 3/8-inch 54.5# K-55 BTC	0 to 1,788	2,730	1,130	853
9 5/8-inch 36# J-55 BTC	0 to 3,797	3,520	2,020	564
5 1/2-inch 17# L80	0 to 3,618	7,740	6,290	397
5 1/2-inch 17# SM25CRW-125	3,618 to 6554	12,090	7,890	829

Notes:

- The centralization program was aimed at 70- 90% standoff and was adjusted using the field data for deviation, caliper, and hole conditions.
- DTS/DAS fiber optic cable was deployed alongside the casing as part of the monitoring program. Special clamps, bands, and centralizers were installed to protect the fiber and provide a marker for wireline operations.

Table 18—Direction design for BRP CCS3

Name	MD (ft)	Inclination (°)	Azimuth (°)	TVD (ft)	Dogleg (°/100ft)	Description
------	---------	-----------------	-------------	----------	------------------	-------------

Plan revision number: 5
 Plan revision date: 10/16/2025

SHL	0	0	0	0	0.00	Surface hole location
KOP	1800	0	346	1800	0.00	Kick of point
EOC	4511	60	346	4158	5.00	End of curve
Well TD	6589	60	346	5192	0.00	Tangent section

Table 19—Upper Completion Equipment Specifications

Name	Depth Interval (ft)	OD (in.)	ID (in.)	Drift (in.)	Weight (lbm/ft)	Grade (API)	Coupling
Injection (Coated TK-805) tubing	0 to 3955	2 7/8	2.441	2.347	6.5	L80	Special
Nickel Plated Packer with HBNR (RGD) Elastomers)	3,995-3,963	4 5/8	2.38	2.347	-	P-110 (Nickel plated)	VAM-TOP

Table 20—Tubing Material Properties

Tubing	Depth Interval (ft)	Burst (psi)	Collapse (psi)	Body Yield (Ksi)
2 7/8-in. 6.5# L80 Special – Coated TK-805	0 to 3955	10,570	11,170	80

Notes:

- Pressure and temperature gauges were tubing-deployed above and below casing. Cable material is Inconel®, and gauge carriers are constructed with CO₂-resistant material.
- The internal diameter of the tubing is slightly reduced due to the TK-805 coating that was applied.
- The annular space between the 2 7/8-inch tubing and 5 1/2-inch casing is filled with packer fluid.

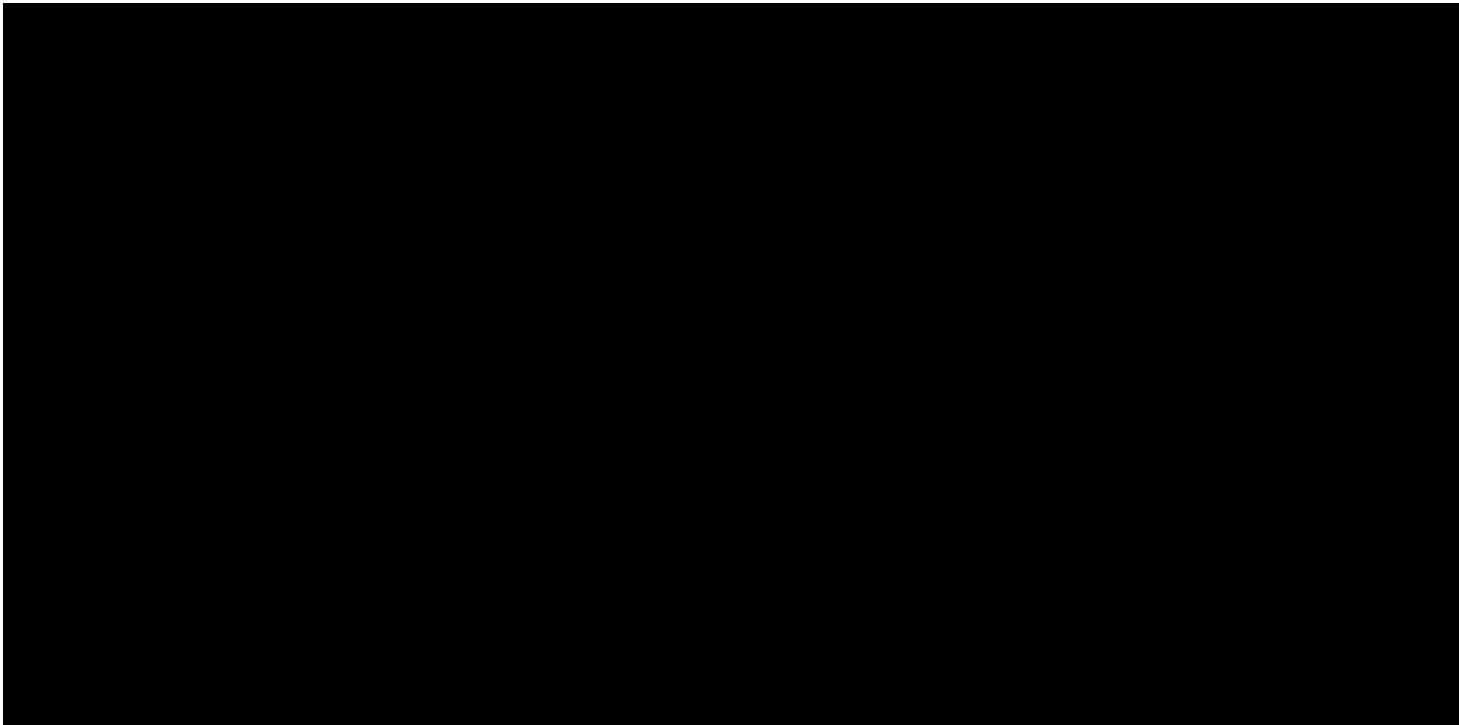

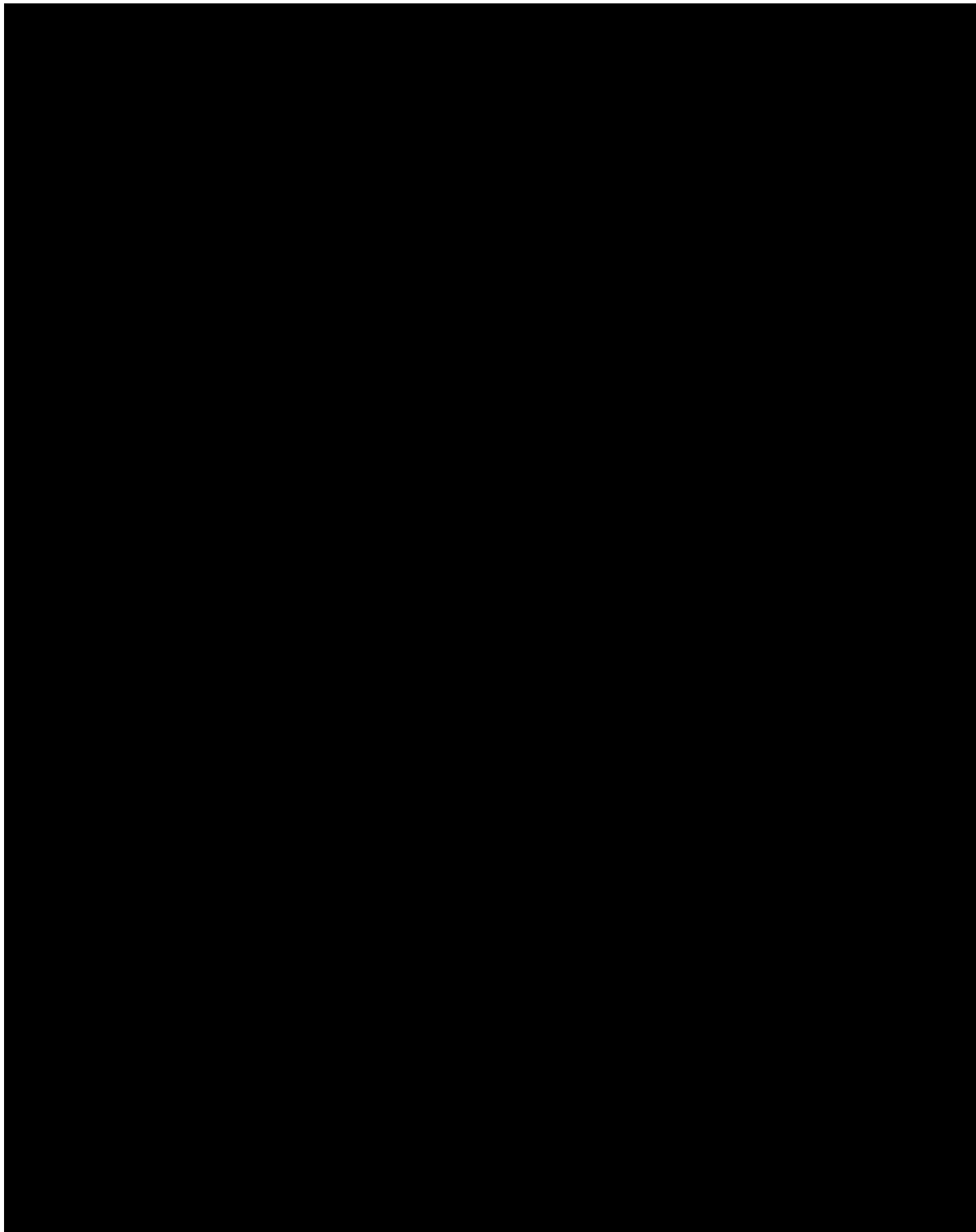

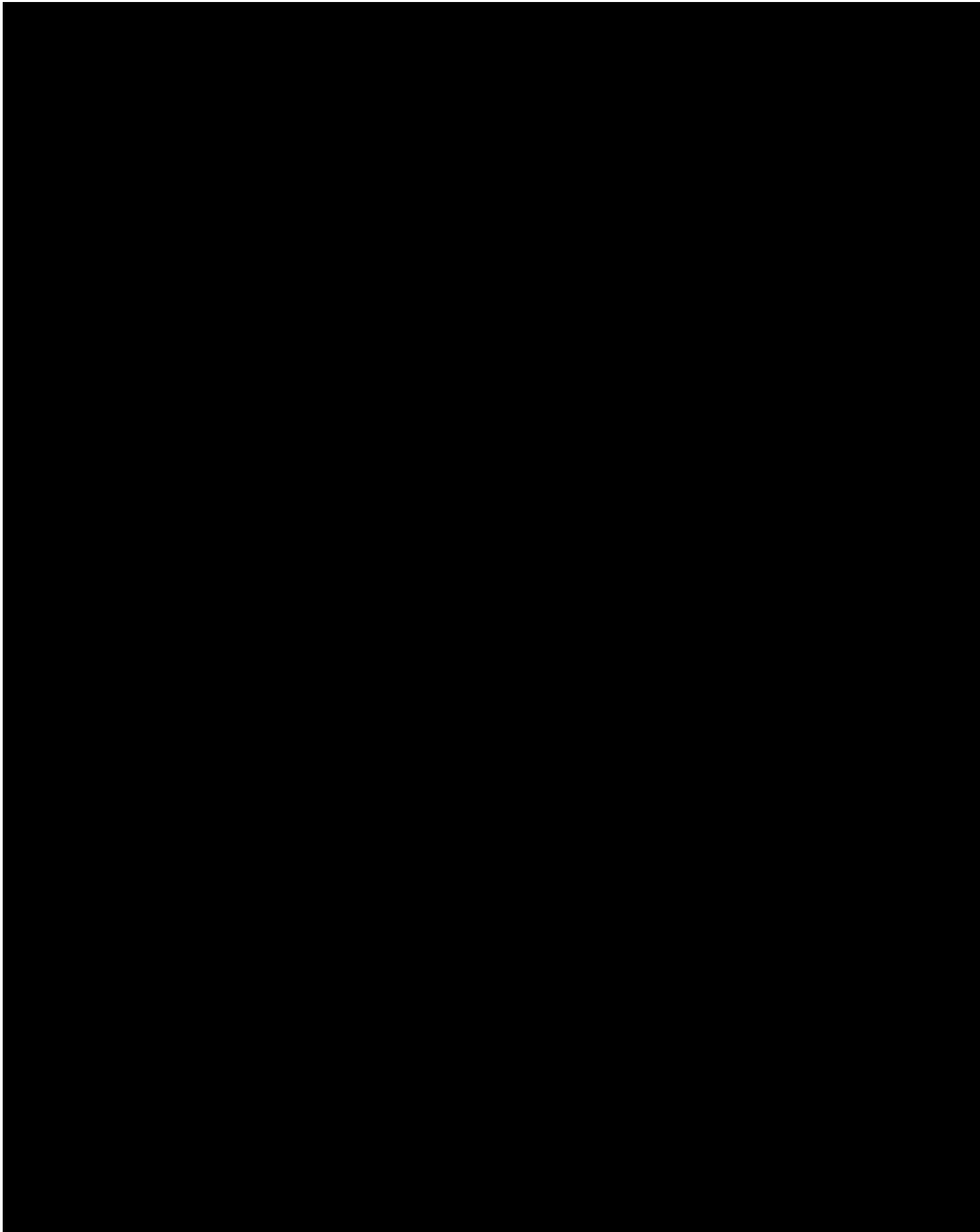

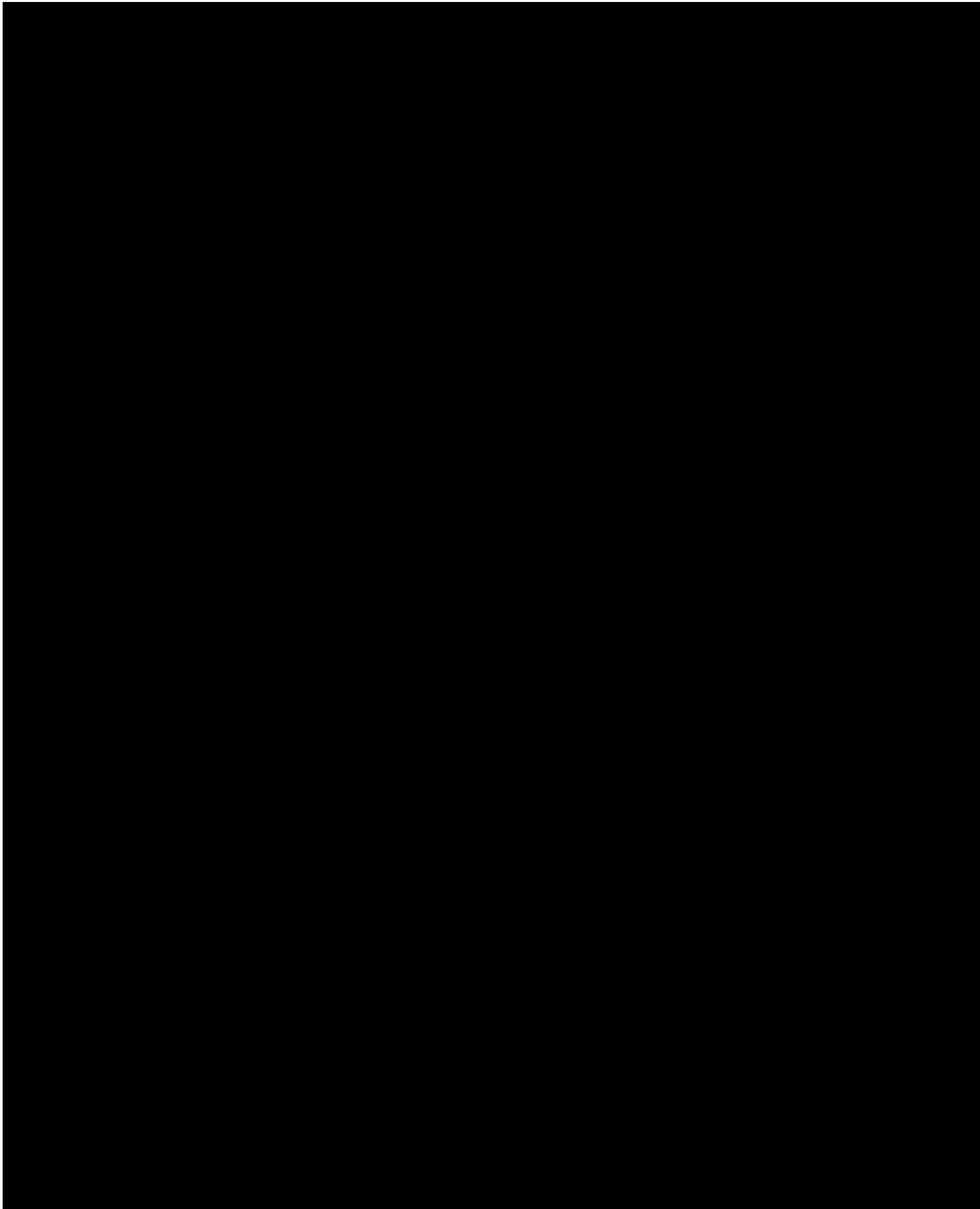

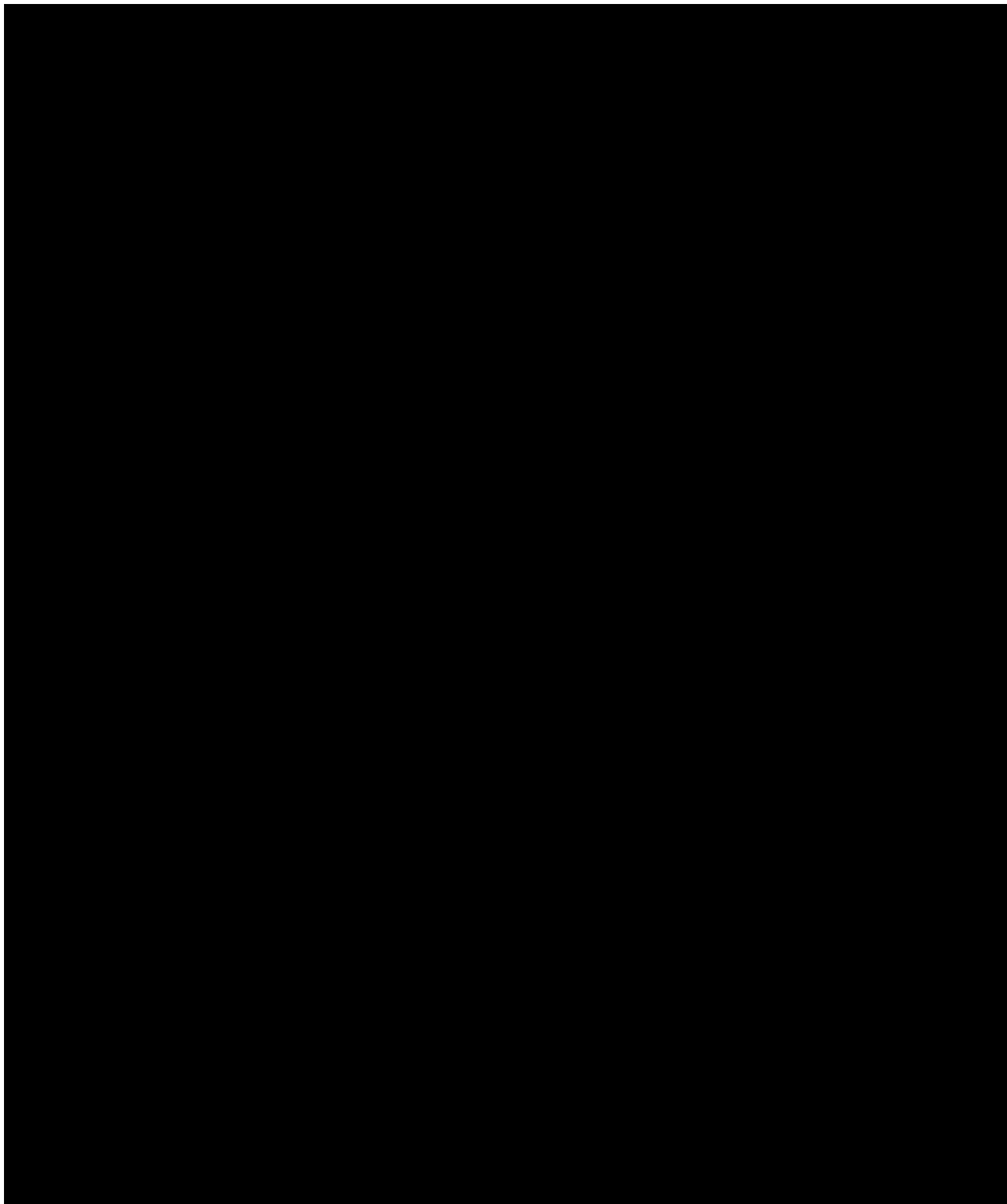

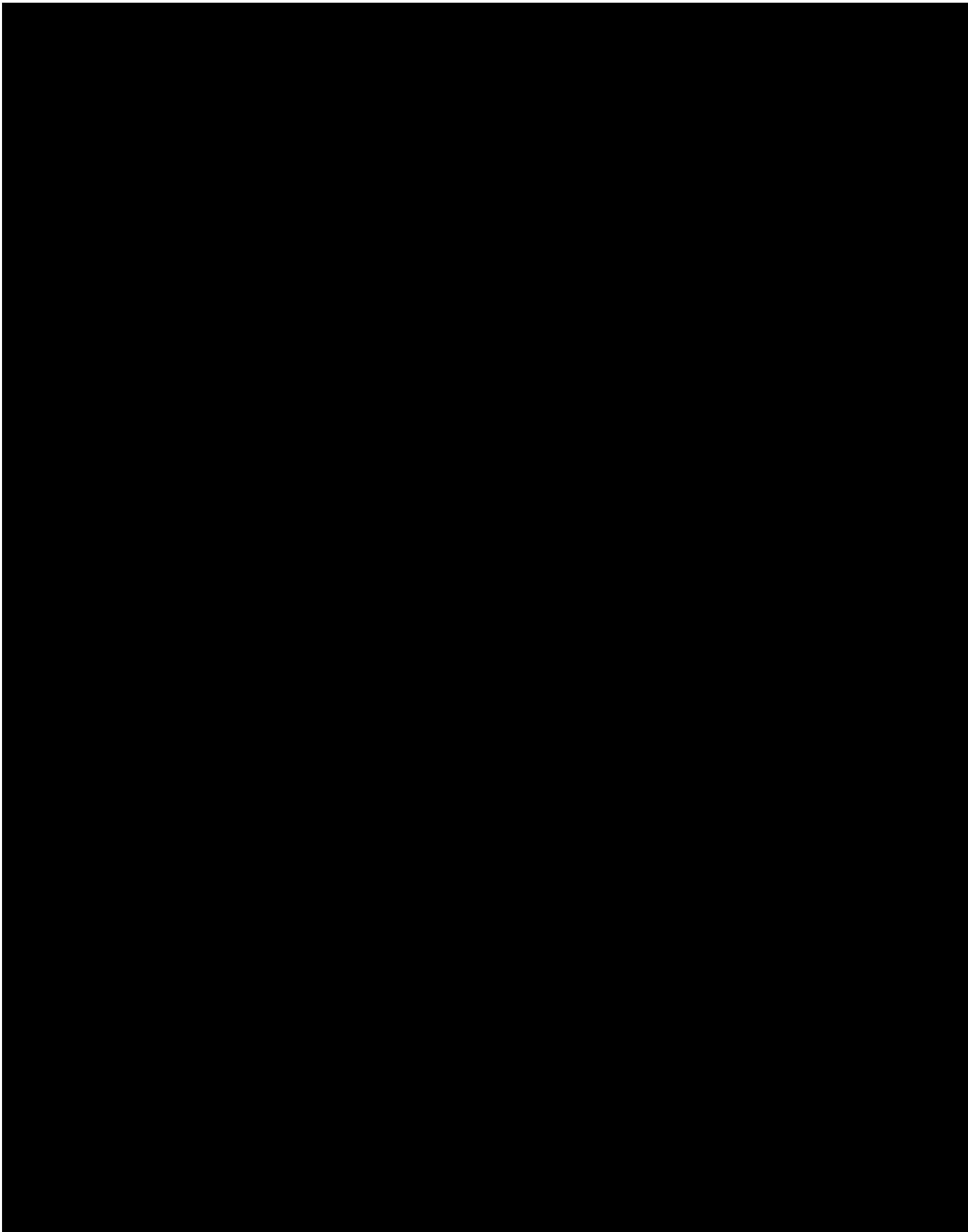

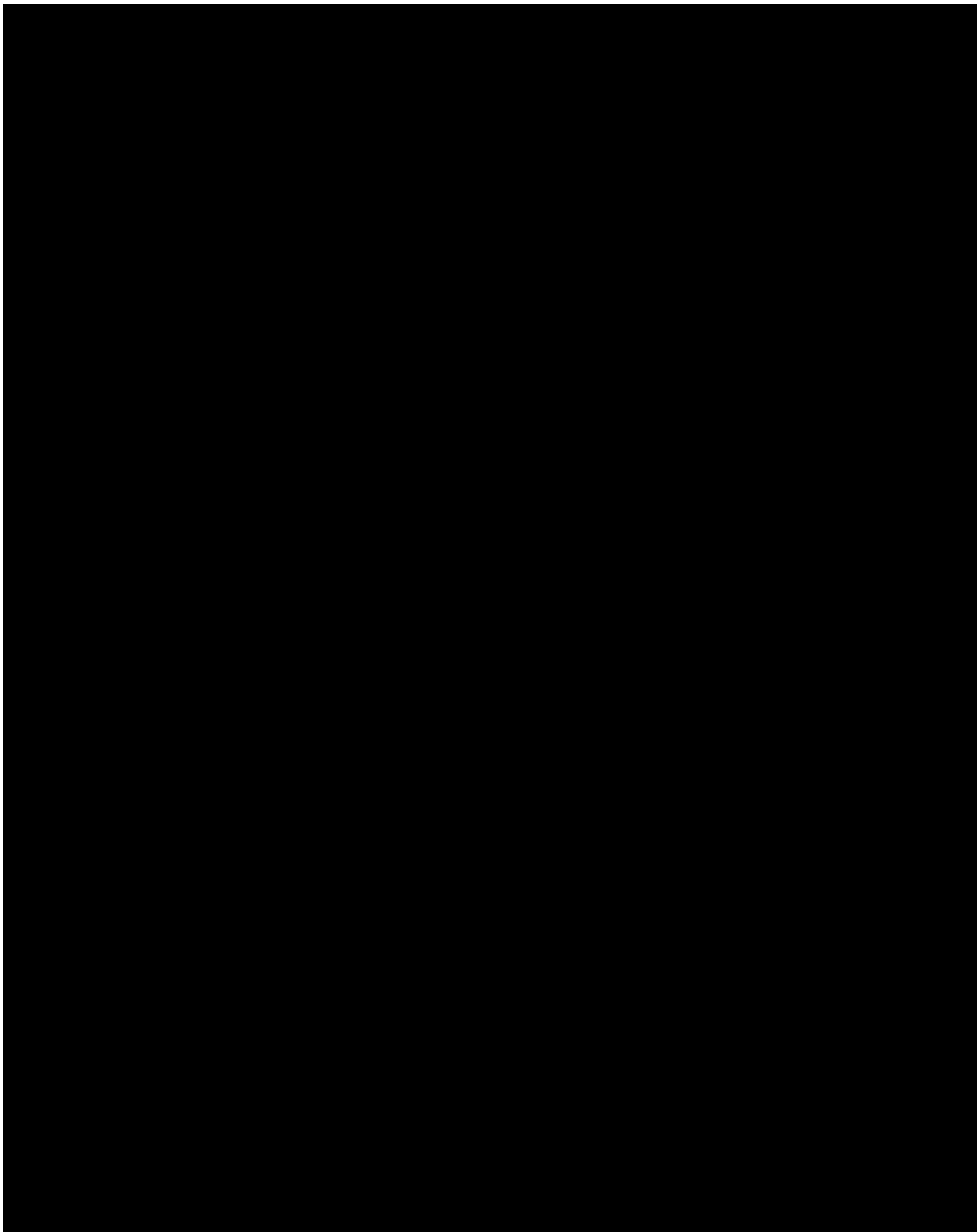

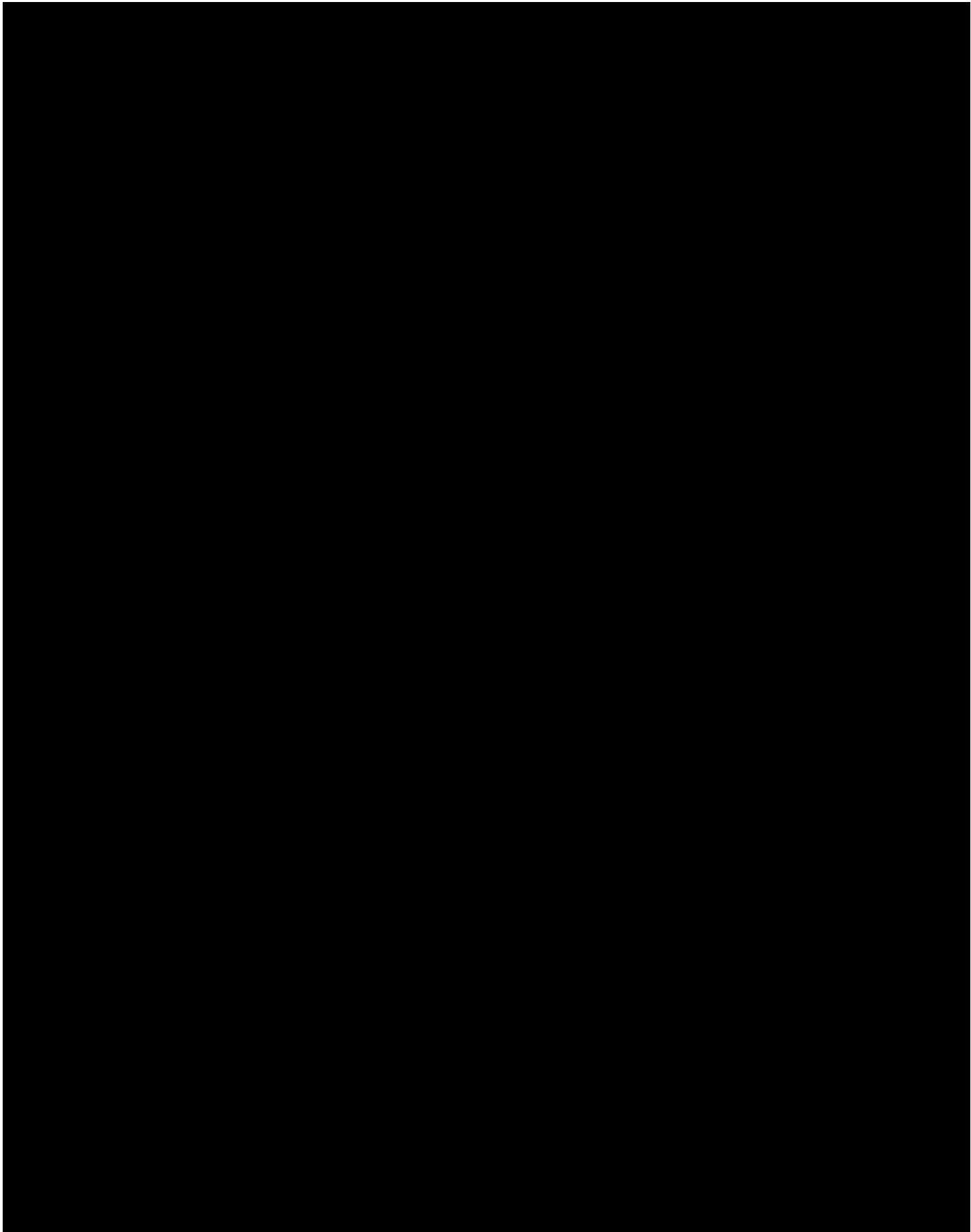

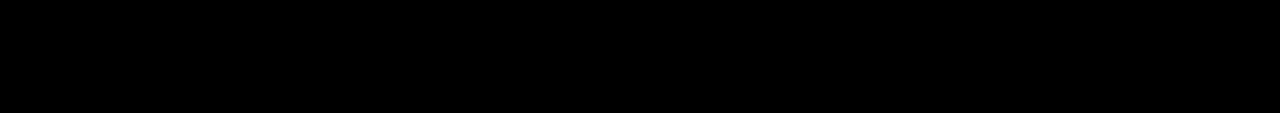

4.4 Material Selection

Casing string materials for the injection wells were selected based on the risk of corrosion. Casing constructed with alloy steel was installed in zones where there is low risk of CO₂ contact with the casing. Corrosion resistant alloy (CRA) was used in zones that will be in contact with CO₂ and formation. The primary casing below the packer and 3 to 5 joints above the packer are composed of CRA. The remainder of the well casing is alloy steel.

Appendix A discusses the material selection process.

4.5 Cement Program

To ensure long term barrier integrity under anticipated CO₂ conditions at and near the Injection Zone, modifications have been made to the slurry design(s) that improve chemical and mechanical resistance to the effects of carbonic acid exposure. These are and will be referenced as ‘CO₂ Resistant Slurries.’ The modifications, while may vary slightly due to well conditions, formation pressures and strengths, etc. all contain the following composition adjustments when compared to conventional and/or ordinary Portland cement (OPC).

Additional discussion about the cement selection and additives is in Appendix B

Table 21—Cementing Program for BRP CCS1

Section	Type	Depths (ft)	Density (ppg)	Sacks	Excess
20 in	Concrete blend	0 to 120	-	474	100%
17 ½ -in.	OPC (Ordinary Portland Cement) with additives	0 to 1,289	12.4	950	125%
	OPC (Ordinary Portland Cement) with additives	1,289 to 1,789	14.8	545	100%
12 ¼-in.	OPC (Ordinary Portland Cement) with additives	0 to 3,307	12.0	1,110	225%
	OPC (Ordinary Portland Cement) with additives	3,307 to 3,807	14.5	260	100%
8 ½ -in.	OPC (Ordinary Portland Cement) with additives	0 to 3,597	13.5	1,070	50%
	CO ₂ resistant (reduced Portland content) Class C, with additives (pozzolan, fly ash, silica sand/flour, fluid loss, and latex)	3,597 to 6,188	13.5	720	50%

Table 22—Cementing Program for BRP CCS2

Section	Type	Depths (ft)	Density (ppg)	Sacks	Excess
20 in	Concrete blend	0 to 120	-	474	100%

17 ½ -in.	OPC (Ordinary Portland Cement) with additives	0 to 1,288	12.4	950	125%
	OPC (Ordinary Portland Cement) with additives	1,288 to 1,788	14.8	545	100%
12 ¼-in.	OPC (Ordinary Portland Cement) with additives	0 to 3,297	12.0	1,110	225%
	OPC (Ordinary Portland Cement) with additives	3,297 to 3,797	14.5	320	100%
8 ½ -in.	OPC (Ordinary Portland Cement) with additives	0 to 3,565	13.5	1,045	50%
	CO ₂ resistant (reduced Portland content) class C, with additives (pozzolan, fly ash, silica sand/flour, fluid loss, and latex)	3,565 to 9,260	13.5	1,540	50%

Table 23—Cementing Program for BRP CCS3

Section	Type	Depths (ft)	Density (ppg)	Sacks	Excess
20 in	Concrete blend	0 to 120	-	474	100 %
17 ½ -in.	OPC (Ordinary Portland Cement) with additives	0 to 1,288	12.4	950	125%
	OPC (Ordinary Portland Cement) with additives	1,288 to 1,788	14.8	545	100%
12 ¼-in.	OPC (Ordinary Portland Cement) with additives	0 to 3,297	12.0	1290	225%
	OPC (Ordinary Portland Cement) with additives	3,297 to 3,797	14.5	265	100%
8 ½ -in.	OPC (Ordinary Portland Cement) with additives	0	11.5	480	0%
	OPC (Ordinary Portland Cement) with additives	0 to 3,590	13.5	707	0%
	CO ₂ resistant (reduced Portland content) class C, with additives (pozzolan, fly ash, silica sand/flour, fluid loss, and latex)	3,590 to 6,554	13.5	820	50%

4.6. Mud Program

Table 24--Mud Program for BRP CCS1

Hole	Type	Depths (ft)	Density (ppg)	PV (cP)	YP (lbm/100 ft ²)	Funnel Viscosity (sec)	API Fluid Loss (cm ³)	LGS (%)
17 ½ -in	Fresh water gel	0 to 1,804	8.5 to 9.5	12 to 14	14 to 18	40 to 50	<20	<8

12 ¼-in	Fresh gel mud/ Brine water inhibited	0 to 3,822	9.5 to 10.2	14 to 18	16 to 18	40 to 50	<6	<3
8 1/2-in	Brine water inhibited	3,822 to 6,218	9.5 to 10.2	14 to 18	16 to 18	40 to 50	<6	<3

Table 25--Mud Program for BRP CCS2

Hole	Type	Depths (ft)	Density (ppg)	PV (cP)	YP (lbm/100 ft ²)	Funnel Viscosity (sec)	API Fluid Loss (cm ³)	LGS (%)
17 ½ - in	Fresh water gel	0 to 1,803	8.5 to 9.5	12 to 14	14 to 18	40 to 50	<20	<8
12 ¼-in	Fresh gel mud/ Brine water inhibited	0 to 3,811	9.5 to 10.2	14 to 18	16 to 18	40 to 50	<6	<3
8 1/2-in	Brine water inhibited	3,811 to 9,312	9.5 to 10.2	14 to 18	16 to 18	40 to 50	<6	<3

Table 26--Mud Program for BRP CCS3

Hole	Type	Depths (ft)	Density (ppg)	PV (cP)	YP (lbm/100 ft ²)	Funnel Viscosity (sec)	API Fluid Loss (cm ³)	LGS (%)
17 ½ - in	Fresh water gel	0 to 1,803	8.5 to 9.5	12 to 14	14 to 18	40 to 50	<20	<8
12 ¼-in	Fresh gel mud/ Brine water inhibited	0 to 3,891	9.5 to 10.2	14 to 18	16 to 18	40 to 50	<6	<3
8 1/2-in	Brine water inhibited	3,891 to 6,598	9.5 to 10.2	14 to 18	16 to 18	40 to 50	<6	<3

5.0 Data Acquisition and Testing Plan Summary

Comprehensive details on pre-operational testing are provided in the Pre-Operational Testing Plan that is part of this application. The information below summarizes key components of the plan.

The pre-operational testing program determined or verified the depth, thickness, mineralogy, lithology, porosity, permeability, and geomechanical information of the Injection Zone, the overlying Upper Confining Zone, and other relevant geologic formations. In addition, formation fluid characteristics of the Injection Zone were obtained to establish baseline data against which future measurements may be

compared after the start of injection operations. Section 5.0 lists the wireline logs and tests conducted for the BRP CCS1, BRP CCS2, and BRP CCS3. Consult Table 14 of the Pre-Operations Plan or Table 6 in the QASP for details on fluid analyses.

Table 27— Open hole logs acquired during the construction phase of BRP CCS1

Method	Interval Section(s)	Purpose
Deviation survey	Every 100 ft while drilling as minimum, from surface to TD	Define well trajectory, displacement, and tortuosity
Wireline – Spontaneous Potential	Surface, Intermediate, Production	Correlation log, volume of shale indicator, estimate salinity
Wireline – Resistivity	Surface, Intermediate, Production	Fluid identification, estimate salinity, correlation log
Wireline – Caliper	Surface, Intermediate, Production	Identify borehole enlargement and calculate cement volume
Wireline – Gamma ray	Intermediate, Production	Define stratigraphy, correlation log, shale indicator
Wireline – Magnetic resonance image	Production	Estimate porosity, pore size distribution, permeability index
Wireline – Sonic Scanner	Intermediate, Production	Estimate mechanical properties, validation of velocity model, well tie to seismic
Wireline – Spectral gamma ray	Surface, Intermediate, Production	Define uranium-rich formation, clay indicator
Wireline – Density / neutron	Surface, Intermediate, Production	Estimate porosity, mineralogical characterization
Wireline – High-definition image	Production	Identify fracture, structural information, minimum stress orientation
Wireline – Litho-scanner or equivalent	Production	Identify mineralogy
Wireline – Formation Dynamics Testing	Production	Measure formation pressures, fluid sampling, mini-frac testing
Mud Logging	Surface to TD (every 30 ft)	Identify lithology, hydrocarbon shows, gases composition

Table 28--Cased hole logs acquired during the drilling and completion phases of BRP CCS1.

Method	Interval Section(s)	Purpose
Cased Hole Logs and surveys Before Injection		
Wireline – CBL-VDL-CCL	Surface, Intermediate	Cement bond, Validate external mechanical integrity
Wireline – CBL-VDL-USIT (Casing inspection log)-CCL	Production	Cement bond, casing inspection log (USIT); Validate external mechanical integrity
Annulus Pressure Test – Long string casing	Annular between tubing and long string	Validate internal mechanical integrity between the tubing, long-string, and packer
Wireline – Activate pulsed neutron (Oxygen Activation Log) – Long string casing	Surface, Intermediate, Production	CO ₂ saturation, baseline for monitoring
Wireline – Temperature Log	Surface, Intermediate, Production	Measure baseline temperature profile on the well from surface to top of perforation
Fiber Optic – DAS, DTS survey	Surface, Intermediate, Production.	Measure baseline temperature profile on the well from surface to top of perforation Acquire baseline 3D VSP survey for monitoring plume migration over time

Table 29-- Open hole logs acquired during the construction phase of BRP CCS2.

Method	Interval Section(s)	Purpose
Deviation survey	Every 100 ft while drilling as minimum, from surface to TD	Define well trajectory, displacement, tortuosity
Wireline – Spontaneous Potential	Surface, Intermediate	Correlation log, volume of shale indicator, estimate salinity
Wireline – Resistivity	Surface, Intermediate, Production	Fluid identification, estimate salinity, correlation log
Thru-bit – Resistivity	Production	Fluid identification, estimate salinity, correlation log
Wireline – Caliper	Surface, Intermediate	Identify borehole enlargement and calculate cement volume
Thru-bit – Caliper	Production	Identify borehole enlargement and calculate cement volume
Wireline – Gamma ray	Surface, Intermediate	Define stratigraphy, correlation log, shale indicator
Thru-bit – Gamma ray	Production	Define stratigraphy, correlation log, shale indicator
Wireline – Sonic Scanner	Intermediate	Estimate mechanical properties, validation of velocity model, well tie to seismic
Thru-bit – Dipole Sonic	Production	Estimate mechanical properties, validation of velocity model, well tie to seismic
Wireline – Spectral gamma ray	Surface, Intermediate	Define uranium-rich formation, clay indicator

Method	Interval Section(s)	Purpose
Thurbit – Spectral gamma ray	Production	Define uranium-rich formation, clay indicator
Wireline – Density / neutron	Surface, Intermediate	Estimate porosity, mineralogical characterization
Thurbit – Density / neutron	Production	Estimate porosity, mineralogical characterization
Thurbit – High-definition image	Production	Identify fracture, structural information, minimum stress orientation
Thurbit – Litho-scanner or equivalent (Pulsar)	Production	Identify mineralogy
Wireline and TLC – Formation Dynamics Testing	Production	Measure formation pressures, fluid sampling, mini-frac testing
Mud Logging	Surface to TD (every 30 ft)	Identify lithology, hydrocarbon shows, gases composition

Table 30-- Cased hole logs acquired during the drilling and completion phases of BRP CCS2.

Method	Interval Section(s)	Purpose
Cased Hole Logs and surveys Before Injection		
Wireline – CBL-VDL- CCL	Surface, Intermediate	Cement bond, Validate external mechanical integrity
Wireline – CBL-VDL-USIT (Casing inspection log)-CCL	Production	Cement bond, casing inspection log (USIT); Validate external mechanical integrity
Annulus Pressure Test – Long string casing	Annular between tubing and long string	Validate internal mechanical integrity between the tubing, long-string, and packer
Wireline – Activate pulsed neutron (Oxygen Activation Log) – Long string casing	Surface, Intermediate, Production	CO ₂ saturation, baseline for monitoring
Wireline – Temperature Log	Surface, Intermediate, Production	Measure baseline temperature profile on the well from surface to top of perforation
Fiber Optic – DAS, DTS survey	Surface, Intermediate, Production	Measure baseline temperature profile on the well from surface to top of perforation Acquire baseline 3D VSP survey for monitoring plume migration over time

Table 31--Open hole logs acquired during the construction phase of BRP CCS3.

Method	Interval Section(s)	Purpose
Deviation survey	Every 100 ft while drilling as minimum, from surface to TD	Define well trajectory, displacement, tortuosity
Wireline – Spontaneous Potential	Surface, Intermediate, Production	Correlation log, volume of shale indicator, estimate salinity
Wireline – Resistivity	Surface, Intermediate, Production	Fluid identification, estimate salinity, correlation log

Method	Interval Section(s)	Purpose
Wireline – Caliper	Surface, Intermediate, Production	Identify borehole enlargement and calculate cement volume
Wireline – Gamma ray	Surface, Intermediate, Production	Define stratigraphy, correlation log, shale indicator
Wireline – Magnetic resonance image	Production	Estimate porosity, pore size distribution, permeability index
Wireline – Sonic Scanner	Intermediate, Production	Estimate mechanical properties, validation of velocity model, well tie to seismic
Wireline – Spectral gamma ray	Surface, Intermediate, Production	Define uranium-rich formation, clay indicator
Wireline – Density / neutron	Surface, Intermediate, Production	Estimate porosity, mineralogical characterization
Wireline – High-definition image	Production	Identify fracture, structural information, minimum stress orientation
Wireline – Litho-scanner or equivalent	Production	Identify mineralogy
Wireline – Formation Dynamics Testing	Production	Measure formation pressures, fluid sampling, mini-frac testing
Mud Logging	Surface to TD (every 30 ft)	Identify lithology, hydrocarbon shows, gases composition

Table 32-- Cased hole logs acquired during the drilling and completion phases of BRP CCS3.

Method	Interval Section(s)	Purpose
Cased Hole Logs and surveys Before Injection		
Wireline – CBL-VDL- CCL	Surface, Intermediate	Cement bond, Validate external mechanical integrity
Wireline – CBL-VDL-USIT (Casing inspection log)-CCL	Production	Cement bond, casing inspection log (USIT); Validate external mechanical integrity
Annulus Pressure Test – Long string casing	Annular between tubing and long string	Validate internal mechanical integrity between the tubing, long-string, and packer
Wireline – Activate pulsed neutron (Oxygen Activation Log) – Long string casing	Surface, Intermediate, Production	CO ₂ saturation, baseline for monitoring
Wireline – Temperature Log	Surface, Intermediate, Production	Measure baseline temperature profile on the well from surface to top of perforation
Fiber Optic – DAS, DTS survey	Surface, Intermediate, Production	Measure baseline temperature profile on the well from surface to top of perforation Acquire baseline 3D VSP survey for monitoring plume migration over time

In addition to the logging and testing listed above, OLCV performed mini-fracs in distinct porosity / permeability packages within the proposed Injection Zone and Upper and Lower Confining Zones. Thin

intervals that were interpreted to have limited horizontal extent were not tested. The interval for mini-frac was selected following a review of logging data. The Fracture Propagation Pressure was interpreted by qualified OLCV reservoir and completions engineers to determine injection limits throughout the Injection Zone.

OLCV measured reservoir pressures and acquired fluid samples in the Injection Zone. Based on data from the Shoe Bar 1 and Shoe Bar 1AZ, OLCV anticipated encountering three distinct porosity zones. OLCV collected fluid samples in each of these porosity zones. The sampling depths were selected after reviewing logging data. The fluid and dissolved gas samples were transported under pressure to a third-party lab for comprehensive analysis. See Section 5.1 of Appendix B Baseline report to the Pre-Operations Plan for fluid and dissolved gas results. Fluid level testing was conducted following well completion. The test measured static fluid level using an echometer.

An injectivity test was performed in the Injection Zone after well completion and installation of the tubing and packer. The pre-operation injectivity testing is a baseline for future pressure fall-off testing. The purpose of injectivity testing was to verify or establish the injection well operating parameters and constrain the inputs used for dynamic injection simulation modeling. See section 4.1.12, 4.2.12, and 4.3.12 of Appendix B Baseline report to the Pre-Operations Plan for details on injectivity testing procedures.

OLCV submitted the pre-injection procedures for logging, sampling, and testing to the Program Director 30 days prior to performing the first test, as required by 40 CFR §146.87.

6.0 Demonstration of Mechanical Integrity and Baseline for Monitoring

Table 33 below summarizes the tests that were conducted in the UIC Class VI injection well to prove mechanical integrity.

Table 33—Summary of Pre-Injection Testing at Injection Well Site

Test	Purpose
Annulus pressure test	MIT – Internal
Temperature and pressure log	MIT – External
Ultrasonic Inspection Tool Log	MIT – External
Casing Pressure Test	MIT - Internal
Injectivity and Pressure fall-off test	Injection Zone properties
Pulsed Neutron Log	Baseline for CO ₂ saturation
Cement Bond Log, Variable Density Log	Casing and Cement verification

7.0 Blowout Preventer and Wellhead Requirements

The criteria below describe how well equipment for the UIC Class VI wells was selected.

7.1 Blowout Preventer Equipment (BOPE)

- BOPE shall be API-monogrammed and adhere to API Standard 53 and Specifications 16A and 16C at a minimum and shall meet or exceed all applicable regulatory specifications.
- BOPE other than annular preventers shall have a minimum working pressure exceeding the maximum anticipated surface pressure (MASP).
- All BOPE stacks shall incorporate a set of blind rams.
- Blind rams shall be located in the lower ram cavity of a two-ram stack or the middle ram cavity of a three-ram stack.
- Choke and kill line outlets shall be located below the blind rams on either a two-ram or three-ram stack.
- All rigs shall have a calibrated trip tank. The trip tank and trip sheet are used to measure the fluid required to fill or displace fluid from the hole during all tripping operations, including when running the casing or completion string. Trip sheets shall include the number of joints or stands run into or pulled from the hole vs. the calculated and actual displacements per step and a running total as a minimum.
- A full-opening safety valve (FOSV) and an inside-BOP safety valve (IBOPSV) shall be always available on the rig floor for each drill pipe and drill collar size and connection type in use. The FOSV is used to stab into the string and shut off flow through the drill string. The IBOPSV is used above the FOSV to prevent backflow through the drill string. These valves shall remain in the fully open position until installed. **Note:** This requirement is in addition to any integral safety valve in the top drive system inclusive of casing running operations. In the event of a power failure on a variable frequency drive (VFD) rig, it is impossible to slack off and make up the top drive to the string; therefore, there is a need for additional independent stabbing valve(s) to be available on the floor always.
- If a wireline lubricator is utilized for wireline operations, it shall not be the type that slips into and is held by the annular preventer or rams. A hydraulic cutter or other means of safely cutting the wireline shall be available if a lubricator is not in use.
- Pressure-energized metal ring gaskets shall be used on flanged well-control equipment. These gaskets shall not be reused on equipment that will be nipped-up on the wellbore.

7.2 Choke Manifolds and Kill Line

- The choke manifold shall be API-monogrammed, meet API SPEC 16C as a minimum, and meet or exceed all applicable regulatory specifications.
- All BOPE shall include a choke manifold with at least one remotely operated choke and one manual choke installed. The control panel shall contain calibrated drill pipe and casing pressure gauges that shall be both accurate and properly maintained. The choke manifold casing pressure should have the capability of being recorded on the drilling rig's recorder. If necessary, for clear dialogue, an

electronic means of direct communication with the driller should be in place. This equipment shall be tested and its calibration checked at each casing shoe and at every BOPE test, and results shall be logged on every BOPE test report.

- Flare / vent lines shall be as long as practical, a minimum of 150 ft from the well center, as straight as possible, without sumps, collection areas, or uphill flow areas (to prevent fluid buildup and resulting backpressure) and shall be securely anchored.

7.3 Closing Units

- BOPE closing units shall adhere to API Spec 16D and API STD 53 as a minimum and meet or exceed all applicable regulatory specifications.
- BOPE control systems shall include full controls on the closing unit and at least one remote control station. One control station shall be located within 10 ft of the driller's console.
- BOPE closing units shall have two separate charging pumps with two independent power sources, as specified in API Spec 16D, or have nitrogen bottle backup.
- When pumps are inoperative, BOPE closing units shall have sufficient usable hydraulic fluid volume to close one annular preventer, close all ram preventers, and open one HCR valve against zero wellbore pressure with 200 psi remaining pressure above the pre-charge pressure.

7.4 Pressure Testing

- BOPE components (including the BOP stack, choke manifold, and choke lines) shall be pressure tested at the following frequency:
 - When installed. If the BOPE is stump tested, only the new connections are required to be tested at installation.
 - Before 21 days have elapsed since the last BOPE pressure test. When the 21-day test is due soon, consider testing the BOPE prior to drilling H₂S, abnormal pressure, or any lost return zones to avoid having to test while drilling these intervals.
 - Anytime a BOPE connection seal is broken, the connection shall be pressure tested after reassembly and before use.
 - When utilizing tapered strings, variable bore-type rams and annular preventers shall be pressure tested with all tubing or drill pipe sizes anticipated to be used.
- BOPE shall be tested using a test plug or other means to isolate the casing and open hole from the test pressures. The casinghead valve shall be opened and monitored to avoid exerting BOPE test pressure on the casing or open hole.
- BOPE components shall first be low-pressure tested to between 250 and 350 psi. If the pressure exceeds 350 psi during this test, the pressure shall be bled off to 0 psi and the test restarted. Pressuring up beyond 350 psi can induce a seal and give a false test result.

- BOPE components, excluding the annular preventer, shall be tested to the lesser of rated working pressure (RWP) or wellhead RWP if less than BOPE RWP. The annular preventer shall be tested to 70% of its RWP. In all cases, the test pressure shall not exceed the RWP of any of the components being tested.
- Use of a cup tester should be avoided. If a cup tester is utilized for BOP testing, consideration shall be given to casing burst pressure and possible pressure applied to the casing string or open hole below the cup tester in the event of a leaking cup tester.
- An accumulator closing test shall be performed after the initial nipple-up of the BOP, after any repairs that required isolation or partial isolation of the system, or at initial nipple-up on each well.
- During drilling, the pipe rams shall be functionally operated at least once every 24 hours. The blind rams shall be functionally operated each trip out of the wellbore.

7.5 Wellhead Schematic

Figure 8 below is a schematic diagram of the wellhead to be used for the BRP CCS1, BRP CCS2 and BRP CCS3 wells.

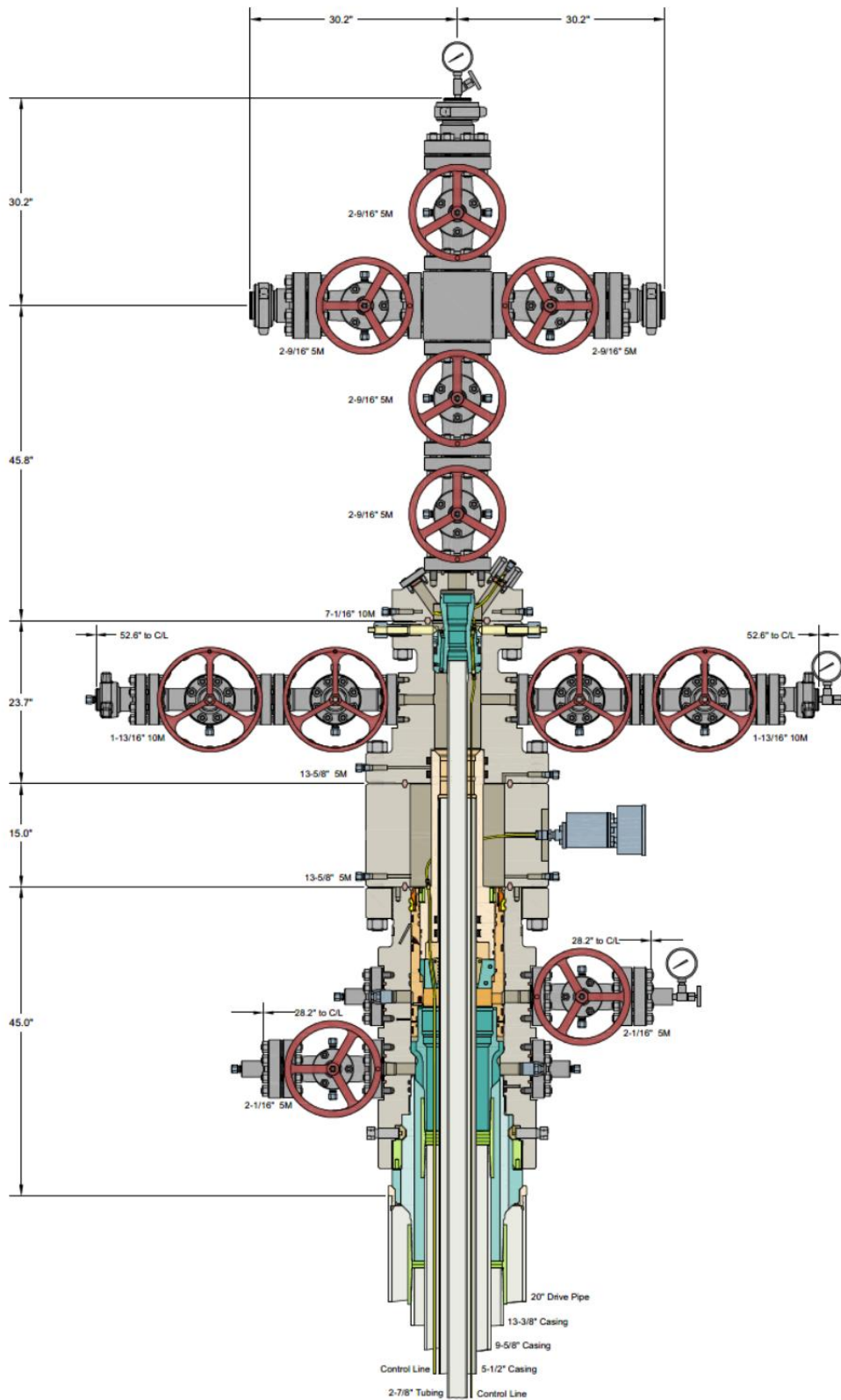

Figure 8—Schematic diagram of the wellhead used on UIC Class VI wells

C. STIMULATION PLAN

**INJECTION WELL STIMULATION PLAN
40 CFR 146.82(a)(9)**

BRP CO₂ Sequestration Project

INJECTION WELL STIMULATION PLAN 40 CFR 146.82(a)(9)..... 1
1.0 Facility Information 1
2.0 Introduction and Purpose 1
 2.1 Purpose of Stimulation..... 2
3.0 Stimulation Fluids..... 2
 3.1 Additives..... 3
 3.2 Diverters..... 3
4.0 Mechanical Stimulation 3
5.0 Ensuring Containment 4
6.0 Standard Stimulation Procedure 4
7.0 References..... 5

1.0 Facility Information

Facility name: Brown Pelican CO₂ Sequestration Project
BRP CCS 1, 2 and 3 Wells

Facility contact: 

Well location: Penwell, Texas

BRP CCS1	31.76479314	-102.7289311
BRP CCS2	31.76993805	-102.7332448
BRP CCS3	31.76031163	-102.7101566

2.0 Introduction and Purpose

Oxy Low Carbon Ventures (OLCV) may stimulate the injection zone for the Brown Pelican (BRP) Project to enhance the injectivity potential of CO₂ injection wells and the productivity of water withdrawal wells. Stimulation may involve, but is not limited to, flowing fluids into or out of the

well, increasing or connecting pore spaces in the injection/production formation, or other activities that are intended to allow CO₂ to move more readily into the injection zone and for the water to be more efficiently produced.

OLCV will adhere to all applicable regulatory requirements for any stimulation treatment that may be required. Specifically, and without limitation, OLCV will comply with the following:

- 40 CFR 146.82(a)(9): OLCV will submit the proposed stimulation program, a description of stimulation fluids to be used and a determination that stimulation will not interfere with containment.
- 40 CFR 146.88(a): Except during stimulation, OLCV will ensure that injection pressure does not exceed 90 percent of the fracture pressure of the injection zone(s) so as to ensure that the injection does not initiate new fractures or propagate existing fractures in the injection zones(s). In no case will injection pressure initiate fractures in the confining zones(s) or cause movement of injection or formation fluids that endanger a USDW.
- 40 CFR 146.91(d)(2) and (e): OLCV will notify the Director in writing 30 days in advance of any planned stimulation activities, other than stimulation for formation testing conducted under 40 CFR 146.82. Regardless of whether a state has primary enforcement responsibility, OLCV shall submit all required reports, submittals, and notifications under subpart h of this part to EPA in an electronic format approved by EPA.

The information provided in this section specifically addresses the stimulation fluids, additives, and proposed stimulation procedures OLCV may implement. This plan includes multiple stimulation methodologies that may be selected based on site-specific technical and operational conditions that may impact future well performance. The methods provided below may also be used to remediate scaling or perforation occlusion in the well.

2.1 Purpose of Stimulation

Perforated intervals in the Lower San Andres CO₂ injection / water production zone may require stimulation periodically throughout the project life to enhance performance with the aim to restore it to initial or optimum conditions. For example, stimulation may be needed to remediate injectivity loss resulting from mineral scales, clay fragments, metallic sulfide, or oxide particulates. Stimulation may also be necessary to remove any near-wellbore damage resulting from drilling and completion operations. Following well construction, remedial stimulation may be conducted before the commencement of CO₂ injection or water withdrawal.

3.0 Stimulation Fluids

At BRP, OLCV will use acid blends for matrix stimulation that are typical for the industry. These include, but are not limited to, mixtures of acetic, hydrochloric, hydrofluoric, and/or other organic acids. These blends have been historically proven to remove near-wellbore damage caused by

mineral scales, drilling muds, completion fluids, and clay fines while minimizing negative impacts to permeability. There is also a potential for near-wellbore halite precipitation in the CO₂ injectors, which may require remediation by periodic flushes with less saline water.

All chemical treatments will be evaluated and selected for compatibility with the treatment method. For example, mineral acids will be treated with chemical inhibitors to prevent corrosion damage to the tubing string. In addition, chemical systems will be evaluated and selected to avoid damage to the down hole packer sealing elements, casing, and other seals within the injection system that might be exposed to the chemicals.

3.1 Additives

Additives may be utilized with the stimulation fluids to aid matrix stimulation while mitigating corrosion of tubulars and potential damage to the sequestration zone. These additives include, but are not limited to, corrosion or acid inhibitors, scale inhibitors, clay stabilizers, biocides, demulsifiers, chelating agents, mutual solvents, iron sequestrants, retarders, and/or surfactants. Compatibility of these additives with the stimulation fluids, tubulars and the reservoir will be confirmed prior to their use in any stimulation activities.

3.2 Diverters

Nitrogen or CO₂ may be added to stimulation fluids to achieve improved diversion and effective treatment for the target zone by diverting the stimulation fluids to the most impaired (*i.e.*, low injectivity/productivity) perforations. Depending on the well-specific requirements and stimulation design, organic or polymeric diverting agents may also be selected. These diverters provide temporary restrictions during stimulation operations and degrade or break-down with time due to water solubility and temperature.

The most suitable diverting agent will be selected based on one or more factors, including, anticipated pump rates, the length of the perforated interval, perforation density, and the selected technique for conveying acid to the injection zone (*e.g.*, pumping through regular tubing or pumping down coiled tubing).

4.0 Mechanical Stimulation

In addition to chemical stimulation, mechanical stimulation of the well may be required independently, or in conjunction with chemical stimulation. Mechanical stimulation may be required if there is deposition that cannot be easily remediated with chemicals, or if mechanical means may be more effective. These mechanical options include, but are not limited to, backflow, adding perforations, or re-perforating. Perforating operations may be further enhanced with the use of propellants. Propellant stimulations will be designed for nominal height growth, and to

remain within the injection zone and avoid fracture growth into the confining layer (Wieland, 2006).

5.0 Ensuring Containment

Except during stimulation, injection pressure will not exceed 90% of the established fracture pressure for the injection zone. Injection pressure at the downhole tubing pressure gauge and tubing/annulus surface gauges will be continuously monitored during the stimulation operation.

Stimulation of the injection interval will be conducted to avoid affecting the confining layers. Perforations in the injection zone will be vertically separated from the base of the confining layers by a minimum of 10 feet. Chemicals injected into perforations in the injection zone will not come into contact with the confining layers.

6.0 Standard Stimulation Procedure

If injection rates decline below expected values at any time during the project life, OLCV may investigate the cause to determine whether stimulation may be required. Investigation activities may include, without limitation, the following:

- Logging operations, including but not limited to, evaluation of the injection/production profile, mechanical spinner surveys, caliper logging, downhole camera investigation, etc.
- Collecting downhole samples when necessary or feasible with wireline, slickline or coiled tubing conveyed sampling equipment, to be followed by analytical testing as appropriate to determine remediation options.

A standard stimulation procedure is outlined below. This procedure may be modified depending on site-specific operational and technical conditions and the specific treatment requirements. The conveyance methods may include coil tubing, tubing-conveyed retrievable straddle packer assembly, snubbing unit, tubing flush, or bullheading.

1. Test the potential stimulation fluids blends for compatibility with well materials, reservoir rock, and fluids.
2. Design the stimulation program.
3. Provide the recommended work procedure and stimulation program to the UIC Program Director in writing at least 30-days prior to the planned date for start of the work (40 CFR 146.91(d)(2)).
4. Perform pre-job planning.
5. Discuss job safety and monitoring assignments.
6. Prepare the location for rig up of stimulation equipment.
7. Shut-in the injection or water withdrawal well, allowing the pressures to stabilize at the well and for other wells and the facility to absorb rate and pressure changes.

Plan revision number: 1
Plan revision date: 09/20/2023

8. Rig up the stimulation well intervention equipment.
9. Prepare the well for stimulation.
10. Perform the matrix stimulation as specified in this plan.
11. Flush the wellbore with treated water and prepare the well to return to normal operation.
12. Rig down and return the well back to injection or water production.

A similar procedure would be utilized for flowbacks with prior operation-specific planning for well control as well as other job-specific safety and environmental protection control practices.

7.0 References

Wieland, C. W., Miskimins, J. L., Black, A. D., and S. J. Green. "Results of a Laboratory Propellant Fracturing Test in a Colton Sandstone Block." Paper presented at the SPE Annual Technical Conference and Exhibition, San Antonio, Texas, USA, September 2006.

D. PRE-INJECTION / PRE-OPERATION TESTING PLAN

**PRE-OPERATIONAL PLAN
40 CFR §146.82**

Brown Pelican CO₂ Sequestration Project

CONTENTS

PRE-OPERATIONAL PLAN 40 CFR §146.82..... 1

1. Introduction / Purpose.....3

 1.1 Overview of Logging Suite(s)..... 6

2. Stratigraphic Wells.....8

 2.1 Overview of Stratigraphic Wells 8

 2.2 Logging Program in Stratigraphic Wells..... 8

 2.3 Coring Program 11

 2.4 Formation Fluid Characterization Program..... 12

 2.5 Fracture Pressure 14

3. Injection Wells – Pre-Op Strategy15

 3.1 Logging Program..... 15

 3.2 Coring Program 16

 3.3 Well Mechanical Integrity Testing (MIT)..... 18

 3.4 Cement Logs..... 19

 3.5 Fracture Pressure 20

 3.6 Injection Well Testing 22

 3.7 Pressure Fall-Off Testing..... 23

 3.8 Injection Wells Directional Survey 25

 3.9 Injection Wells Formation Pressure and Fluid Sampling..... 26

 3.10 Temperature logging..... 30

 3.11 Oxygen activation logging..... 31

 3.12 Fluid level testing 32

4. SLR Monitoring Wells – Pre-Op Strategy.....32

 4.1 Logging Program..... 33

 4.2 Coring Program 34

4.3 Formation Fluid Characterization Program	34
4.4 Fracture Pressure	37
4.5 Well Mechanical Integrity	38
5. USDW Monitoring Well.....	38
5.1 Logging Program.....	39
5.2 Formation Fluid Characterization Program.....	39
5.3 Well Mechanical Integrity	42
6. Water Withdrawal Wells.....	42
6.1 Logging Program.....	43
6.2 Coring Program	43
6.3 Formation Fluid Characterization Program.....	44
6.4 Fracture Pressure	44
6.3 Well Mechanical Integrity	44
7. References.....	45

Plan revision number: 3
Plan revision date: 07/30/2024

Facility name: Brown Pelican CO₂ Sequestration Project
BRP CCS1, BRP CCS2 and BRP CCS3 Wells

Facility contact:



Well location: Penwell, Texas

BRP CCS1	31.76479314	-102.7289311
BRP CCS2	31.76993805	-102.7332448
BRP CCS3	31.76031163	-102.7101566

1. Introduction / Purpose

The Brown Pelican CO₂ Sequestration Project (BRP Project or Project) includes participation of multidisciplinary teams from Occidental Oil & Gas Corporation (Oxy), parent company of Oxy Low Carbon Ventures (OLCV) consultants, and subcontractors. Each team will provide technical expertise and economic inputs to the Project to ensure a safe, successful, and efficient operation.

The testing activities described in this document are restricted to drilling, testing, and completing wells during the Pre-Injection phase. Testing and monitoring activities during the Injection and Post-Injection Site Care phases are described in the Testing and Monitoring Plan, along with other non-well related pre-injection baseline activities, such as geochemical monitoring.

The pre-injection operational testing plan described in this document is designed to meet the testing requirements of Title 40 of the U.S. Code of Federal Regulations Section §146.87 (40 CFR §146.87) and the well construction requirements of 40 CFR §146.86.

The pre-operational testing program will utilize a combination of open and cased hole logging, coring, fluid sampling, and formation hydrogeologic testing to determine and verify the depth, thickness, mineralogy, lithology, porosity, permeability, and geomechanical information of the Injection Zone, confining zones, and other relevant geological formations.

All pre-injection testing procedures for logging, sampling, and testing, as required by 40 CFR §146.87, will be submitted to the Underground Injection Control Director for review. The results of the testing activities will be documented in a report and submitted to the US Environmental Protection Agency (EPA) after the well drilling and testing activities have been completed, but before the start of CO₂ injection operations.

The BRP Project will notify the EPA at least 30 days prior to conducting the test and provide a detailed description of the testing procedure. Notice and the opportunity to witness these tests/logs shall be provided to the EPA at least 48 hours in advance of a given test/log.

Plan revision number: 3

Plan revision date: 07/30/2024

A table of the wells described in this document is shown below (Table 1). A summary of pre-operational data collected or planned for collection is presented in Table 2.

Table 1--Summary of wells drilled/planned for the BRP Project

Regulatory Well Name	Project Well Name	Drill Date	Purpose	Latitude (NAD 27)	Longitude (NAD 27)
Shoe Bar 1	SLR1	2023	Stratigraphic test well; to be converted to SLR1	31.76343602	-102.7034981
Shoe Bar 1AZ	ACZ1	2023	Stratigraphic test well	31.76448869	-102.7305326
Shoe Bar 1USDW	USDW1	2023	Monitor lowermost USDW	31.76411900	-102.7316750
Shoe Bar 2SLR	SLR2	2025*	Monitor Injection Zone	31.74670102	-102.7259011
Shoe Bar 3SLR	SLR3	2030*	Monitor Injection Zone	31.78023685	-102.7418093
Shoe Bar 1CCS	BRP CCS1	2024*	CO ₂ Injector	31.76479314	-102.7289311
Shoe Bar 2CCS	BRP CCS2	2024*	CO ₂ Injector	31.76993805	-102.7332448
Shoe Bar 3CCS	BRP CCS3	2024*	CO ₂ Injector	31.76031163	-102.7101566
Shoe Bar 1WW	WW1	2024	Brine water withdrawal	31.76289539	-102.6959232
Shoe Bar 2WW	WW2	2024	Brine water withdrawal	31.78419981	-102.7275869
Shoe Bar 3WW	WW3	2024	Brine water withdrawal	31.75008553	-102.7102206
Shoe Bar 4WW	WW4	2024	Brine water withdrawal	31.76384464	-102.7539505

*Anticipated drill timing

Table 2--Summary of data acquired or planned for wells in the BRP Project

	Basic Log Suite	Advanced Logging Suite				Core Acquisition		Formation Testing					Formation Fluid Sampling	Mechanical Integrity Testing	Plume Monitoring
	GR, SP, NPHI, RHOB, SGR, RES, PEF	ECS	NMR	FMI	Dipole Sonic	Whole Core	Sidewall Core	MDT - Pressure	Mini-Frac	SRT	PFOT	MDT	Downhole Fluid Sampling	Isoscanner/USIT /CBL-VDL	Pulsed Neutron Logging
Shoe Bar 1 (SLR1)	1	1	1	1	1	1	1	1	1	1	1	1	2, 3	1, 2	1, 2, 3
Shoe Bar 1AZ (ACZ1)	1	1	1	1	1	1	1	1		1	1	1	2, 3	1, 2	1, 2, 3
BRP CCS1	1	1	1	1	1			1	1		2	1		1	
BRP CCS2	1	1	1	1	1			1	1		2	1		1	
BRP CCS3	1	1	1	1	1		1	1	1		2	1		1	
USDW1	1												2, 3	1, 2	1, 2, 3
SLR2	1				1			1				1	2, 3	1, 2	1, 2, 3
SLR3	1				1			1				1	2, 3	1, 2	1, 2, 3
WW1	1				1			1				1	2, 3	1, 2	1, 2, 3
WW2	1				1			1				1	2, 3	1, 2	1, 2, 3
WW3	1				1			1				1	2, 3	1, 2	1, 2, 3
WW4	1				1			1				1	2, 3	1, 2	1, 2, 3

Notes: Summary of logging, coring, MIT, formation testing and sampling in the wells at BRP Project. The numbers indicate the phase of the Project the data will be acquired: 1 – During Construction, 2 – During Injection, 3 – During Post-Injection

1.1 Overview of Logging Suite(s)

A brief description of the logging tools that will be run during construction summarized in Table 2 is documented below.

- **Basic log suite:** A triple combo with spectral gamma ray will be the basic log suite that will be run in all the wells in the BRP Project. The measurements obtained include Gamma Ray (Total and Spectral), Spontaneous Potential (SP), Neutron Porosity (NPHI), Bulk Density (RHOB), Resistivity (RES), and Photoelectric Factor (PEF). The combination of these log measurements enables interpretation and quantification of key petrophysical properties such as porosity, mineralogy, fluid saturations with a high degree of resolution and accuracy.

- **Advanced log suite(s)**
 - **Elemental Capture Spectroscopy (ECS):** This tool is used to quantify elemental dry weight concentrations of key elements such as Calcium, Magnesium, Silicon, Sulfur, Iron, and others. This data can then be used to determine detailed mineralogy. The Lithoscanner tool (from Schlumberger) is an example of such a tool.

 - **Nuclear Magnetic Resonance (NMR):** NMR tools can quantify porosity, pore size distribution, bound and free fluid volumes and provide estimation of permeability, from which injectivity can be interpreted.

 - **Formation Micro-Imager (FMI):** This tool when run can generate precisely oriented false-color image of the formation at a 5mm resolution based on an array of micro-resistivity sensors. From these images geoscientists can identify bedding, sedimentary structures, diagenetic features, and tectonic features such as fractures, faults, folds, as well as mechanically induced features from drilling processes like breakouts and/or induced fractures. The orientation (e.g., dip and strike) of any feature observed in the image can also be precisely quantified.

 - **Modular Formation Dynamics Tester (MDT):** A mission-configurable, modular platform consisting of a series of reservoir interfaces (single-packer, dual-packer, or probe types), a downhole pump, a suite of real-time measurements to identify and quantify properties of fluid in the tool flowline, and various sizes and types of fluid sampling chambers. The principal sequestration project applications are to measure formation water mobility, to capture representative formation water

samples (in both USDWs and Injection Zones), and to perform direct in-situ measurements of fracture breakdown pressure and closure pressure (in both Confining Zones and Injection Zones) by pumping fluid into a ~3ft interval isolated by inflatable dual packers.

- Dipole Sonic: These tools quantify the slowness of various acoustic wave modes in the formation, including compressional, fast, and slow shear, horizontal shear, and Stoneley. These measurements provide the starting point for a continuous 1D mechanical earth model (MEM) including interpreted formation properties such as Young's Modulus, Poisson's Ratio, Unconfined Compressive Strength (UCS), and tensile strength. The data can also be used to interpret principal stress magnitudes and orientation. The Sonic Scanner tool (from Schlumberger) is an example of such a tool.
- Sidewall Coring Tool: These tools such as XLRock (from Schlumberger) use a hydraulic-powered rotary drilling assembly that cuts and retrieves a core sample from the borehole wall measuring 1.5" in diameter and up to 3" in length. The samples are suitable for all types of routine core analysis (RCA) as well as a broad portfolio of special core analysis (SCAL) measurements appropriate for CCS projects in both Confining Zones and Injection Zones.

2. Stratigraphic Wells

2.1 Overview of Stratigraphic Wells

The Shoe Bar 1 and Shoe Bar 1AZ stratigraphic wells were drilled in 2023 to provide site-specific characterization data for the BRP site. The Shoe Bar 1AZ is located within the proposed AoR, close to the locations in proposed Injector wells. Core data collected in the Shoe Bar 1AZ is representative of the subsurface at the locations of proposed future injectors BRP CCS1 and BRP CCS2, which will be located less than 2,000 ft around Shoe Bar 1AZ (see additional details in Pre-Operational Plan Appendix A). The Shoe Bar 1 is located in the easternmost extent of the modeled AoR, approximately 1.5 miles East of Shoe Bar 1AZ.

The Project acquired a comprehensive suite of basic and advanced geophysical logs, whole core through the injection interval, sidewall cores, reservoir pressure data and fluid samples. After each well was constructed, the BRP team conducted step-rate tests in the injection and confining intervals. Shoe Bar 1 will be converted to the SLR1; it will be plugged above the Injection Zone and used for future DTS/DAS monitoring. The Shoe Bar 1AZ will be plugged above the Injection Zone prior to the commencement of injection. The portion of the well above the upper confining zone will temporarily be left unplugged and inactive pending further evaluation of utilization for this wellbore.

The following sections summarize the details of the logging and coring plans executed in the stratigraphic wells.

2.2 Logging Program in Stratigraphic Wells

The Shoe Bar 1 was drilled in January 2023. The well was planned with a 3-string casing design with the surface section (or surface string casing) at 0-1,800' MD, intermediate section (or intermediate string casing) at 1,800-3,800' MD, and production section (or long string casing) at 3,800-6,550' MD.

Table 3 summarizes the data acquisition program conducted in the Shoe Bar 1.

Table 3--Data acquired in the Shoe Bar 1 Well

Method	Interval Section(s)	Purpose
Open Hole Logs, Surveys and Sampling During Construction		
Deviation survey [40 CFR §146.87 (a) (1)]	Every 100 ft while drilling as minimum, from surface to TD.	Define well trajectory, displacement, and tortuosity
Wireline- Spontaneous Potential – [40 CFR §146.87 (a) (2) (i)]	Intermediate, Production	Correlation log, volume of shale indicator, estimate salinity
Wireline – Caliper – [40 CFR §146.87 (a) (2) (i)]	Intermediate, Production	Identify borehole enlargement and calculate cement volume
Wireline –Resistivity – [40 CFR §146.87 (a) (3) (i)]	Intermediate, Production	Fluid identification, estimate salinity, correlation log
Wireline -Gamma ray – [40 CFR §146.87 (a) (3) (i)]	Intermediate, Production	Define stratigraphy, correlation log, shale indicator
Wireline -Magnetic resonance image – [40 CFR §146.87 (a) (3) (i)]	Production	Estimate porosity, pore size distribution, permeability index
Wireline -Sonic Scanner – [40 CFR §146.87 (a) (3) (i)]	Intermediate, Production	Estimate mechanical properties, validation of velocity model, well tie to seismic
Wireline - Spectral gamma ray – [40 CFR 146.87 (a) (3) (i)]	Intermediate, Production	Define uranium rich formation, clay indicator
Wireline - Density / neutron – [40 CFR 146.87 (a) (3) (i)]	Intermediate, Production	Estimate porosity, mineralogical characterization
Wireline -High-definition image – [40 CFR §146.87 (a) (3) (i)]	Production	Identify fracture, structural information, minimum stress orientation
Wireline - Litho-scanner – [40 CFR §146.87 (a) (3) (i)]	Production	Identify mineralogy
Wireline - Formation Dynamics Testing	Production	Measure formation pressures, fluid sampling, mini-frac testing
Mud Logging	Surface to TD (every 30 ft)	Identify lithology, hydrocarbon shows, gases composition

The Shoe Bar 1AZ was drilled in August 2023. This well is located in the AoR, within 2,000' of the planned future injector locations. The well was drilled with a 3-string casing design with the surface section at 0-1,800' MD, intermediate section at 1,800-3,910' MD, and production section at 3,910-6,725' MD. The Shoe Bar 1AZ will be plugged above the Injection Zone prior to the commencement of injection. The portion of the well above the upper confining zone will temporarily be left unplugged and inactive pending further evaluation of utilization for this wellbore. Summarized below is the data acquisition program conducted in the Shoe Bar 1AZ.

Table 4--Data acquired in the Shoe Bar 1AZ well

Method	Interval Section(s)	Purpose
Open Hole Logs, Surveys and Sampling During Construction		
Deviation survey [40 CFR §146.87 (a) (1)]	Every 100 ft while drilling as minimum, from surface to TD	Define well trajectory, displacement, and tortuosity
Wireline- Spontaneous Potential – [40 CFR §146.87 (a) (2) (i)], [40 CFR §146.87 (a) (3) (i)]	Surface, Intermediate, Production	Correlation log, volume of shale indicator, estimate salinity
Wireline –Resistivity – [40 CFR §146.87 (a) (2) (i)], [40 CFR §146.87 (a) (3) (i)]	Surface, Intermediate, Production	Fluid identification, estimate salinity, correlation log
Wireline – Caliper – [40 CFR §146.87 (a) (2) (i)], [40 CFR §146.87 (a) (3) (i)]	Surface, Intermediate, Production	Identify borehole enlargement and calculate cement volume
Wireline -Gamma ray – [40 CFR §146.87 (a) (2) (i)], [40 CFR §146.87 (a) (3) (i)]	Surface, Intermediate, Production	Define stratigraphy, correlation log, shale indicator
Wireline -Magnetic resonance image – [40 CFR §146.87 (a) (3) (i)]	Production	Estimate porosity, pore size distribution, permeability index
Wireline -Sonic Scanner – [40 CFR §146.87 (a) (2) (i)], [40 CFR §146.87 (a) (3) (i)]	Surface, Intermediate, Production	Estimate mechanical properties, validation of velocity model, well tie to seismic
Wireline - Spectral gamma ray – [40 CFR §146.87 (a) (2) (i)], [40 CFR §146.87 (a) (3) (i)]	Surface, Intermediate, Production	Define uranium rich formation, clay indicator
Wireline - Density / neutron – [40 CFR §146.87 (a) (2) (i)], [40 CFR §146.87 (a) (3) (i)]	Surface, Intermediate, Production	Estimate porosity, mineralogical characterization
Wireline -High-definition image – [40 CFR §146.87 (a) (3) (i)]	Production	Identify fracture, structural information, minimum stress orientation
Wireline - Litho-scanner – [40 CFR §146.87 (a) (3) (i)]	Production	Identify mineralogy
Wireline - Formation Dynamics Testing	Production	Measure formation pressures, fluid sampling
Mud Logging	Surface to TD (every 30 ft)	Identify lithology, hydrocarbon shows, gases composition

In addition to the open-hole logs, cased-hole logs were acquired over each section post-casing in both stratigraphic wells. The table below summarizes the cased-hole data that was acquired.

Table 5--Cased-hole logs acquired

Method	Interval Section(s)	Purpose
Cased Hole Logs and surveys Before Injection		
Wireline - CBL-VDL-USIT-CCL – [40 CFR §146.87 (a)(2) (ii)], [40 CFR §146.87 (a)(3) (ii)]	Surface, Intermediate, Production	Cement bond, casing integrity. Validate external mechanical integrity
Annulus Pressure Test - Long string casing [40 CFR §146.87 (a)(4) (i)]	Annular between tubing and long string	Validate internal mechanical integrity between the tubing, long-string, and packer
Wireline - Activate pulsed neutron – Long string casing [40 CFR §146.87 (a)(4) (ii)]	Surface, Intermediate, Production	CO ₂ saturation, baseline for monitoring

2.3 Coring Program

2.3.1 Whole and Sidewall Core Acquisition

The coring program for the Shoe Bar 1 and Shoe Bar 1AZ wells was designed to obtain full 4-in whole core from the Sequestration Zone, the Lower San Andres formation. The program collected 1.5-in diameter sidewall core plugs in the Grayburg and Upper San Andres formations, which are the Upper Confining Zones, and the Glorieta and Wichita-Albany formations, which are Lower Confining Zones. In addition, sidewall cores were also obtained to evaluate a prospective secondary sequestration zone, the Clearfork formation.

In Shoe Bar 1, the Project successfully achieved 100% recovery of ~714ft of whole core through the Lower San Andres and 78 sidewall cores from Grayburg, Upper San Andres, Glorieta, Clearfork, and Wichita-Albany formations.

In Shoe Bar 1AZ, the Project successfully achieved 100% recovery of ~725ft of whole core through the Lower San Andres and 51 sidewall cores from Grayburg, Upper San Andres, Glorieta, and Clearfork formations.

2.3.2 Core Analysis Program

The laboratory analysis of core acquired in Shoe Bar 1 and Shoe Bar 1AZ involved core slabbing, routine core analysis (RCA), petrographic analysis, and special core analysis (SCAL). Table 6 summarizes the program.

Table 6--Core Analysis Performed

Core	Test	Frequency
Whole Core	Slabbing	100% of whole core
	DECT Scan	
	WL, UV Photography	
	Core description*	
Full Diameter Core	Total Porosity	12 from Shoe Bar 1; 7 from Shoe Bar 1AZ; in the Injection Zone
	Horizontal permeability	
	Vertical permeability	
	Grain density	
Whole Core, Horizontal plugs	Total Porosity	Selected samples from Upper Confining and Injection Zones
	Permeability	
	Grain density	
	XRF, XRD **	
	Thin section ***	
	SEM	
	MICP	
	Relative permeability	
Whole Core, Vertical plugs	Porosity	Selected samples from Upper Confining and Injection Zones
	Vertical permeability	
	Grain density	
	Entry pressure	
Whole Core, Geomechanical	Static/Dynamic Elastic Anisotropy	Selected samples from Upper Confining and Injection Zones
	Poro-elastic Coefficients (VTI)	
	Multistage Confined Compression	
RSWC XL	Total Porosity	Every sample from Upper Confining and Injection Zones
	Permeability	
	Grain density	

*Core description: Detailed description of the slabbed core will assign core facies based on lithology, texture, biogenic structures, fossils, grain size trends, environment of deposition, and sedimentary structures.

**XRD: This will provide bulk composition and clay typing

***Thin section: A detailed description will include grain composition, pore distribution, textural characteristics, and fabric of the rock.

2.4 Formation Fluid Characterization Program

2.4.1 Acquisition of Formation Fluid Samples

A Modular Formation Dynamics Tester (MDT) tool was utilized during the open-hole wireline logging runs to obtain representative samples of in-situ reservoir fluid. A MDT tool with pump-out module, Live Fluid Analyzer (LFA) module, and flow line resistivity measurement identifies and collects high-quality reservoir fluid samples suitable for laboratory analysis. Flowline

resistivity measurements taken by the sensor on the MDT tool help discriminate between formation fluids and filtrate from muds. Equipping the MDT tool with a pump-out module makes it possible to sample fluid, while monitoring the flowline resistivity, by pumping filtrate-contaminated fluid into the mud column. Fluid removed from the formation is excluded from the sample chamber until an uncontaminated sample can be recovered.

The BRP Project utilized an MDT tool to acquire baseline reservoir fluid samples from three depths in the Lower San Andres in each of the two stratigraphic wells. These samples were transported under pressure to a third-party lab for comprehensive analysis including pH, conductivity, alkalinity, major cations, major anions, trace metals, dissolved gases, density, and TDS (Total Dissolved Solids) among others.

2.4.2 Analysis and Reporting

Table 7 indicates the analytical methods used to determine the measured parameters.

Table 7--Parameters and analytical methods for fluid analyses for Shoe Bar 1 and Shoe Bar 1AZ

Parameter	Analytical method
Lower San Andres (Injection Interval)	
Cations: Al, Ba, Cd, Ca, Cr, Co, Cu, Fe (dissolved), Fe (total), Pb, Li, Mg, Mn, Mo, Ni, P, K, Si, Na, Sr, V, Zn	CL Metals by ICP – Section 1.28-2
Cations: Hg (Mercury)	SW7470A
Anions: B (as B(OH) ₄ ⁻)	CL Metals by ICP – Section 1.28-2
Anions: F, NO ₃ , NO ₂ , PO ₄ , SO ₄	CL Anions by IC – Section 1.27-2
Dissolved CO ₂	ASTM D 513-82
Anions: Br, Cl, I	CL Anions by IC – Section 1.27-2/ CL Chlorides Determination – Section 1.22-3
Anions: Ar (arsenic)	EPA 200.7
Anions: S (sulfide)	Standard Methods: 4500-S2-D
Total organic carbon	SM5310B
Total dissolved solids (TDS)	EPA 160.1
Total Sulfate and Sulfide	Standard Methods: 4500-S2-D
Density	ASTM D1217
Dissolved CO ₂	ASTM D 513-82
Alkalinity (as HCO ₃ ⁻), Carbonate (CO ₃ ²⁻)	Titration, ASTM D3875-97 CL Bicarbonate/Carbonate Determination Section 1.26-3
pH and Temperature	ASTM D1293 (pH Electrode)
Conductivity	ASTM D1125
Specific gravity	ASTM D1429 / ASTM D1480
δ ¹³ C	gas-bench IRMS
δ ¹⁸ O	gas-bench IRMS
δD	gas-bench IRMS

Plan revision number: 3

Plan revision date: 07/30/2024

Dissolved Gas Abundances: CO ₂ , CO, N ₂ , Ar, He, H ₂ , O ₂ , C1-C6+	Determined by GC for full compositions
Dissolved Gas Isotopes: δ ¹³ CO ₂ , δ ¹⁸ CO ₂	Conventional Offline Prep / Dual Inlet MS
⁸⁷ Sr/ ⁸⁶ Sr	Strontium isolation by extraction chromatography, analysis by MC-ICP-MS

2.5 Fracture Pressure

2.5.1 Confining zone

The fracture pressures of the Upper Confining Zone (Upper San Andres and Glorieta) and the Injection Zone (Lower San Andres) were estimated using mini-frac tests in the Shoe Bar 1 and Shoe Bar 1AZ wells. The fracture gradients are in the range of 1.19-1.58psi/ft. The table below shows the results.

Table 8--Summary of Confining Zone Fracture Pressure Estimates

Well	Test	Zone	Formation	Measured Depth, ft	Fracture propagation pressure, psi	Fracture gradient, psi/ft
Shoe Bar 1	Mini-frac	Upper confining zone	Upper San Andres	4042	5941	1.47
Shoe Bar 1	Mini-frac	Lower confining zone	Glorieta	5076	7044	1.39
Shoe Bar 1AZ	Mini-frac	Upper confining zone	Upper San Andres	3792	Could not initiate fracture at max. downhole pressure of 6000 psi	>1.58
Shoe Bar 1AZ	Mini-frac	Lower Confining Zone	Glorieta	5026	Could not initiate fracture at max. downhole pressure of 6000 psi	>1.19

2.5.2 Injection Zone

The fracture pressure of the Injection Zone was estimated using Mini-frac (or Diagnostic Fracture Injection Test) and Step Rate Tests (SRT) performed in the Shoe Bar 1 and Shoe Bar 1AZ wells. The table below summarizes the results:

Table 9–Summary of Injection Zone Fracture Pressure Estimates

Well	Zone	Tested Interval Top Perf-Bottom Perf (MD, ft)	Initial Reservoir Pressure (psi)	Type of Test	Estimated Fracture Gradient (psi-ft)
Shoe Bar 1	Lower San Andres	4827-4829	2200@4400ft	Mini-Frac	■
Shoe Bar 1	Lower San Andres	4421-5024	2200@4400ft	Step Rate Test	■
Shoe Bar 1AZ	Lower San Andres	5122-5132	2522@5088ft	Step Rate Test	■
Shoe Bar 1AZ	Upper San Andres	4723-4733	2307@4596ft	Step Rate Test	■

3. Injection Wells – Pre-Op Strategy

The BRP Project will construct three new wells for CO₂ injection. An extensive suite of tests and logs will be acquired during drilling, casing installation, and post-casing installation in the injector wells in accordance with the testing required under 40 CFR §146.87(a), (b), (c), and (d).

3.1 Logging Program

The Project will plan and execute an extensive data acquisition program consisting of logs, surveys, and tests consistent with the data acquired in the stratigraphic test wells, shown in Table 4.

The table below shows the proposed logging and survey planned for injector wells.

Table 10–Proposed logging program for CO₂ injectors

Method	Interval Section(s)	Purpose
Open Hole Logs, Surveys and Sampling During Construction		
Deviation survey	Every 100 ft while drilling as minimum, from surface to TD	Define well trajectory, displacement, and tortuosity
Wireline – Spontaneous Potential	Surface, Intermediate, Production	Correlation log, volume of shale indicator, estimate salinity
Wireline – Resistivity	Surface, Intermediate, Production	Fluid identification, estimate salinity, correlation log
Wireline – Caliper	Surface, Intermediate, Production	Identify borehole enlargement and calculate cement volume
Wireline – Gamma ray	Intermediate, Production	Define stratigraphy, correlation log, shale indicator

Wireline – Magnetic resonance image	Production	Estimate porosity, pore size distribution, permeability index
Wireline – Sonic Scanner	Intermediate, Production	Estimate mechanical properties, validation of velocity model, well tie to seismic
Wireline – Spectral gamma ray	Intermediate, Production	Define uranium rich formation, clay indicator
Wireline – Density / neutron	Intermediate, Production	Estimate porosity, mineralogical characterization
Wireline – High-definition image	Production	Identify fracture, structural information, minimum stress orientation
Wireline – Litho-scanner or equivalent	Production	Identify mineralogy
Wireline – Formation Dynamics Testing	Production	Measure formation pressures, fluid sampling, mini-frac testing
Mud Logging	Surface to TD (every 30 ft)	Identify lithology, hydrocarbon shows, gases composition
Cased Hole Logs and surveys Before Injection		
Wireline – CBL-VDL-USIT (Casing inspection log)-CCL	Surface, Intermediate, Production	Cement bond, casing inspection log (USIT); Validate external mechanical integrity
Annulus Pressure Test – Long string casing	Annular between tubing and long string	Validate internal mechanical integrity between the tubing, long-string, and packer
Wireline – Activate pulsed neutron (Oxygen Activation Log) – Long string casing	Surface, Intermediate, Production	CO ₂ saturation, baseline for monitoring
Wireline – Temperature Log	Surface, Intermediate, Production	Measure baseline temperature profile on the well from surface to top of perforation
Fiber Optic – DAS, DTS survey	Surface, Intermediate, Production	Measure baseline temperature profile on the well from surface to top of perforation Acquire baseline 3D VSP survey for monitoring plume migration over time

3.2 Coring Program

The Project will not collect whole core or sidewall cores in the CO₂ injector wells BRP CCS1 and BRP CCS2 wells, because representative core data were already acquired in the Shoe Bar 1AZ, which is located less than 2,000' away from the planned injector wells. Based on seismic interpretation of a recently acquired project-specific 3D dataset, OLCV interprets structural and stratigraphic conformance, and consistency of rock and fluid properties between the stratigraphic test well and the planned injectors. See Appendix A to the BRP Pre-Operations Testing Plan for

additional justification on the similarity of geology at the stratigraphic test well location compared to the planned injectors.

The Project will collect up to 75 sidewall cores in the BRP CCS3 well, which is anticipated to have different rock properties than were encountered in the nearby Shoe Bar 1. The core depths will be finalized based on the petrophysical analysis of the triple combo logs run prior to the sidewall coring run. The Project will plan to acquire ~10 (subject to change) sidewall cores in each Confining Zone and ~50 (subject to change) sidewall cores in the Injection Zone.

Table 11–Projected depths for rotary sidewall core sampling zones in well BRP CCS3

Well Name	Formation Top	Comment	Z [FT]	MD [FT]
CCS3	Grayburg	Upper Confining Zone	-844	4002
CCS3	Upper San Andres	Upper Confining Zone	-1052	4282
CCS3	Lower San Andres (G4)	Injection Zone	-1410	4959
CCS3	Lower San Andres (G1)	Injection Zone	-1543	5225
CCS3	Lower San Andres (Holt)	Injection Zone	-1934	6006
CCS3	Glorieta	Lower Confining Zone	-2089	6316

Table 12–Core analysis plan for BRP CCS3

Core	Test	Frequency
Rotary Sidewall Cores (RSWC)	Total Porosity (Ambient and NCS) Permeability (Ambient and NCS) Grain density	Every sample
	XRD ** Thin section *** SEM MICP	Select samples from Confining Zones and Injection Zone

*XRD: This will provide bulk composition and clay typing

**Thin section: A detailed description will include grain composition, pore distribution, textural characteristics, and fabric of the rock.

Geomechanical testing of core is required to accomplish at least two primary goals. First is to calibrate the dynamic and static elastic properties that are inputs to the well-based stress model. The second objective is to build a rock mechanics database that is used to build predictive rock property models so that rock properties can be predicted in future wells with the necessary input well data. The testing results also provide the foundational data required to understand physical properties and characteristics of facies, lithotypes, textures, etc. Both dynamic and static data are required to build dynamic to static conversions. Dynamic data are calculated from velocity data and density and are equivalent to the same properties calculated from well data. Dynamic data must be converted to static data and the dynamic to static conversions based on core data are required to accomplish critical step. Table 11 summarizes the dynamic and static measurements to

be completed on the core samples. Testing is accomplished using the proprietary single plug protocol from New England Research (NER). The method requires only a single horizontal plug and provide vertical and horizontal measurements required to characterize elastic anisotropy. Because it only requires a single horizontal plug, rotary sidewall cores (RSWC) plugs can be utilized to expand the scope of investigation of both seal and reservoir formations. In Shoe Bar 1, 12 samples from the suite of RSWC plugs are tested in the reservoir, upper seal, and lower seal. In Shoe Bar 1AZ, both whole core and RSWC are utilized to characterize 20 samples distributed across the upper seal, reservoir, and lower seal.

Table 13–Geomechanical Parameters from Core Testing

Property	Variable	Dynamic	Static
Density	Rhob	--	Yes
Compressional Velocity	Vp	Yes	--
Shear Velocity	Vs	Yes	--
Young's Modulus	E	Yes	Yes
Poisson's Ratio	v	Yes	Yes
Biot's Coefficient	α	--	Yes
Stiffness Coefficients	Cij	Yes	Yes
Compliance Coefficients	Sij	Yes	Yes
Unconfined Compressive Strength	UCS	--	Yes

3.3 Well Mechanical Integrity Testing (MIT)

The BRP Project will conduct both internal and external mechanical integrity tests on all injection wells in the Project. Internal mechanical integrity refers to the absence of leaks in the casing by tubing annulus, the tubing, and the packer. External mechanical integrity refers to the absence of formation fluid or CO₂ movement through channels in the cement on the exterior of the casing.

Upon completion and installation of the downhole equipment in the wells, BRP will conduct an annular pressure test (APT) to verify internal mechanical integrity. The APT is a short-term pressure test (30 minutes) where the well is shut in and the fluid in the annulus is pressurized to a predetermined pressure and is monitored for leak off. BRP will use a test pressure of 500 psi for the MIT's. BRP will use a 5% decrease in pressure (test pressure x .05) from the stabilized test pressure during the duration of the test to determine if test is successful. If the annulus pressure decreases by $\geq 5\%$, the well will have failed the APT. If a well fails an APT, the test will be repeated. If the APT is again failed, the downhole equipment will be removed from the well and the source of the failure will be investigated. In general, the test procedure will be as follows:

1. Connect a high-resolution pressure transducer to the annulus casing valve and increase the annulus pressure to 500 psi and hold this pressure for 30 minutes.
2. At the conclusion of the 30-minute test the annulus pressure will be bled off to 0 psi and the pressure recording equipment will be removed from the casing valve.

Upon well completion, BRP will run cased hole logs to demonstrate external mechanical integrity of the casing and cement sheath prior to the start-up of operations. BRP will run Casing Inspection Logs (CIL) to evaluate casing integrity. In addition, BRP will acquire baseline temperature logs to demonstrate a lack of fluid movement through channels or communication paths through the tubing or annulus. BRP will also run an ultrasonic imaging tool (USIT) to provide further confidence that there are no channels in the cement sheath for formation fluids or CO₂ to migrate upwards in the well.

3.4 Cement Logs

The BRP Project will collect noninvasive data to confirm the presence of an annular barrier and bond between casing and cement. Cement placement is a critical component of the well architecture for ensuring mechanical support of the casing, protection from fluid corrosion, and for isolation of permeable zones at different pressure regimes to prevent hydraulic communication. Tools such as Ultrasonic Imager tool (USIT) uses a single transducer mounted on an Ultrasonic Rotating Sub (USRS) on the bottom of the tool. The transmitter emits ultrasonic pulses between 200 and 700 kHz and measures the received ultrasonic waveforms reflected from the internal and external casing interfaces. The rate of decay of the waveforms received indicates the quality of the cement bond at the cement/casing interface, and the resonant frequency of the casing provides the casing wall thickness required for pipe inspection. Because the transducer is mounted on the rotating sub, the entire circumference of the casing is scanned. This 360° data coverage enables the evaluation of the quality of the cement bond as well as the determination of the internal and external casing condition. The very high angular and vertical resolutions can detect channels as narrow as 1.2 in. [3.05 cm]. Cement bond, thickness, internal and external radii, and self-explanatory maps are generated in real time at the wellsite.

An advanced option such as Isolation Scanner can be used to provide more certainty. This tool combines a pulse-echo technique along with an ultrasonic technique to induce a flexural wave in the casing. A transmitter measures the resulting signals at two receivers, and the attenuation calculated between the two receivers is paired with the pulse-echo measurement and compared with a laboratory-measured database to produce an image of the material immediately behind the casing. By measuring radially beyond traditional cement evaluation boundaries, this service confirms zonal isolation, pinpoints any channels in the cement, and ensures confident operational decisions. The signal resulting from the interface between the annulus and the borehole or outer casing can be detected and measured. These third-interface echoes (TIEs) provide the position of the casing within the borehole, and if the borehole size is known, the velocity of the annulus material can be determined. These flexural measurements can provide useful information to image complex cement geometries and are helpful datasets if remediation is required.

3.5 Fracture Pressure

The fracture pressure of the Confining and Injection Zones is determined to understand injection pressure limit to maintain matrix flow. To determine the fracture pressure, a fracture is created and sustained for a small amount of time. The fracture pressure in the Injection Zone is determined through a mini-frac or Diagnostic Fracture Injection Test (DFIT). These tests will determine Instantaneous Shut-in Pressure (ISIP), the ISIP Gradient, and the Fracture Closure Pressure (FCP). These terms are defined as below and illustrated in Figure 1.

- Instantaneous Shut-In Pressure (ISIP) = Final Injection Pressure – friction pressure
- ISIP Gradient (or fracture gradient) = ISIP/formation depth
- Fracture Extension Pressure (FEP) = Minimum pressure need to develop and extend a fracture once it has been initiated
- Fracture Closure Pressure (FCP) = Minimum pressure needed to keep a fracture open; this is also the minimum horizontal formation stress
- Net Pressure (Δp_{net}) = Pressure in the fracture above fracture closure pressure

Following the drilling and logging of the injection well(s), an open hole wireline formation tester (such as MDT) mini-frac will be performed to determine the minimum horizontal stress of the formation intervals. The tester will be setup in a dual packer configuration to isolate ~3ft intervals for stress testing to determine the fracture initiation, fracture breakdown, and fracture propagation pressure. The proposed test intervals will be pre-screened to ensure no structural weaknesses (such as natural fractures) are present using a processed FMI log. The mini-frac operations will preferably occur from the deepest to shallowest depth interval following the procedure outlined below:

Step 1: Packer Inflation

- Inflate the packers until the pressure in the interval (PAQP) starts to rise. When PAQP reaches 100psi greater than hydrostatic pressure, close the inflate seal vale, stop the pump, open the interval seal valve, and exit port to relieve the pressure. This will also allow the packers to relax during the inflation process. Continue to inflate the packers to 300-400 psi inflation pressure.

Step 2: Leak Off Test

- Carry out at least one leak-off test (doing two or three is better). The purpose of the test is to check that the pressure rises roughly linearly with time during injection, which indicates that there is only a small amount of leak-off and that enough flow rate will be available to drive a hydraulic fracture into the formation. Another advantage of this test, when carried

out several times, is that it minimizes the storage of the tool as the packers ease their way on the wellbore wall.

- Inject at a constant rate until pressure is approximately 1000psi below the estimated breakdown pressure.
- Stop injection and record the pressure decline. This test may take less than a minute. In low permeability formations, it is acceptable to not have to wait until pressure comes back to the initial value (it might take unreasonably long to do so).

Step 3: Hydraulic Fracturing Cycle

- To initiate a fracture, pump into the interval at a constant rate of about 1000 rpm (up to 2200 rpm). After a period of pressure build-up, a sudden decrease of injection pressure should be observed. This is the fracture initiation pressure.
- Continue pumping until a stable or gradually increasing fracture propagation trend is observed. Pump for 2-3 more minutes.
- Close the interval valve and immediately stop the pump. Monitor pressure decline until it stabilizes or reaches approximately 500 psi above hydrostatic pressure. In very low permeability intervals, the flowback sample chamber can be used to help with fracture closure.

Step 4: Re-opening Tests

- Reopen the fracture by injecting at the same rate until a fracture propagation trend is observed again. Pump for 2-3 minutes and shut in. Monitor and record the pressure decline.
- 2 or 3 more fracture reopening cycles should then be performed. These reopening tests will confirm the presence of a fracture and are critical to ensure that the minimum principal stress has indeed been measured. More cycles may be added if quality of the data, in particular the repeatability of the pressure at which the fracture propagates, is not satisfactory.

Mini-fracs will be performed in distinct porosity / permeability packages within the proposed Injection Zone and Upper and Lower Confining Zones. Thin intervals (<2ft) that are interpreted to have limited horizontal extent will not be considered. The interval for mini-frac will be selected upon review of logging data ($\Phi > 10\%$, Layer thickness $> 5\text{ft}$). The Fracture Extension Pressure will be interpreted by qualified OLCV reservoir and completions engineers to determine injection limits throughout the Injection Zone.

To perform a DFIT, the test zone will be perforated with a limited number of perforations to ensure fluid is injected over a small area. Fluid will then be injected down the tubing to apply pressure to the formation to induce a breakdown of the formation and establish a fracture. Pressure will be recorded on a surface gauge attached to the wellhead, and at a gauge at the end of the tubing. Once a fracture is created, a small volume of fluid will be pumped to extend the fracture before injection

is terminated. To extend the fracture, the Δp_{net} needs to be above the FCP. The ISIP is the final pressure point when rate and pressure drop is zero, where net pressure is still present, and the fracture is open. At the ISIP, a fracture gradient is calculated at the depth of the fracture. Pressure decline is analyzed using G-function and root-time methods to determine fracture closure pressure.

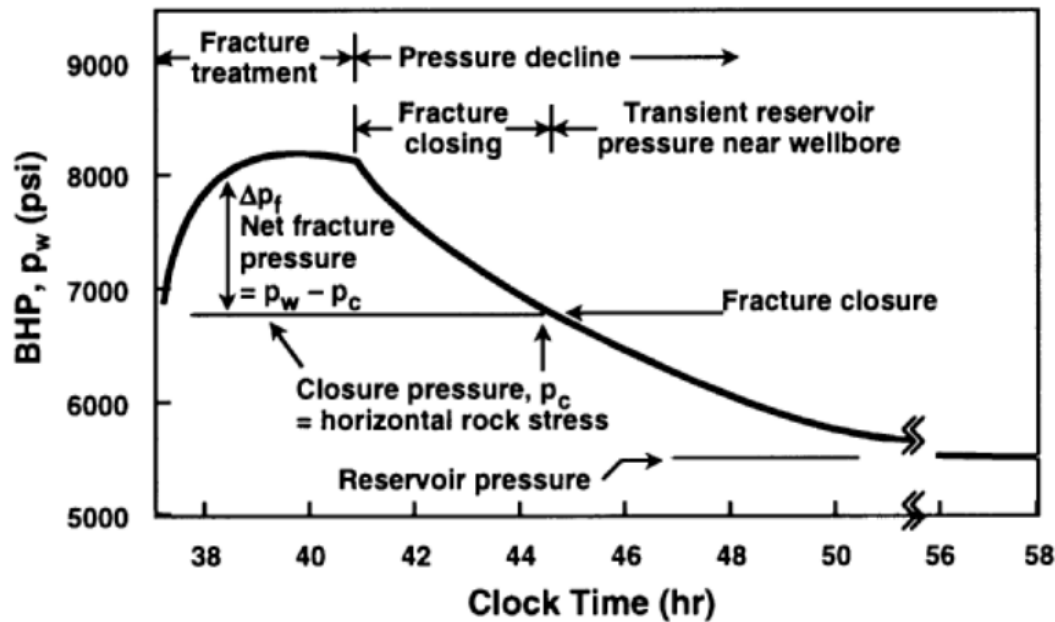

Figure 1: Well Injection Test (Talley, 1999)

3.6 Injection Well Testing

An injection test will be performed in the Lower San Andres after the injection well is complete, including perforation of the Injection Zone and installation of the injection tubing and packer. The pre-operation injectivity testing will serve as the baseline for future pressure fall-off testing. The purpose of conducting an injectivity test is to verify or establish the injection well operating parameters and constrain the inputs used for dynamic injection simulation modeling.

The injection testing will comprise of a period (typically 12-24hrs) of injection at constant rate (typically 0.5-2bpm) subject to a maximum bottom hole pressure limit (less or equal to 90% of the estimated fracture gradient for the perforated interval). This is followed by a shut-in/pressure fall off period (typically 24-48hrs) for monitoring. The injection period will be used to establish/monitor well injectivity performance and the fall off analysis will indicate the well/reservoir flow regime, average reservoir flow characteristics and the presence (if any) of reservoir baffles/boundaries/interwell interference. The tests will be planned to cover the entire

perforated interval of the injector well. Injection profile logs may be run to further verify injection test results.

3.7 Pressure Fall-Off Testing

The main objectives for the pressure fall-off testing are to:

- Inform the expected rate and volume of CO₂ injectivity into the Lower San Andres formation.
- Identify potential baffles or barriers to subsurface flow.
- Verify or establish the maximum operation pressures of the well.
- Establish baseline reservoir performance for comparison with subsequent tests.

3.7.1 Test Activity Summary

The pre-injection test will be performed using brine or municipal water. There will be an injection period at constant rate followed by a zero-rate (shut-in) period for pressure monitoring (Figure 2).

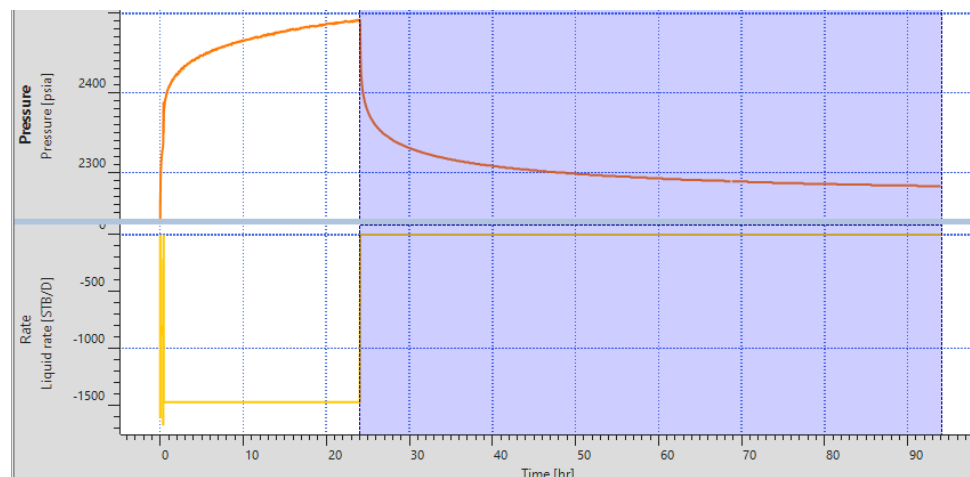

Figure 2: Schematic of Injection Fall-off testing

The test will be conducted with the following considerations:

- The maximum injection pressure will be $\leq 90\%$ of the estimated fracture pressure of the interval. The shut-in period will be sufficient to observe near-wellbore reservoir and boundary effects.
- Bottomhole pressure measurements will be recorded using the downhole pressure gauge near the perforations. A surface pressure gauge may also serve as a monitoring tool for tracking the test progress.
- Injection profile logs and other complementary data may be acquired during the test.

- Testing procedures will follow the EPA recommended methodology (EPA, 2002). The recommendations provided in these guidance documents will be followed to the extent possible. If BRP proposes a significantly different approach, the proposed operational changes will be reviewed with the UIC Program Director prior to initiation.

The following general procedure will be followed for pressure fall off testing:

1. Hook-up brine or municipal water to the well to prepare for injection.
2. Record static shut-in pressure at the downhole gauge.
3. Commence injection per planned rate schedule, approximately 1bpm increase every 30mins until the planned maximum injection rate is reached.
4. Maintain the injection rate within the maximum injection pressure limit for approximately 24 hours.
5. Cease injection as rapidly as possible using a controlled shut-down, and commence pressure fall off testing.
6. Perform a preliminary analysis of the pressure fall off data after 24 hours to identify radial flow period as well as other transient reservoir features.
7. End the pressure fall off test after confirmation of sufficient data acquisition.

Note: The injection rate schedule and the duration of the injection period and the pressure fall-off testing may be modified based on dynamic reservoir response.

3.7.2 Analysis and Reporting

Fall-off testing analysis allows for calculation of the following parameters: transmissivity, storage capability, skin factor, and well flowing and static pressures. A Cartesian plot of the pressure and temperature versus real time or elapsed time will be used to confirm pressure stabilization and look for anomalous data. A log-log diagnostic of the pressure and semilog derivative analysis will be performed for well/reservoir performance characterization (Petrowiki, 2016)

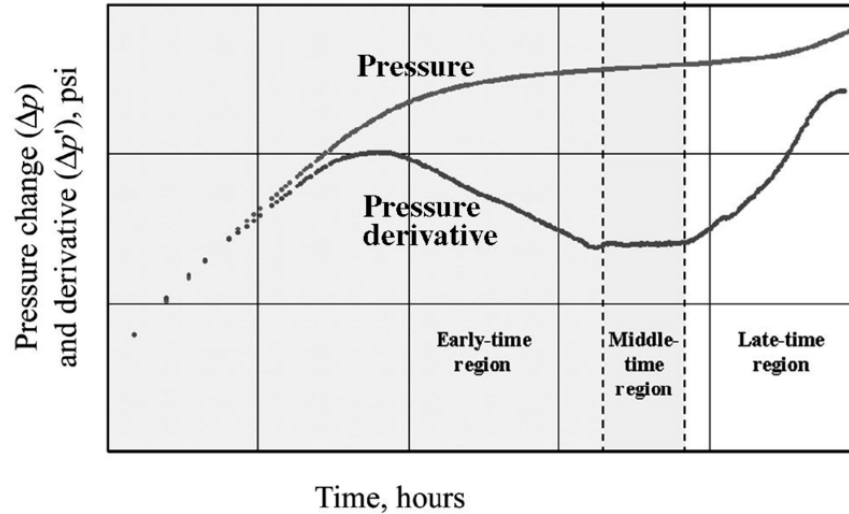

Figure 3. Pressure derivative analysis diagnostic chart (Petrowiki, 2016)

BRP will conduct the following data analysis, integration, and reporting:

- The results of the wireline logging program and the fracture pressure evaluation program will be integrated to support and corroborate the hydrogeologic properties.
- The fall-off testing report will be submitted no later than 60 days following the test and will include well schematic, gauge information, test information, rate/pressure data, reservoir parameters and summary of analysis.
- The testing will be repeated using carbon dioxide within the first 90 days following initiation of sequestration operations. This will allow for comparison to the baseline fluid-to-fluid test with the change in the injection fluid from brine water to carbon dioxide.
- The fall-off test will be performed annually at five-year intervals (within +/-3 months of the anniversary of the previous test), for the lifetime of injection operations. Periodic testing is expected to provide insight into the performance of sequestration site and potentially aid in interpreting the dimensions of the CO₂ plume, based on the expected lateral transition from supercritical CO₂ near the wellbore to native formation brine beyond the plume.
- A final pressure fall-off test will be run after the cessation of injection into the Injection Well.

3.8 Injection Wells Directional Survey

Wellbore deviation measurements will be conducted at periodic intervals while drilling the injection wells. Additionally, a final directional survey may be acquired from total depth to the surface to provide borehole inclination and azimuthal information.

3.9 Injection Wells Formation Pressure and Fluid Sampling

The BRP Project will utilize a formation testing tool (example: MDT) to quantify the reservoir pore pressure and collect fluids from selected intervals in the Injection Zone. The pore pressure testing, and fluid sampling procedure is outlined below:

1. Rig up formation testing tool.
2. Run in hole, for casing check, to above casing shoe.
3. Run in hole for depth correlation. Correlation should be recorded in the same direction as reference log (mostly log up)
4. Log depth correlation pass.
5. Perform pore pressure tests at selected depth intervals in formations of interest.
 - a. Two consecutive pretests of 10cc each at every station is run using volumetric drawdown.
 - b. After setting the tool and performing the first 10cc pretest, pressure should be allowed to stabilize only to a 10th of a psi following which the second 10cc pretest should be carried out and pressure allowed to build up to a 100th of a psi for 20 seconds.
 - c. If after the first 10cc pretest the formation appears to be tight (labeled as dry test), the tool should be retracted without doing a second pretest.
6. Upon completion of pressure testing, re-log for depth correlation.
7. Pick depth intervals with good mobility (identified from pressure tests) for fluid sampling.
8. Perform fluid sampling at selected depth intervals. This involves pump out of fluid volume while monitoring the fluid properties in real time using Live Fluid Analyzer (LFA) module to capture reservoir fluid without mud or other contaminants. The sampling steps involve:
 - a. Inflate the packers with 5-7 liters (between 350-400 psi). Inflation pressure may decrease during operations to as low as 20-50 psi, but no further action is required.
 - b. Perform a pretest with 2-4 strokes to ensure seal. Expected pretest duration is 10-15 minutes.
 - c. Pump-out starting at 300 rpm and increase the rate by 300 rpm steps to the highest rate possible without exceeding tool limitations (5000psi differential pressure on packers). Continue to pump out until formation fluid is observed on the Live Fluid Analyzer (LFA) module. Expected duration of this step is 45 minutes.
 - d. Continue to pump-out at the same rate until low contamination is achieved. The expected duration is 30 minutes.
 - e. Fill sampling bottle with formation fluid and seal.
 - f. If more sampling volume is needed, continue to pump-out and fill additional bottles.
9. Pull out of hole to surface.

Based on data from the Shoe Bar 1 and Shoe Bar 1AZ, OLCV anticipates encountering three distinct porosity zones. OLCV will collect fluid and dissolved gas samples in each of these zones. The final sampling depths will be selected after reviewing logs for the specific Injector well. The analytes and analytical methods for fluids and dissolved gasses are shown in Table 14.

Table 14. Summary of analytical parameters for fluid and dissolved gas samples in the Injection Zone (Lower San Andres).

Laboratory Analyte	Analytical Methods ¹	Detection Limit / Range ²	Typical Precision ²	QC Requirements
Total and Dissolved Metals: Ag, Al, As, Ba, Cd, Co, Cr, Cu, Mn, Mo, Ni, Pb, Sb, Se, Sr, Th, Tl, U, V, and Zn	USEPA Method 200.8	0.00004 to 0.003 mg/L	±20	Daily calibration, Initial QC checks (ICV, ICB, RL) method blank, lab control samples, matrix spikes and sample duplicate, CCV/CCB every 10 samples or part thereof
Total and Dissolved Metals: B, Ca, Fe, K, Mg, Li, Na, Si, Sr, Ti	USEPA Method 200.7	0.003 to 0.254 mg/L	±20	Daily calibration, Initial QC checks (IPC, ICV, ICB, RL) method blank, lab control samples, matrix spike and matrix spike dup; CCV/CCB every 10 samples or part thereof
Total and Dissolved Hg	USEPA Method 245.7	19.6 ng/L	±20	Calibration as needed, daily QC checks; ICV, ICB, RL, method blank, lab control samples, matrix spike and matrix spike dup; CCV/CCB every 10 samples or part thereof
Dissolved Inorganic Carbon (DIC); Dissolved Organic Carbon (DOC)	Standard Method 5310C	0.198 to 0.290 mg/L	±20	Calibration as needed, daily QC checks; ICV, ICB, RL, method blank, lab control samples, matrix spike and matrix spike dup; CCV/CCB every 10 samples or part thereof
Dissolved CO ₂	Standard Method 4500 CO ₂ D	8 mg/L	±20	Frequent calibration, method blank, lab control samples, matrix spikes and sample duplicate.
Alkalinity: Total, Bicarbonate, Carbonate, and Hydroxide	Standard Method 2320B	8 mg/L	±20	method blank, lab control samples, matrix spikes
Major Anions: Br, Cl, F, and SO ₄ , NO ₂ and NO ₃ as N	USEPA Method 300.0	0.003 to 0.563 mg/L	±20	Calibration as needed, daily QC checks; ICV, ICB, RL, method blank, lab control samples, matrix spike and matrix spike dup; CCV/CCB every 10 samples or part thereof

PO ₄ as P	USEPA Method 365.1	0.0215 mg/L	±20	Daily calibration, Initial QC checks (ICV, ICB, RL) method blank, lab control samples, matrix spikes and sample duplicate, CCV/CCB every 10 samples or part thereof
Dissolved H ₂ S (Sulfide)	Standard Method 4500S2-D	0.026 mg/L	±20	Calibration as needed, daily QC checks; ICV, ICB, RL, method blank, lab control samples, matrix spike and matrix spike dup
Total Dissolved Solids (TDS)	USEPA Method 160.1	10 mg/L	±20	Method blank, lab control samples, and sample duplicate
Conductivity	Standard Method 2510B	0 to 200 mS/cm	±1%	Calibration as needed, daily QC checks (1413, 14130 and second source SRM), CCV every 10 samples or part thereof
pH and Temperature	USEPA Method 150.1	0.1 to 14 pH units	±0.1 pH units	Daily calibration, second source SRM, CCV's every 10 samples or part thereof
Specific Gravity	ASTM Method D1429-03	NA	To the nearest thousandths decimal	Duplicates
Cation Anion Balance	Calculation	NA	±10	Calculation
Dissolved Gas Abundances: CO ₂ , CO, N ₂ , Ar, He, H ₂ , O ₂ , C1-C6+	In-house Lab SOP, similar to RSK-175	1 to 100 ppm, varies by component	C1-C4: ± 5%; C5-C6+: ± 10%	20% of all analyses are check/reference standards.
Dissolved Gas Isotopes: δ ¹³ C of C1-C5 and CO ₂ , δ ² H of C1	High precision (offline) analysis via Dual Inlet IRMS	Varies by component	δ ¹³ C: 0.1 per mil; δ ² H: 3.5 per mil	20% of all analyses are check/reference standards.
¹⁴ C of C1	AMS - subcontracted to Beta Analytic	0.44 pMC	± 1 to 2 pMC	Daily monitoring of instrumentation and chemical purity in addition to extensive computer and human cross-checks.
¹⁴ C of DIC	AMS - subcontracted to Beta Analytic	Depends on available sample volume	± 1 to 2 pMC	Daily monitoring of instrumentation and chemical purity in addition to extensive computer and human cross-checks.
δ ¹³ C of DIC	Gas Bench/CF-IRMS	Depends on available sample volume, minimum of	0.20 per mil	20% of all analyses are either check/reference standards or duplicate analyses.

		50mg/L required		
$\delta^{18}\text{O}$ and $\delta^2\text{H}$ of H_2O	Analyzed via CRDS	N/A	$\delta^{18}\text{O}$: 0.10 per mil; $\delta^2\text{H}$: 2.0 per mil	20% of all analyses are either check/reference standards or duplicate analyses.
$^{87}\text{Sr}/^{86}\text{Sr}$	TIMS - subcontracted to the University of AZ	Approximately 40 ppm	± 0.00002	SRM 987 Sr standard within the long-term precision (external precision) of ± 0.00002 accepted value of 0.71025
$^{228}\text{Ra}/^{226}\text{Ra}$	USEPA Method 901.1	50 pCi/L (RL)	$\pm 25\%$	Frequent calibration, method blank, lab control samples, matrix spikes and sample duplicate.
Field Parameters				
pH (Field)	Standard Method 2 4500-H+ B-2000	2 to 12 pH units	± 0.2 pH units	User calibration per manufacturer recommendation
Specific conductance (Field)	EPA Method 120.1	0 to 200 mS/cm	$\pm 1\%$	User calibration per manufacturer recommendation
Temperature (Field)	Standard Method 2550 B-2000	-5 to 50 °C	± 0.2 °C	Factory calibration
Oxidation-Reduction Potential (Field)	Standard Method 2580	-1999 to +1999 mV	± 20 mV	User calibration per manufacturer recommendation
Dissolved Oxygen (Field)	ASTM Method D888-09 (C)	0 to 50 mg/L	0 to 20 mg/L: ± 0.1 mg/L or 1% of reading, whichever is greater; 20 – 50 mg/L: $\pm 8\%$ of reading	User calibration per manufacturer recommendation
Turbidity (Field)	USEPA Method 180.1	0 to 1000 NTU	$\pm 1\%$ of reading or 0.01 NTU, whichever is greater	User calibration per manufacturer recommendation

¹An equivalent method may be employed with the prior approval of the UIC Program Director.

²Detection limits and precision (laboratory control limits) are typical for these analytical methods.

* Analytical parameters to be included during the pre-injection phase, and only as needed during the injection and post-injection phases of the Project.

3.10 Temperature logging

Temperature logs are used to locate gas entries, detect casing leaks, and evaluate fluid movement behind casing. They are also used to detect lost-circulation zones and cement placement. Temperature logs are used as a basic diagnostic tool and are usually paired with other tools like acoustics or multi arms calipers if more in depth analysis is required.

Temperature instruments used today are based on elements with resistances that vary with temperature. The variable resistance element is connected with bridge circuitry or constant current circuit, so that a voltage response proportional to temperature is obtained. The voltage signal from temperature device is then usually converted to a frequency signal transmitted to the surface, where it is converted back to a voltage signal and recorded. The absolute accuracy of temperature logging instruments is not high (in the order of $\pm 5^{\circ}\text{F}$), but the resolution is good (0.05°F or better), although this accuracy can be compromised by present day digitalization of the signal on the surface. The temperature instrument usually can be included in the string with other tools, such as radioactive tracer tools or spinners flowmeters. Temperature logs are run continuously, typically at cable speeds of 20 to 30 ft/min.

Temperature logging is anticipated to be collected at the same time as oxygen activation logging. The proposed plan for logging is as follows:

1. Logging crew to arrive on location, hold safety meeting with all parties that will be present during operation prior to beginning any work.
2. Move-in and spot wireline unit and crane.
3. Perform lifting plan and validate with crew and client.
4. Verify wellhead connection and wellhead pressure to be zero before install packoff.
5. Logging crew to rig up PNX-PBMS tool string and packoff.
6. Pressure test to 3k PSI to verify the equipment integrity.
7. Surface check on tools prior to run in hole(RIH). Minitron NOT to be turned on at surface at any time.
8. RIH to 1000 ft and turn on minitron, perform a test log to verify tool is operational, once completed turn off minitron and continue RIH with tool on logging GR-CCL.
9. RIH to TD power on minitron and wait for tool stabilization.
10. Once stable, begin main pass at 900 ft/hr in GSH-Commercial mode GR-CCL-Temp-Press.
11. Log up to 500 ft “confirm logging interval with client at well-site”.
12. Once main pass completed, RIH and perform a repeat pass 200 ft.
13. Upon logging completion turn off minitron and wait below 200 ft for at least 30 minutes before pulling out of hole (POOH).
14. Upload data and confirm data integrity with Domain Champion prior to rigging down.
15. POOH and rig down tools.

3.11 Oxygen activation logging

Oxygen activation log (OAL) provides formation evaluation and reservoir monitoring in cased holes. OALs are deployed as a wireline logging tool with an electronic pulsed neutron source and one or more detectors that typically measure neutrons or gamma rays. High-speed digital signal electronics process the gamma ray response and its time of arrival relative to the start of the neutron pulse. Spectral analysis algorithms translate the gamma ray energy and time relationship into concentrations of elements. Each logging company has its own proprietary designs and improvements on the tool.

Schlumberger's Pulsar Multifunction Spectroscopy Service (PNX) pairs multiple detectors with a high output pulsed neutron generator in a slim tool with an outer diameter (o.d.) of 1.72 in. for through-tubing access in cased hole environments. The housing is corrosion-resistant, allowing deployment in wellbore environments such as CO₂. The tool's integration of the high neutron output and fast detection of gamma rays with proprietary pulse processing electronics, allows to differentiate and quantify gas-filled porosity from liquid-filled and tight zones. The tool can accurately determine saturation in any formation water salinity across a wide range of well conditions, mineralogy, lithology, and fluid contents profile at any inclination. Detection limits for CO₂ saturation for the PNX tool vary with the logging speed as well as the formation porosity. Detailed measurement and mechanical specifications for the PNX tool are provided in the QASP document. The wireline operator will provide QA/QC procedures and tool calibration for their equipment.

Haliburton's RMT-D reservoir monitor tool: The Halliburton Reservoir Monitor Tool 3-Detector™ (RMT-3D™) pulsed-neutron tool solves for water, oil, and gas saturations within reservoirs using three independent measurements (Sigma, C/O, and SATG). This provides the ability to uniquely solve simple or complex saturation profiles in reservoirs, while eliminating phase-saturation interdependency. The RMT-#D provides gas phase analysis to identify natural gases, nitrogen, CO₂, steam, and air. The tool has 2.125 in diameter OD that allows it to be run through tubing.

Temperature logging is anticipated to be collected at the same time as oxygen activation logging. The proposed plan for logging is as follows:

1. Logging crew to arrive on location, hold safety meeting with all parties that will be present during operation prior to beginning any work.
2. Move-in and spot wireline unit and crane.
3. Perform lifting plan and validate with crew and client.
4. Verify wellhead connection and wellhead pressure to be zero before install packoff.
5. Logging crew to rig up PNX-PBMS tool string and packoff.
6. Pressure test to 3k PSI to verify the equipment integrity.

7. Surface check on tools prior to run in hole(RIH). Minitron NOT to be turned on at surface at any time.
8. RIH to 1000 ft and turn on minitron, perform a test log to verify tool is operational, once completed turn off minitron and continue RIH with tool on logging GR-CCL.
9. RIH to TD power on minitron and wait for tool stabilization.
10. Once stable, begin main pass at 900 ft/hr in GSH-Commercial mode GR-CCL-Temp-Press.
11. Log up to 500 ft “confirm logging interval with client at well-site”.
12. Once main pass completed, RIH and perform a repeat pass 200 ft.
13. Upon logging completion turn off minitron and wait below 200 ft for at least 30 minutes before pulling out of hole (POOH).
14. Upload data and confirm data integrity with Domain Champion prior to rigging down.
15. POOH and rig down tools.

3.12 Fluid level testing

OLCV will utilize an echometer to obtain a fluid level in the injector wells. The echometer tool contains a small chamber that is loaded with compressed CO₂ or N₂. The tool is charged to a pressure greater than the well pressure and connected to the well via an appropriately rated hose. A valve is then opened allowing a pressure pulse to be expelled into the well. This acoustic pulse travels through the gas in the borehole. Some of the energy is reflected back by well construction materials: tubing collars, tubing anchors, perfs, and other downhole jewelry. The remaining pulse energy is reflected by the gas/liquid interface at the depth of the fluid level. The reflected signals are detected by microphones at the surface. A calculation is then performed to determine the depth of the fluid level based upon the speed required to travel downhole, reflect off the gas/fluid interface and return to surface.

4. SLR Monitoring Wells – Pre-Op Strategy

The Injection Zone for the BRP Project will be monitored by two Injection Zone Monitoring wells (SLR2 and SLR3). The SLR2 will be drilled prior to the commencement of CO₂ injection operations. The SLR3 will be drilled after operation injections commence, and its location may be refined based on updated AoR information. In addition to SLR wells, the Injection Zone will be monitored with data collected in four Water Withdrawal wells (WW).

Data collected in the water withdrawal wells (constructed and tested in Spring 2024) indicates an absence of permeable zones between the upper confining zone and the lowermost USDW. Therefore, the lowermost USDW is coincident with the first permeable zone above the confining zone. The lowermost USDW will be monitored by the USDW1 well.

The Shoe Bar 1 stratigraphic test well will be plugged above the Injection Zone prior to the commencement of CO₂ injection. The portion of the well above the Injection Zone contains

DTS/DAS fiber that may be used during VSP seismic acquisition and for monitoring pressure and temperature above the confining zone. The Shoe Bar 1 AZ will be plugged above the Injection Zone prior to the commencement of CO₂ injection. The confining zone integrity will be monitored in this well.

The need for additional monitoring wells will be considered during AoR re-evaluations, and at least every five years following commencement of injection. The locations and timing of monitor wells is discussed in the AoR and Corrective Action Plan.

4.1 Logging Program

4.1.1 Logs in SLR monitoring wells

See Section 3 of this document for a description of the data collected in the Shoe Bar 1 (SLR1) and Shoe Bar 1AZ (ACZ1) wells. The log data listed in the table below is planned for collection in the SLR2 and SLR3 wells.

Table 15—Logging program for SLR2 and SLR3 monitoring wells

Method	Interval (ft)	Purpose
Open Hole Logs, Surveys and Sampling During Construction		
Deviation survey	Every 100 ft while drilling as minimum, from surface to TD	Define well trajectory, displacement, and tortuosity
Wireline – Spontaneous Potential	Production	Correlation log, volume of shale indicator, estimate salinity
Wireline – Gamma ray	Production	Define stratigraphy, correlation log, shale indicator
Wireline – Resistivity	Production	Fluid identification, estimate salinity, correlation log
Wireline – Caliper	Production	Identify borehole enlargement and calculate cement volume
Wireline – Sonic Scanner	Production	Estimate mechanical properties, validation of velocity model, well tie to seismic
Wireline – Spectral gamma ray	Production	Define uranium rich formation, clay indicator
Wireline – Density / Neutron	Production	Estimate porosity, mineralogical characterization.
Wireline – Formation dynamics testing	Production	Measure formation pressures, fluid sampling
Mud Logging	Surface to TD (every 30 ft)	Identify lithology, hydrocarbon shows, gases composition

Cased Hole Logs and surveys Before Injection		
CBL-VDL-USIT-CCL	Surface, Intermediate, Production	Cement bond, casing integrity. Validate external mechanical integrity
Annulus Pressure Test – Long string casing	Annular between tubing and long string.	Validate internal mechanical integrity between the tubing, long string, and packer
Wireline – Activate pulsed neutron, through tubing	Surface, Intermediate, Production	CO ₂ saturation, baseline for monitoring
Wireline – Casing Inspection Tool	Surface, Intermediate, Production	Wall thickness, corrosion, ovality of tubulars. Validate external mechanical integrity. Baseline for monitoring
Fiber Optic – DTS survey	Surface, Intermediate, Production	Measure baseline temperature profile on the well from surface to top of perforation. Acquire baseline 3D VSP survey for monitoring plume migration over time

The logs listed in Table 15 will be conducted on the SLR2 and SLR3 wells.

4.2 Coring Program

Whole core and sidewall cores were collected in the Shoe Bar 1 and Shoe Bar 1AZ wells. The Project does not intend to acquire any additional core in future monitoring wells.

4.3 Formation Fluid Characterization Program

4.3.1 Acquisition

The BRP Project will utilize an MDT tool to acquire reservoir fluid samples from the zones being monitored in the SLR2 and SLR3 wells. The Project will obtain fluid samples from the Lower San Andres (up to six samples, subject to change). The final sample acquisition depths in these monitoring wells will be determined based on the petrophysical analysis of the open hole logs run prior to the MDT logging run.

Fluid samples were collected by an MDT tool in the water withdrawal wells, WW1, WW2, WW3 and WW4, during construction. See Section 6.3 for additional details on fluid sampling in these wells.

4.3.2 Analysis and Reporting

The fluid sample containers will be transported under pressure to a third-party lab for comprehensive analysis of fluid and dissolved. See Table 16 for the analytical methods and QC parameters for fluid and dissolved gas analyses.

Table 16–Summary of analytical parameters for fluid and dissolved gas samples in the Injection Zone (Lower San Andres).

Laboratory Analyte	Analytical Methods ¹	Detection Limit / Range ²	Typical Precision ²	QC Requirements
<u>Total and Dissolved Metals:</u> Ag, Al, As, Ba, Cd, Co, Cr, Cu, Mn, Mo, Ni, Pb, Sb, Se, Sr, Th, Tl, U, V, and Zn	USEPA Method 200.8	0.00004 to 0.003 mg/L	±20	Daily calibration, Initial QC checks (ICV, ICB, RL) method blank, lab control samples, matrix spikes and sample duplicate, CCV/CCB every 10 samples or part thereof
Total and Dissolved Metals: B, Ca, Fe, K, Mg, Li, Na, Si, Sr, Ti	USEPA Method 200.7	0.003 to 0.254 mg/L	±20	Daily calibration, Initial QC checks (IPC, ICV, ICB, RL) method blank, lab control samples, matrix spike and matrix spike dup; CCV/CCB every 10 samples or part thereof
Total and Dissolved Hg	USEPA Method 245.7	19.6 ng/L	±20	Calibration as needed, daily QC checks; ICV, ICB, RL, method blank, lab control samples, matrix spike and matrix spike dup; CCV/CCB every 10 samples or part thereof
Dissolved Inorganic Carbon (DIC); Dissolved Organic Carbon (DOC)	Standard Method 5310C	0.198 to 0.290 mg/L	±20	Calibration as needed, daily QC checks; ICV, ICB, RL, method blank, lab control samples, matrix spike and matrix spike dup; CCV/CCB every 10 samples or part thereof
Dissolved CO ₂	Standard Method 4500 CO ₂ D	8 mg/L	±20	Frequent calibration, method blank, lab control samples, matrix spikes and sample duplicate.
Alkalinity: Total, Bicarbonate, Carbonate, and Hydroxide	Standard Method 2320B	8 mg/L	±20	method blank, lab control samples, matrix spikes
Major Anions: Br, Cl, F, and SO ₄ , NO ₂ and NO ₃ as N	USEPA Method 300.0	0.003 to 0.563 mg/L	±20	Calibration as needed, daily QC checks; ICV, ICB, RL, method blank, lab control samples, matrix spike and matrix spike dup; CCV/CCB every 10 samples or part thereof
PO ₄ as P	USEPA Method 365.1	0.0215 mg/L	±20	Daily calibration, Initial QC checks (ICV, ICB, RL) method blank, lab control samples, matrix spikes and sample duplicate, CCV/CCB every 10 samples or part thereof

Dissolved H ₂ S (Sulfide)	Standard Method 4500S2-D	0.026 mg/L	±20	Calibration as needed, daily QC checks; ICV, ICB, RL, method blank, lab control samples, matrix spike and matrix spike dup
Total Dissolved Solids (TDS)	USEPA Method 160.1	10 mg/L	±20	Method blank, lab control samples, and sample duplicate
Conductivity	Standard Method 2510B	0 to 200 mS/cm	±1%	Calibration as needed, daily QC checks (1413, 14130 and second source SRM), CCV every 10 samples or part thereof
pH and Temperature	USEPA Method 150.1	0.1 to 14 pH units	±0.1 pH units	Daily calibration, second source SRM, CCV's every 10 samples or part thereof
Specific Gravity	ASTM Method D1429-03	NA	To the nearest thousandths decimal	Duplicates
Cation Anion Balance	Calculation	NA	±10	Calculation
Dissolved Gas Abundances: CO ₂ , CO, N ₂ , Ar, He, H ₂ , O ₂ , C1-C6+	In-house Lab SOP, similar to RSK-175	1 to 100 ppm, varies by component	C1-C4: ± 5%; C5-C6+: ± 10%	20% of all analyses are check/reference standards.
Dissolved Gas Isotopes: δ ¹³ C of C1-C5 and CO ₂ , δ ² H of C1	High precision (offline) analysis via Dual Inlet IRMS	Varies by component	δ ¹³ C: 0.1 per mil; δ ² H: 3.5 per mil	20% of all analyses are check/reference standards.
¹⁴ C of C1	AMS - subcontracted to Beta Analytic	0.44 pMC	± 1 to 2 pMC	Daily monitoring of instrumentation and chemical purity in additional to extensive computer and human cross-checks.
¹⁴ C of DIC	AMS - subcontracted to Beta Analytic	Depends on available sample volume	± 1 to 2 pMC	Daily monitoring of instrumentation and chemical purity in additional to extensive computer and human cross-checks.
δ ¹³ C of DIC	Gas Bench/CF-IRMS	Depends on available sample volume, minimum of 50mg/L required	0.20 per mil	20% of all analyses are either check/reference standards or duplicate analyses.
δ ¹⁸ O and δ ² H of H ₂ O	Analyzed via CRDS	N/A	δ ¹⁸ O: 0.10 per mil; δ ² H: 2.0 per mil	20% of all analyses are either check/reference standards or duplicate analyses.
⁸⁷ Sr/ ⁸⁶ Sr	TIMS - subcontracted	Approximately 40 ppm	± 0.00002	SRM 987 Sr standard within the long-term precision

Plan revision number: 3

Plan revision date: 07/30/2024

	to the University of AZ			(external precision) of +/- 0.00002 accepted value of 0.71025
²²⁸ Ra/ ²²⁶ Ra	USEPA Method 901.1	50 pCi/L (RL)	± 25%	Frequent calibration, method blank, lab control samples, matrix spikes and sample duplicate.
Field Parameters				
pH (Field)	Standard Method 24500-H+ B-2000	2 to 12 pH units	±0.2 pH units	User calibration per manufacturer recommendation
Specific conductance (Field)	EPA Method 120.1	0 to 200 mS/cm	±1%	User calibration per manufacturer recommendation
Temperature (Field)	Standard Method 2550 B-2000	-5 to 50 °C	±0.2 °C	Factory calibration
Oxidation-Reduction Potential (Field)	Standard Method 2580	-1999 to +1999 mV	±20 mV	User calibration per manufacturer recommendation
Dissolved Oxygen (Field)	ASTM Method D888-09 (C)	0 to 50 mg/L	0 to 20 mg/L: ±0.1 mg/L or 1% of reading, whichever is greater; 20 – 50 mg/L: ±8% of reading	User calibration per manufacturer recommendation
Turbidity (Field)	USEPA Method 180.1	0 to 1000 NTU	± 1% of reading or 0.01 NTU, whichever is greater	User calibration per manufacturer recommendation

¹An equivalent method may be employed with the prior approval of the UIC Program Director.

²Detection limits and precision (laboratory control limits) are typical for these analytical methods.

* Analytical parameters to be included during the pre-injection phase, and only as needed during the injection and post-injection phases of the Project.

4.4 Fracture Pressure

Fracture pressure was obtained in the Shoe Bar 1 and Shoe Bar 1AZ and will be obtained in the CO₂ injection wells. No fracture pressure measurements area planned for the SLR2 or SLR3 wells.

4.5 Well Mechanical Integrity

4.5.1 Mechanical Integrity Testing (MIT)

The BRP Project will conduct both internal and external mechanical integrity tests on the SLR2 and SLR3 wells. Internal mechanical integrity refers to the absence of leaks in the casing by tubing annulus, the tubing, and the packer. External mechanical integrity refers to the absence of formation fluid or CO₂ movement through channels in the cement on the exterior of the casing.

Upon completion and installation of the downhole equipment in the wells, BRP will conduct an APT to verify internal mechanical integrity. The APT is a short-term pressure test (30 minutes) where the well is shut in and the fluid in the annulus is pressurized to a predetermined pressure and is monitored for leak off. BRP will use a test pressure of 500 psi for the MIT's. BRP will use a 5% decrease in pressure (test pressure x .05) from the stabilized test pressure during the duration of the test to determine if test is successful. If the annulus pressure decreases by $\geq 5\%$, the well will have failed the APT. If a well fails an APT, the test will be repeated. If the APT is again failed, the downhole equipment will be removed from the well and the source of the failure will be investigated. The proposed procedure will be as follows:

1. Connect a high-resolution pressure transducer to the annulus casing valve and increase the annulus pressure to 500 psi and hold this pressure for 30 minutes.
2. At the conclusion of the 30-minute test the annulus pressure will be bled off to 0 psi and the pressure recording equipment will be removed from the casing valve.

Upon well completion, BRP will run cased hole logs to demonstrate external mechanical integrity of the casing and cement sheath prior to the start-up of operations. BRP will acquire baseline temperature logs to demonstrate a lack of fluid movement through channels or communication paths through the tubing or annulus. BRP will also run an ultrasonic imaging tool (USIT) to provide further confidence that there are no channels in the cement sheath for formation fluids or CO₂ to migrate upwards in the well.

5. USDW Monitoring Well

The Dockum group is the lowermost Underground Source of Drinking Water. Maps and additional stratigraphic details for the USDWs are included in the "Area of Review and Corrective Action Plan" document in Section 2.2.8 and in Section 2.4 of Appendix B to the AoR document. The USDW1 well was drilled in late 2023 and completed in early 2024. The dedicated purpose of this well is to monitor the Dockum group.

Although the shallow Pecos Valley alluvium is considered a USDW, it is generally not productive of water near the BRP Project. There are no current or planned wells in the AoR or near the AoR targeting the Pecos Valley alluvium.

5.1 Logging Program

Table 17 shows the logging and surveys conducted in the USDW monitoring well.

Table 17--Logs collected in the USDW-level well

Method	Interval (ft)	Purpose
Open Hole Logs, Surveys and Sampling During Construction		
Deviation survey	Every 100 ft while drilling as minimum, from surface to TD	Define trajectory, displacement, and tortuosity
Wireline – Spectral gamma ray	Surface to TD	Define uranium rich formation, clay indicator
Wireline- Spontaneous Potential	Surface to TD	Correlation log, volume of shale indicator, estimate salinity
Wireline –Resistivity	Surface to TD	Fluid identification, estimate salinity, correlation log
Wireline – Density / Neutron	Surface to TD	Estimate porosity, mineralogical characterization
Wireline – Caliper	Surface to TD	Identify borehole enlargement and calculate cement volume

5.2 Formation Fluid Characterization Program

5.2.1 Acquisition

The Project will monitor the chemical composition of the fluids and dissolved gases in the lowermost USDW, the Dockum group. A fluid sample was collected during well construction. The results are presented in Section 5.0 of Appendix A to the AoR document. Baseline samples will be collected on a quarterly basis for approximately one year prior to the start of injection. Baseline data collection will commence in June 2024. These samples will be collected by a qualified environmental monitoring and service provider and overseen by Oxy or OLCV personnel.

5.2.2 Analysis and Reporting

Table 18 includes the analysis that will be performed by the qualified environmental service provider and verified by Oxy or OLCV personnel.

Table 18-- Summary of analytical parameters for fluid and dissolved gas samples in the USDW (Dockum group)

Laboratory Analyte	Analytical Methods ¹	Detection Limit / Range ²	Typical Precision ²	QC Requirements
<u>Total and Dissolved Metals:</u> Ag, Al, As, Ba, Cd, Co, Cr, Cu, Mn, Mo, Ni, Pb, Sb, Se, Sr, Th, Tl, U, V, and Zn	USEPA Method 200.8	0.00004 to 0.003 mg/L	±20	Daily calibration, Initial QC checks (ICV, ICB, RL) method blank, lab control samples, matrix spikes and sample duplicate, CCV/CCB every 10 samples or part thereof

Total and Dissolved Metals: B, Ca, Fe, K, Mg, Li, Na, Si, Sr, Ti	USEPA Method 200.7	0.003 to 0.254 mg/L	±20	Daily calibration, Initial QC checks (IPC, ICV, ICB, RL) method blank, lab control samples, matrix spike and matrix spike dup; CCV/CCB every 10 samples or part thereof
Total and Dissolved Hg	USEPA Method 245.7	19.6 ng/L	±20	Calibration as needed, daily QC checks; ICV, ICB, RL, method blank, lab control samples, matrix spike and matrix spike dup; CCV/CCB every 10 samples or part thereof
Dissolved Inorganic Carbon (DIC); Dissolved Organic Carbon (DOC)	Standard Method 5310C	0.198 to 0.290 mg/L	±20	Calibration as needed, daily QC checks; ICV, ICB, RL, method blank, lab control samples, matrix spike and matrix spike dup; CCV/CCB every 10 samples or part thereof
Dissolved CO ₂	Standard Method 4500 CO ₂ D	8 mg/L	±20	Frequent calibration, method blank, lab control samples, matrix spikes and sample duplicate.
Alkalinity: Total, Bicarbonate, Carbonate, and Hydroxide	Standard Method 2320B	8 mg/L	±20	method blank, lab control samples, matrix spikes
Major Anions: Br, Cl, F, and SO ₄ , NO ₂ and NO ₃ as N	USEPA Method 300.0	0.003 to 0.563 mg/L	±20	Calibration as needed, daily QC checks; ICV, ICB, RL, method blank, lab control samples, matrix spike and matrix spike dup; CCV/CCB every 10 samples or part thereof
PO ₄ as P	USEPA Method 365.1	0.0215 mg/L	±20	Daily calibration, Initial QC checks (ICV, ICB, RL) method blank, lab control samples, matrix spikes and sample duplicate, CCV/CCB every 10 samples or part thereof
Dissolved H ₂ S (Sulfide)	Standard Method 4500S2-D	0.026 mg/L	±20	Calibration as needed, daily QC checks; ICV, ICB, RL, method blank, lab control samples, matrix spike and matrix spike dup
Total Dissolved Solids (TDS)	USEPA Method 160.1	10 mg/L	±20	Method blank, lab control samples, and sample duplicate
Conductivity	Standard Method 2510B	0 to 200 mS/cm	±1%	Calibration as needed, daily QC checks (1413, 14130 and second source SRM),

				CCV every 10 samples or part thereof
pH and Temperature	USEPA Method 150.1	0.1 to 14 pH units	±0.1 pH units	Daily calibration, second source SRM, CCV's every 10 samples or part thereof
Specific Gravity	ASTM Method D1429-03	NA	To the nearest thousandths decimal	Duplicates
Cation Anion Balance	Calculation	NA	±10	Calculation
Dissolved Gas Abundances: CO ₂ , CO, N ₂ , Ar, He, H ₂ , O ₂ , C1-C6+	In-house Lab SOP, similar to RSK-175	1 to 100 ppm, varies by component	C1-C4: ± 5%; C5-C6+: ± 10%	20% of all analyses are check/reference standards.
Dissolved Gas Isotopes: δ ¹³ C of C1-C5 and CO ₂ , δ ² H of C1	High precision (offline) analysis via Dual Inlet IRMS	Varies by component	δ ¹³ C: 0.1 per mil; δ ² H: 3.5 per mil	20% of all analyses are check/reference standards.
¹⁴ C of C1	AMS - subcontracted to Beta Analytic	0.44 pMC	± 1 to 2 pMC	Daily monitoring of instrumentation and chemical purity in addition to extensive computer and human cross-checks.
¹⁴ C of DIC	AMS - subcontracted to Beta Analytic	Depends on available sample volume	± 1 to 2 pMC	Daily monitoring of instrumentation and chemical purity in addition to extensive computer and human cross-checks.
δ ¹³ C of DIC	Gas Bench/CF-IRMS	Depends on available sample volume, minimum of 50mg/L required	0.20 per mil	20% of all analyses are either check/reference standards or duplicate analyses.
δ ¹⁸ O and δ ² H of H ₂ O	Analyzed via CRDS	N/A	δ ¹⁸ O: 0.10 per mil; δ ² H: 2.0 per mil	20% of all analyses are either check/reference standards or duplicate analyses.
⁸⁷ Sr/ ⁸⁶ Sr	TIMS - subcontracted to the University of AZ	Approximately 40 ppm	± 0.00002	SRM 987 Sr standard within the long-term precision (external precision) of +/- 0.00002 accepted value of 0.71025
²²⁸ Ra/ ²²⁶ Ra	USEPA Method 901.1	50 pCi/L (RL)	± 25%	Frequent calibration, method blank, lab control samples, matrix spikes and sample duplicate.
Field Parameters				
pH (Field)	Standard Method 24500-H+ B-2000	2 to 12 pH units	±0.2 pH units	User calibration per manufacturer recommendation

Specific conductance (Field)	EPA Method 120.1	0 to 200 mS/cm	±1%	User calibration per manufacturer recommendation
Temperature (Field)	Standard Method 2550 B-2000	-5 to 50 °C	±0.2 °C	Factory calibration
Oxidation-Reduction Potential (Field)	Standard Method 2580	-1999 to +1999 mV	±20 mV	User calibration per manufacturer recommendation
Dissolved Oxygen (Field)	ASTM Method D888-09 (C)	0 to 50 mg/L	0 to 20 mg/L: ±0.1 mg/L or 1% of reading, whichever is greater; 20 – 50 mg/L: ±8% of reading	User calibration per manufacturer recommendation
Turbidity (Field)	USEPA Method 180.1	0 to 1000 NTU	± 1% of reading or 0.01 NTU, whichever is greater	User calibration per manufacturer recommendation

¹An equivalent method may be employed with the prior approval of the UIC Program Director.

²Detection limits and precision (laboratory control limits) are typical for these analytical methods.

* Analytical parameters to be included during the pre-injection phase, and only as needed during the injection and post-injection phases of the Project.

5.3 Well Mechanical Integrity

Per Texas Water Development Board, mechanical integrity testing is not required for the USDW1 monitoring well.

6. Water Withdrawal Wells

BRP Project has constructed four water withdrawal wells in Spring 2024. The purpose of these wells is to remove brine from the Injection Zone for pressure management. The Project collected logs and fluid samples in these wells. Preliminary results are presented in Section 5.2 of Appendix A to the AoR document.

6.1 Logging Program

The table below shows the logging and surveys for the water withdrawal wells.

Table 19--Logging, survey, and sampling program for water withdrawal wells

Method	Interval Section(s)	Purpose
Open Hole Logs, Surveys and Sampling During Construction		
Deviation survey	Every 100 ft while drilling as minimum, from surface to TD	Define well trajectory, displacement, and tortuosity
Wireline- Spontaneous Potential	Production	Correlation log, volume of shale indicator, estimate salinity
Wireline – Resistivity	Production	Fluid identification, estimate salinity, correlation log
Wireline – Caliper	Production	Identify borehole enlargement and calculate cement volume
Wireline -Gamma ray	Production	Define stratigraphy, correlation log, shale indicator
Wireline -Sonic Scanner	Production	Estimate mechanical properties, validation of velocity model, well tie to seismic
Wireline - Spectral gamma ray	Production	Define uranium rich formation, clay indicator
Wireline - Density / Neutron	Production	Estimate porosity, mineralogical characterization
Wireline - Formation Dynamics Testing	Production	Fluid sampling, estimate Kv/Kh*
Wireline – Magnetic resonance image**	Production	Estimate porosity, pore size distribution, permeability index
Cased Hole Logs		
Wireline - CBL-VDL-USIT-CCL	Surface, Intermediate, Production	Cement bond, casing integrity. Validate external mechanical integrity
Wireline – Temperature Log	Surface, Intermediate, Production	Measure baseline temperature profile on the well
Annulus Pressure Test - Long string casing	Annular between tubing and long string	Validate internal mechanical integrity between the tubing, long-string, and packer
Wireline - Activate pulsed neutron – Long string casing	Intermediate, Production	CO ₂ saturation, baseline for monitoring

* - Vertical interference testing performed in SBR 1WW and SBR 2WW only, for estimation of Kv/Kh

** - Magnetic resonance log only run in SBR 2WW and SBR 3WW

The logs listed in Table 19 were conducted in the water withdrawal wells.

6.2 Coring Program

No core was collected in the water withdrawal wells.

6.3 Formation Fluid Characterization Program

The BRP Project utilized an MDT tool to acquire reservoir fluid samples in the water withdrawal wells during construction to capture baseline fluid properties and chemistry. BRP Project is awaiting the geochemical results of water samples obtained from the Injection Zone.

The BRP Project attempted to acquire reservoir fluid samples above the upper confining zone and below the lowermost USDW, however these zones were tight. See Section 5.2 of Appendix A to the AoR document for details on sampling above the confining zone.

6.4 Fracture Pressure

No fracture pressure measurements were collected in the water withdrawal wells.

6.3 Well Mechanical Integrity

The BRP Project conducted both internal and external mechanical integrity tests on four water withdrawal wells. Internal mechanical integrity refers to the absence of leaks in the casing by tubing annulus, the tubing, and the packer. External mechanical integrity refers to the absence of formation fluid or CO₂ movement through channels in the cement on the exterior of the casing.

Upon the completion of drilling of the four water withdrawal wells and prior to perforating, BRP conducted an internal mechanical integrity test (MIT) to confirm wellbore mechanical integrity. The MIT is a short-term pressure test (30 minutes) where the internal wellbore is loaded with fluid and pressured up to a predetermined pressure and is monitored for leak-off. BRP used a test pressure of 500 psi for the MITs. BRP used a 5% decrease in pressure (test pressure x .05) from the stabilized test pressure during the duration of the test to determine if test is successful. If the annulus pressure had decreased by $\geq 5\%$, the well would have failed the internal MIT. None of the four water withdrawal wells failed their MIT.

The procedure was:

1. Connect a high-resolution pressure transducer to the annulus casing valve and increase the annulus pressure to 500 psi and hold this pressure for 30 minutes.
2. At the conclusion of the 30-minute test the annulus pressure will be bled off to 0 psi and the pressure recording equipment will be removed from the casing valve.

Plan revision number: 3

Plan revision date: 07/30/2024

Upon the completion of drilling, BRP conducted cased hole logs to demonstrate external mechanical integrity of the casing and cement sheath prior to the start-up of operations. BRP acquired baseline temperature logs to demonstrate a lack of fluid movement through channels or communication paths through the tubing or annulus. BRP conducted an ultrasonic imaging tool (USIT) to provide further confidence that there are no channels in the cement sheath for formation fluids or CO₂ to migrate upwards in the well.

7. **References**

Talley, G. R., Swindell, T. M., Waters, G. A., and K. G. Nolte. 1999. Field Application of After-Closure Analysis of Fracture Calibration Tests. Paper presented at the SPE Mid-Continent Operations Symposium, Oklahoma City, Oklahoma, March 1999. doi: <https://doi.org/10.2118/52220-MS>

EPA. 2002. UIC Pressure Falloff Testing Guideline, EPA Region 6, 2 Aug. 2002. <https://www.epa.gov/sites/default/files/2015-07/documents/guideline.pdf>. Accessed 30 Oct. 2023.

Petrowiki. 2016. Diagnostic Plots. Society of Petroleum Engineers. petrowiki.spe.org/Diagnostic_plots.

E. INJECTION WELL OPERATING CONDITIONS

SUMMARY OF OPERATING CONDITIONS
16 TAC 5.206(d)(2)

Brown Pelican CO₂ Sequestration Project

1.0 Facility Information 1
2.0 Injection Well Operating Conditions 1
3.0 Reporting Frequencies 3
4.0. Operations 5

1.0 Facility Information

Facility name: Brown Pelican CO₂ Sequestration Project
BRP CCS1 Well

Facility contact: [REDACTED]
[REDACTED]
[REDACTED]

Well location: Penwell, Texas
31.76481926, -102.72891895

2.0 Injection Well Operating Conditions

UIC Class VI injection well operating and project reporting requirements for the Brown Pelican CO₂ Sequestration Project (BRP Project or Project) are specified in this document and summarized below in Table 1. The operating conditions summarized in this document were determined based on data collected in the BRP CCS1 injector well and updated from previous operating conditions based on data collected in Shoe Bar 1AZ stratigraphic test well.

Table 1—UIC Class VI Injection Well Operating Conditions

Parameter/ Condition	BRP CCS1: Updated Permit Value	Units
Daily maximum injection mass	1,040	Metric tons per day
Daily average injection mass	572	Metric tons per day
Daily maximum injection rate	20	Million standard cubic feet per day
Daily average injection rate	11	Million standard cubic feet per day
Total mass	2.50	Million metric tons
Maximum injection mass	379,466	Metric tons per year
Average injection mass	208,706	Metric tons per year
Maximum surface wellhead injection pressure	2,342	Psig
Maximum bottomhole injection pressure	3,362	Psig
Minimum annulus pressure	100	psig
Minimum annulus pressure/ tubing differential	100	psig

Limitations or permitted values for the maximum surface wellhead injection pressure, maximum bottomhole injection pressure, minimum annulus pressure, and minimum annulus pressure/tubing differential limitation are set as follows:

- Maximum Surface Wellhead Injection Pressure [16 TAC 5.206(d)(2)(C)]:** CO₂ will be supplied by a dehydration and compression facility located approximately four miles northeast of the UIC Class VI injector well location. The pressure at the facility discharge will be between 1,800 psig and 2,800 psig. The CO₂ will then be routed via pipeline to valve stations near the UIC Class VI injection well. Here the pressure will be reduced prior to reaching the wellhead. Pressure at the well will be controlled via control choke valves with shutdown protocols in place to protect the well in the event of a high-pressure scenario. The maximum wellhead pressure was determined by modeling the daily maximum injection rate in the wellbore and reservoir.
- Maximum Bottomhole Injection Pressure:** The maximum pressure considered for the UIC Class VI injector well is 90% of the fracture opening pressure of the Injection Zone, measured using a downhole pressure gauge. The bottomhole pressure submitted in the initial permit application utilized Step Rate Test data collected in the Shoe Bar 1AZ stratigraphic test well (see Equation 1a). During construction of the UIC Class VI well, a mini-frac test was conducted. These data were used to determine the fracture pressure and revise the bottomhole pressure maximum limit (Equation 1b).

- The fracture pressure of the Injection Zone is determined from Step Rate Test data collected in the Shoe Bar 1AZ well that was drilled for the purposes of this Project. Reservoir modeling indicates the pore pressure required to move the effective stress state into tensile failure is near 2933 psi at a depth of 4,609 ft below the ground surface. Maximum downhole injection pressure is therefore set to be less than 90% of that 2,933 psi threshold, calculated as follows:

$$0.9 \times 2,933 = 2,640 \text{ psia} - 14.7 \text{ psi} = 2,625.3 \text{ psig} \quad \text{Equation 1a}$$

- During construction of the BRP CCS1, the fracture pressure of the Injection Zone was determined from a mini-frac test. Reservoir modeling indicates the pore pressure required to move the effective stress state into tensile failure is near 3,751.4 psi at a depth of 4,446 ft TVD (approximate depth of shallowest perforation). Maximum downhole injection pressure is therefore set to be less than 90% of 3,751.4 psi threshold, calculated as follows:

$$0.9 \times 3,751.4 = 3,376.3 \text{ psia} - 14.7 \text{ psi} = 3,361.6 \text{ psig} \quad \text{Equation 1b}$$

The initial submitted maximum bottomhole injection pressure in equation 1a was calculated based on logs and well information from the Shoe Bar 1AZ. The equation 1b represents the updated bottomhole injection pressure calculated based on data from the UIC Class VI injection well.

- **Minimum Annulus Pressure:** As necessary to prevent “burst” or “collapse” of the tubing, the minimum annulus pressure is calculated as follows:

$$\text{Collapse Pressure} = \text{depth} \times [(\text{pressure gradient of formation}) + (\text{pressure gradient of cement}) - (\text{pressure gradient of water})] \quad \text{Equation 2}$$

$$\text{Burst Pressure} = \text{depth} \times (\text{pressure gradient of injectant}) + \text{surface pressure} \quad \text{Equation 3}$$

- **Minimum Annulus Pressure/Tubing Differential:** The annulus pressure/tubing differential is measured directly above and across the injection packer and is set to be a minimum of 100 psi above the downhole tubing injection pressure.

If the downhole pressure gauge fails to function properly, then the maximum injection pressure shall immediately be limited by the maximum surface wellhead injection pressure until the downhole pressure gauge can be repaired or replaced.

3.0 Reporting Frequencies

Oxy Low Carbon Ventures, LLC (OLCV) will maintain the reporting frequencies as summarized below in Table 2.

Table 2—Class VI Reporting Frequencies

Activity	Minimum Reporting Frequency
Change to the CO ₂ stream characterization	Semi-annually
Monthly injection pressure, flow rate, volume, pressure on the annulus, annulus fluid level, and temperature (Min, Max, and Avg.)	Semi-annually
Corrosion monitoring	Semi-annually
Monthly and cumulative volume and mass of the carbon dioxide stream injected	Semi-annually
Monthly annulus fluid volume added	Semi-annually
Results and reports for the monitoring systems proposed: plume tracking, above confining zone monitoring, surface monitoring	Semi-annually
Description of any event that triggers a shutoff device and the response taken	Semi-annually
Description of any event that exceeds operating parameters for annulus pressure or injection pressure specified in the permit	Semi-annually
Any injectivity test performed in the well	Notification 30 days before and results within 30 days of completion of test
External Mechanical Integrity Test (MIT) and internal MIT*	Notification 30 days before and results within 30 days of completion of test
Pressure falloff testing	Notification 30 days before and results within 30 days of completion of test
Planned workover or well stimulation	Notification 30 days before and results within 30 days of completion of test
Monitoring well MITs	Notification 30 days before and results within 30 days of completion of test
Financial responsibility updates pursuant to H.2 and H.3(a) of this permit	Within 60 days of update

*Note: The reporting frequency for MIT will comply with TAC Title 16 Chapter 5.206(e)(1): “The operator of an anthropogenic CO₂ injection well must maintain and comply with the approved monitoring, sampling, and testing plan to verify that the geologic storage facility is operating as permitted and that the injected fluids are confined to the injection zone.”

All testing and monitoring frequencies as well as methodologies are included in the Testing and Monitoring Plan document of this permit.

The events that trigger an immediate emergency response should be reported within 24 hours, according to the 16 TAC 5.207(A) reporting requirements.

4.0. Operations

During operations, including start-up, normal operations and shut-in operations, OLCV will maintain injection rates and pressures listed in Table 1. During start-up operations, injection rates will gradually increase to the planned rate. Injection rates will be reduced gradually during a planned shut-in.

- 16 TAC 5.206(d)(2)(E): Continuous recording devices will monitor surface and downhole pressure, rate, volume and temperature. The injection rates will be controlled with variable control chokes.
- 16 TAC 5.206(d)(2)(B): Volume will be measured and recorded using an orifice flowmeter.
- 16 TAC 5.206(d)(2)(F): Automatic alarms and automatic shutoff systems will be installed and maintained. Successful function of the alarm system and shutoff system will be demonstrated prior to injection and once annually thereafter.

At all times, pressure will be maintained on the well to prevent the return of the injection fluid to the surface. The wellbore will be filled with a high-specific-gravity fluid during workovers to maintain a positive (downward) gradient and/or a plug shall be installed that can resist the pressure differential. A blowout preventer must be installed and kept in proper operational condition whenever the wellhead is removed to work on the well.

OLCV will cease injection according to the guidelines provided below:

- OLCV shall cease injection should it appear that the well is lacking mechanical integrity or that the injected CO₂ stream and/or associated pressure front may cause an endangerment to a USDW.
- OLCV must shut in the well by gradual reduction of the injection pressure and rate as outlined in the Summary of Operating Conditions document of this permit; or
- OLCV must immediately cease injection and shut in the well as outlined in the Emergency and Remedial Response Plan document of this permit.

**SUMMARY OF OPERATING CONDITIONS: BRP CCS2
16 TAC 5.206(d)(2)**

Brown Pelican CO₂ Sequestration Project

1.0 Facility Information 1
2.0 Injection Well Operating Conditions 1
3.0 Reporting Frequencies 3
4.0. Operations 5

1.0 Facility Information

Facility name: Brown Pelican CO₂ Sequestration Project
BRP CCS2 Well

Facility contact: [REDACTED]
[REDACTED]
[REDACTED]

Well location: Penwell, Texas
31.76994887, -102.73320589

2.0 Injection Well Operating Conditions

UIC Class VI injection well operating and project reporting requirements for the Brown Pelican CO₂ Sequestration Project (BRP Project or Project) are specified in this document and summarized below in Table 1. The operating conditions summarized in this document were determined based on data collected in the BRP CCS2 and updated from previous operating conditions based on data collected in the Shoe Bar 1AZ stratigraphic test well.

Table 1—UIC Class VI Injection Well Operating Conditions

Parameter/ Condition	BRP CCS2: Updated Permit Value	Units
Daily maximum injection mass	1,196	Metric tons per day
Daily average injection mass	1,040	Metric tons per day
Daily maximum injection rate	23	Million standard cubic feet per day
Daily average injection rate	20	Million standard cubic feet per day
Total mass	4.55	Million metric tons
Maximum injection mass	436,386	Metric tons per year
Average injection mass	379,466	Metric tons per year
Maximum surface wellhead injection pressure	3,202	psig
Maximum bottomhole injection pressure	4,111	psig
Minimum annulus pressure	100	psig
Minimum annulus pressure/ tubing differential	100	psig

Limitations or permitted values for the maximum surface wellhead injection pressure, maximum bottomhole injection pressure, minimum annulus pressure, and minimum annulus pressure/tubing differential limitation are set as follows:

- Maximum Surface Wellhead Injection Pressure [16 TAC 5.206(d)(2)(C)]:** CO₂ will be supplied by a dehydration and compression facility located approximately four miles northeast of the CO₂ Injector well location. The pressure at the facility discharge will be between 1,800 psig and 2,800 psig. The CO₂ will then be routed via pipeline to valve stations near the UIC Class VI injection well. Here the pressure will be managed prior to reaching the wellhead. Pressure at the well will be controlled via control chokes valves with shutdown protocols in place to protect the well in the event of a high-pressure scenario. The maximum wellhead pressure was determined by modeling the daily maximum injection rate in the wellbore and reservoir.
- Maximum Bottomhole Injection Pressure:** The maximum pressure considered for the UIC Class VI injector well is 90% of the fracture opening pressure of the Injection Zone, measured using a downhole pressure gauge. The bottomhole pressure submitted in the initial permit application utilized Step Rate Test data collected in the Shoe Bar 1AZ stratigraphic test well (see Equation 1a). During construction of the UIC Class VI well, a mini-frac test was conducted. These data were used to determine the fracture pressure and revise the bottomhole pressure maximum limit (Equation 1b).

- The fracture pressure of the Injection Zone is determined from Step Rate Test data collected in the Shoe Bar 1AZ well that was drilled for the purposes of this Project. Reservoir modeling indicates the pore pressure required to move the effective stress state into tensile failure is near 3,785 psi at a depth of 5,115 ft below the ground surface. Maximum downhole injection pressure is therefore set to be less than 90% of that 3,785 psi threshold, calculated as follows:

$$0.9 \times 3,785 = 3,406.5 \text{ psia} - 14.7 \text{ psi} = 3,391.8 \text{ psig} \quad \text{Equation 1a}$$

- During construction of the BRP CCS2, the fracture pressure of the Injection Zone was determined from a mini-frac test. Reservoir modeling indicates the pore pressure required to move the effective stress state into tensile failure is near 4,583.7 psi at a depth of 5,093 ft TVD (approximate depth of shallowest perforation). Maximum downhole injection pressure is therefore set to be less than 90% of that 4,583.7 psi threshold, calculated as follows:

$$0.9 \times 4,583.7 = 4,125.3 \text{ psia} - 14.7 \text{ psi} = 4,110.6 \text{ psig} \quad \text{Equation 1b}$$

The initial submitted maximum bottomhole injection pressure in equation 1a was calculated based on logs and well information from the Shoe Bar 1AZ. The equation 1b represents the updated bottomhole injection pressure calculated based on data from the UIC Class VI injection well.

- **Minimum Annulus Pressure:** As necessary to prevent “burst” or “collapse” of the tubing, the minimum annulus pressure is calculated as follows:

$$\text{Collapse Pressure} = \text{depth} \times [(\text{pressure gradient of formation}) + (\text{pressure gradient of cement}) - (\text{pressure gradient of water})] \quad \text{Equation 2}$$

$$\text{Burst Pressure} = \text{depth} \times (\text{pressure gradient of injectant}) + \text{surface pressure} \quad \text{Equation 3}$$

- **Minimum Annulus Pressure/Tubing Differential:** The annulus pressure/tubing differential is measured directly above and across the injection packer and is set to be a minimum of 100 psi above the downhole tubing injection pressure.

If the downhole pressure gauge fails to function properly, then the maximum injection pressure shall immediately be limited by the maximum surface wellhead injection pressure until the downhole pressure gauge can be repaired or replaced.

3.0 Reporting Frequencies

Oxy Low Carbon Ventures, LLC (OLCV) will maintain the reporting frequencies as summarized below in Table 2.

Table 2—Class VI Reporting Frequencies

Activity	Minimum Reporting Frequency
Change to the CO ₂ stream characterization	Semi-annually
Monthly injection pressure, flow rate, volume, pressure on the annulus, annulus fluid level, and temperature (Min, Max, and Avg.)	Semi-annually
Corrosion monitoring	Semi-annually
Monthly and cumulative volume and mass of the carbon dioxide stream injected	Semi-annually
Monthly annulus fluid volume added	Semi-annually
Results and reports for the monitoring systems proposed: plume tracking, above confining zone monitoring, surface monitoring	Semi-annually
Description of any event that triggers a shutoff device and the response taken	Semi-annually
Description of any event that exceeds operating parameters for annulus pressure or injection pressure specified in the permit	Semi-annually
Any injectivity test performed in the well	Notification 30 days before and results within 30 days of completion of test
External Mechanical Integrity Test (MIT) and internal MIT*	Notification 30 days before and results within 30 days of completion of test
Pressure falloff testing	Notification 30 days before and results within 30 days of completion of test
Planned workover or well stimulation	Notification 30 days before and results within 30 days of completion of test
Monitoring well MITs	Notification 30 days before and results within 30 days of completion of test
Financial responsibility updates pursuant to H.2 and H.3(a) of this permit	Within 60 days of update

*Note: The reporting frequency for MIT will comply with TAC Title 16 Chapter 5.206(e)(1): “The operator of an anthropogenic CO₂ injection well must maintain and comply with the approved monitoring, sampling, and testing plan to verify that the geologic storage facility is operating as permitted and that the injected fluids are confined to the injection zone.”

All testing and monitoring frequencies as well as methodologies are included in the Testing and Monitoring Plan document of this permit.

The events that trigger an immediate emergency response should be reported within 24 hours, according to the 16 TAC 5.207(A) reporting requirements.

4.0. Operations

During operations, including start-up, normal, and shut-in operations, OLCV will maintain injection rates and pressures listed in Table 1. During start-up operations, injection rates will gradually increase to the planned rate. Injection rates will be reduced gradually during a planned shut-in.

- 16 TAC 5.206(d)(2)(E): Continuous recording devices will monitor surface and downhole pressure, rate, volume and temperature. The injection rates will be controlled with variable control chokes.
- 16 TAC 5.206(d)(2)(B): Volume will be measured and recorded using an orifice flowmeter.
- 16 TAC 5.206(d)(2)(F): Automatic alarms and automatic shutoff systems will be installed and maintained. Successful function of the alarm system and shutoff system will be demonstrated prior to injection and once annually thereafter.

At all times, pressure will be maintained on the well to prevent the return of the injection fluid to the surface. The wellbore will be filled with a high-specific-gravity fluid during workovers to maintain a positive (downward) gradient and/or a plug shall be installed that can resist the pressure differential. A blowout preventer must be installed and kept in proper operational condition whenever the wellhead is removed to work on the well.

OLCV will cease injection according to the guidelines provided below:

- OLCV shall cease injection should it appear that the well is lacking mechanical integrity or that the injected CO₂ stream and/or associated pressure front may cause an endangerment to a USDW.
- OLCV must shut in the well by gradual reduction of the injection pressure and rate as outlined in the Summary of Operating Conditions document of this permit; or
- OLCV must immediately cease injection and shut in the well as outlined in the Emergency and Remedial Response Plan document of this permit.

**SUMMARY OF OPERATING CONDITIONS: BRP CCS3
16 TAC 5.206(d)(2)**

Brown Pelican CO₂ Sequestration Project

1.0 Facility Information 1
2.0 Injection Well Operating Conditions 1
3.0 Reporting Frequencies 3
4.0 Operations 5

1.0 Facility Information

Facility name: Brown Pelican CO₂ Sequestration Project
BRP CCS3 Well

Facility contact: [REDACTED]
[REDACTED]
[REDACTED]

Well location: Penwell, Texas
31.76024766, -102.71013484

2.0 Injection Well Operating Conditions

UIC Class VI injection well operating and project reporting requirements for the Brown Pelican CO₂ Sequestration Project (BRP Project or Project) are specified in this document and summarized below in Table 1. The operating conditions summarized in this document were determined based on data collected in the BRP CCS3 injector well and updated from previous operating conditions based on data collected in the Shoe Bar 1AZ stratigraphic test well.

Table 1—UIC Class VI Injection Well Operating Conditions

Parameter/ Condition	BRP CCS3: Updated Permit Value	Units
Daily maximum injection mass	676	Metric tons per day
Daily average injection mass	468	Metric tons per day
Daily maximum injection rate	13	Million standard cubic feet per day
Daily average injection rate	9	Million standard cubic feet per day
Total mass	2.05	Million metric tons
Maximum injection mass	246,653	Metric tons per year
Average injection mass	170,760	Metric tons per year
Maximum surface wellhead injection pressure	1,568	psig
Maximum bottomhole injection pressure	2,830	psig
Minimum annulus pressure	100	psig
Minimum annulus pressure/ tubing differential	100	psig

Limitations or permitted values for the maximum surface wellhead injection pressure, maximum bottomhole injection pressure, minimum annulus pressure, and minimum annulus pressure/tubing differential limitation are set as follows:

- Maximum Surface Wellhead Injection Pressure [16 TAC 5.206(d)(2)(C)]:** CO₂ will be supplied by a dehydration and compression facility located approximately four miles northeast of the UIC Class VI injector well location. The pressure at the facility discharge will be between 1,800 psi and 2,800 psig. The CO₂ will then be routed via pipeline to valve stations near the injection well. Here the pressure will be reduced prior to reaching the wellhead. Pressure at the well will be controlled via control valves with shutdown protocols in place to protect the well in the event of a high-pressure scenario. The maximum wellhead pressure was determined by modeling the daily maximum injection rate in the wellbore and reservoir.
- Maximum Bottomhole Injection Pressure:** The maximum pressure considered for the UIC Class VI injector well is 90% of the fracture opening pressure of the Injection Zone, measured using a downhole pressure gauge. The bottomhole pressure submitted in the initial permit application utilized Step Rate Test data collected in the Shoe Bar 1AZ stratigraphic test well (see Equation 1a). During construction of the UIC Class VI well, a mini-frac test was conducted. These data were used to determine the fracture pressure and revise the bottomhole pressure maximum limit (Equation 1b).

- The fracture pressure of the Injection Zone is determined from Step Rate Test data collected in the Shoe Bar 1AZ well that was drilled for the purposes of this Project. Reservoir modeling indicates the pore pressure required to move the effective stress state into tensile failure is near 2933 psi at a depth of 4,609 ft below the ground surface. Maximum downhole injection pressure is therefore set to be less than 90% of that 2,933 psi threshold, calculated as follows:

$$0.9 \times 2,933 = 2,640 \text{ psia} - 14.7 \text{ psi} = 2,625.3 \text{ psig} \quad \text{Equation 1a}$$

- During construction of the BRP CCS3, the fracture pressure of the Injection Zone was determined from a mini-frac test. Reservoir modeling indicates the pore pressure required to move the effective stress state into tensile failure is near 3,160.9 psi at a depth of 4,452 ft TVD (approximate depth of shallowest perforation). Maximum downhole injection pressure is therefore set to be less than 90% of the 3,160.9 psi threshold, calculated as follows:

$$0.9 \times 3,160.9 = 2,844.8 \text{ psia} - 14.7 \text{ psi} = 2,830.1 \text{ psig} \quad \text{Equation 1b}$$

The initial submitted maximum bottomhole injection pressure in equation 1a was calculated based on logs and well information from the Shoe Bar 1AZ. The equation 1b represents the updated bottomhole injection pressure calculated based on data from the UIC Class VI injection well.

- **Minimum Annulus Pressure:** As necessary to prevent “burst” or “collapse” of the tubing, the minimum annulus pressure is calculated as follows:

$$\text{Collapse Pressure} = \text{depth} \times [(\text{pressure gradient of formation}) + (\text{pressure gradient of cement}) - (\text{pressure gradient of water})] \quad \text{Equation 2}$$

$$\text{Burst Pressure} = \text{depth} \times (\text{pressure gradient of injectant}) + \text{surface pressure} \quad \text{Equation 3}$$

- **Minimum Annulus Pressure/Tubing Differential:** The annulus pressure/tubing differential is measured directly above and across the injection packer and is set to be a minimum of 100 psi above the downhole tubing injection pressure.

If the downhole pressure gauge fails to function properly, then the maximum injection pressure shall immediately be limited by the maximum surface wellhead injection pressure until the downhole pressure gauge can be repaired or replaced.

3.0 Reporting Frequencies

Oxy Low Carbon Ventures, LLC (OLCV) will maintain the reporting frequencies as summarized below in Table 2.

Table 2—Class VI Reporting Frequencies

Activity	Minimum Reporting Frequency
Change to the CO ₂ stream characterization	Semi-annually
Monthly injection pressure, flow rate, volume, pressure on the annulus, annulus fluid level, and temperature (Min, Max, and Avg.)	Semi-annually
Corrosion monitoring	Semi-annually
Monthly and cumulative volume and mass of the carbon dioxide stream injected	Semi-annually
Monthly annulus fluid volume added	Semi-annually
Results and reports for the monitoring systems proposed: plume tracking, above confining zone monitoring, surface monitoring	Semi-annually
Description of any event that triggers a shutoff device and the response taken	Semi-annually
Description of any event that exceeds operating parameters for annulus pressure or injection pressure specified in the permit	Semi-annually
Any injectivity test performed in the well	Notification 30 days before and results within 30 days of completion of test
External Mechanical Integrity Test (MIT) and internal MIT*	Notification 30 days before and results within 30 days of completion of test
Pressure falloff testing	Notification 30 days before and results within 30 days of completion of test
Planned workover or well stimulation	Notification 30 days before and results within 30 days of completion of test
Monitoring well MITs	Notification 30 days before and results within 30 days of completion of test
Financial responsibility updates pursuant to H.2 and H.3(a) of this permit	Within 60 days of update

*Note: The reporting frequency for MIT will comply with TAC Title 16 Chapter 5.206(e)(1): “The operator of an anthropogenic CO₂ injection well must maintain and comply with the approved monitoring, sampling, and testing plan to verify that the geologic storage facility is operating as permitted and that the injected fluids are confined to the injection zone.”

All testing and monitoring frequencies as well as methodologies are included in the Testing and Monitoring Plan document of this permit.

The events that trigger an immediate emergency response should be reported within 24 hours, according to the 16 TAC 5.207(A) reporting requirements.

4.0. Operations

During operations, including start-up, normal operations and shut-in operations, OLCV will maintain injection rates and pressures listed in Table 1. During start-up operations, injection rates will gradually increase to the planned rate. Injection rates will be reduced gradually during a planned shut-in.

- 16 TAC 5.206(d)(2)(E): Continuous recording devices will monitor surface and downhole pressure, rate, volume and temperature. The injection rates will be controlled with variable control chokes.
- 16 TAC 5.206(d)(2)(B): Volume will be measured and recorded using an orifice flowmeter.
- 16 TAC 5.206(d)(2)(F): Automatic alarms and automatic shutoff systems will be installed and maintained. Successful function of the alarm system and shutoff system will be demonstrated prior to injection and once annually thereafter.

At all times, pressure will be maintained on the well to prevent the return of the injection fluid to the surface. The wellbore will be filled with a high-specific-gravity fluid during workovers to maintain a positive (downward) gradient and/or a plug shall be installed that can resist the pressure differential. A blowout preventer must be installed and kept in proper operational condition whenever the wellhead is removed to work on the well.

OLCV will cease injection according to the guidelines provided below:

- OLCV shall cease injection should it appear that the well is lacking mechanical integrity or that the injected CO₂ stream and/or associated pressure front may cause an endangerment to a USDW.
- OLCV must shut in the well by gradual reduction of the injection pressure and rate as outlined in the Summary of Operating Conditions document of this permit; or
- OLCV must immediately cease injection and shut in the well as outlined in the Emergency and Remedial Response Plan document of this permit.

F. TESTING AND MONITORING PLAN

TESTING AND MONITORING PLAN
16 TAC 5.203(j)

Brown Pelican CO₂ Sequestration Project

1.0 Facility Information and Plan Overview	2
2.0 Overall Strategy and Approach for Testing and Monitoring.....	2
2.1 Well Monitoring Network Design.....	7
2.2 Other Monitoring Techniques	15
2.3 Quality Assurance Procedures Summary	15
2.4 Reporting Procedures Summary.....	15
3.0 Carbon Dioxide Stream Analysis	15
3.1 Location and Frequency	15
3.2 Analytical Parameters.....	17
3.3 Sampling Methods.....	17
3.4 Laboratory to be Used, Chain of Custody, and Analysis Procedures.....	17
4.0 Continuous Recording of Operational Parameters	18
4.1 Monitoring Location and Frequency	18
4.2 Description of Methods and Justification.....	19
5.0 Corrosion Monitoring and Surface Leak Detection	21
5.1 Monitoring Location and Frequency	22
5.2 Description of Methods and Justification.....	23
6.0 Monitoring the Injection Zone.....	24
6.1 Monitoring Location and Frequency	24
6.2. Description of Methods and Justification.....	25
7.0 Monitoring the First Permeable Zone Above the Confining Zone.....	25
7.1 Monitoring Location and Frequency	25
7.2 Description of Methods and Justification.....	26
8.0 Monitoring the Near-Surface.....	26
8.1. USDW Sampling.....	27
8.2. Near-Surface Soil and Soil Gas Sampling.....	33
9.0 Internal and External Mechanical Integrity Testing	39
9.1 Testing Location and Frequency	39
9.2 Description of Methods and Justification.....	41
10.0 Pressure Fall-Off Testing	42
10.1 Testing Location and Frequency	42
10.2 Description of Methods and Justification.....	42
10.3 Interpretation of fall-off test results.....	43
11.0 Carbon Dioxide Plume and Pressure Front Tracking	44
11.1 Monitoring Location and Frequency	44
11.2 Description of Methods and Justification.....	45
12. Induced Seismicity Monitoring	51
12.1 Description of Methods and Justification.....	51

13.0 Reporting 55
14.0 References 56

1.0 Facility Information and Plan Overview

Facility name: Brown Pelican CO₂ Sequestration Project
BRP CCS1, CCS2 and CCS3 Wells

Facility contact: 

Well location: Penwell, Texas

BRP CCS1	31.76481926	-102.72891895
BRP CCS2	31.76994887	-102.73320589
BRP CCS3	31.76024766	-102.71013484

This Testing and Monitoring Plan describes how Oxy Low Carbon Ventures, LLC (OLCV), will monitor the Brown Pelican CO₂ Sequestration Project (BRP Project or Project) site pursuant to 16 TAC 5.203(j). Testing and monitoring data will be used to demonstrate that the UIC Class VI injector wells are operating as planned, the CO₂ plume and pressure front are behaving as predicted, and that there is no endangerment to Underground Sources of Drinking Water (USDW). In addition, the testing and monitoring data will be used to validate and adjust the geocellular and simulation models used to predict the distribution of the CO₂ within the storage zone to support Area of Review (AoR) re-evaluations and a non-endangerment demonstration at site closure.

Results of the testing and monitoring activities described below may trigger action according to the Emergency and Remedial Response Plan.

2.0 Overall Strategy and Approach for Testing and Monitoring

The Testing and Monitoring Plan was designed to monitor and mitigate the key risks identified for this Project that are described in the Emergency and Remedial Response Plan (included in Class VI SIP Permit No. 55294). During the Injection and Post-injection periods, those risks include the potential for: well integrity failure, leakage to USDW, natural disasters, induced seismicity, or critical surface impacts. The testing and monitoring methods included in this document are mitigations and controls to prevent CO₂ or brine leakage out of the Injection Zone that could endanger the USDWs, migrate to a different stratum, or create a risk for people or the environment.

In addition, the testing and monitoring program is tailored to track the migration of the CO₂ plume and development of the pressure front within the Injection Zone. Data will be collected prior to injection to establish a baseline. Data collected during the Injection and Post-injection periods from the testing and monitoring program will help to validate the simulation models and re-evaluate the AoR.

The testing and monitoring program includes controls and mitigations in the following categories:

1. Carbon dioxide stream analysis
2. Continuous recording of operational parameters: injection rate, volume, pressure, temperature, and internal mechanical integrity
3. Corrosion monitoring and leak detection
4. Above confining zone monitoring, including the first permeable zone above the confining zone, which is coincident with the lowermost USDW, and the near surface
5. Internal and external mechanical integrity testing
6. Pressure fall-off testing
7. Carbon dioxide plume and pressure front tracking
8. Surface Monitoring

The methodology and frequency of testing and monitoring methods is expected to change throughout the life of the Project. Pre-injection monitoring and testing will focus on establishing baselines and ensuring that the site is ready to receive injected CO₂. Injection period monitoring will be focused on collecting data to calibrate models and ensure containment of CO₂. Post-injection period monitoring and testing is designed to demonstrate CO₂ plume stabilization and ensure containment. The testing and monitoring plan will be reviewed at least once every five years and will be amended, if necessary, to ensure monitoring and storage performance is achieved and new technologies are appropriately incorporated.

Data obtained from the testing and monitoring plan will be used to inform operational decisions on the quantity and rate of CO₂ injected and potential containment actions. Data will be used to improve computational model forecasts. Data that is interpreted to be inconsistent with model predictions will trigger additional testing, monitoring, and evaluation.

A summary of the planned testing and monitoring methods that will be reported by the Project is listed in Table 1.

Table 1—Summary of testing and monitoring that will be reported by the Project.

Objective	Method	Pre-injection	During injection	Post-injection
16 TAC 5.203(j)(2)(A): CO ₂ injectate stream analysis	On-line gas analyzers and physical sampling for laboratory analyses	Collection of a sample for chemical and isotopic characterization prior to injection	Quarterly sampling for full compositional analyses; and isotopic analysis if capture process materially changes the source stream	N/A
16 TAC 5.203(j)(2)(B): Continuous recording of operational parameters in UIC Class VI injection wells: injection rate, volume, pressure, and temperature; and annulus pressure	P/T at surface and downhole; DTS fiber, and injection line flowmeter	Measurement and recording prior to injection	In UIC Class VI wells: Continuous measurement and recording	N/A
16 TAC 5.203(j)(2)(C): Quarterly corrosion monitoring in UIC Class VI injection wells	Corrosion coupons	N/A	In UIC Class VI wells: Quarterly coupon collection and analysis	N/A
16 TAC 5.203(h)(1)(B): Demonstrate internal mechanical integrity in UIC Class VI wells every five years	Pressure testing the tubing-casing annulus	Measurement prior to injection	In UIC Class VI wells: Annular pressure test once every five-year period, and after any workover that disturbs the seal between the tubing, packer, and casing	N/A
Demonstrate internal mechanical integrity in SLR and ACZ wells	Pressure testing the tubing-casing annulus	NA	In SLR and ACZ wells: Annular pressure test once every five-year period, and after any workover that disturbs the seal between the tubing, packer, and casing	In SLR and ACZ wells: Annular pressure test once every five-year period, and after any workover that disturbs the seal between the tubing, packer, and casing
16 TAC 5.203(h)(1)(D): Demonstrate external mechanical integrity once per year in UIC Class VI wells	DTS; or temperature or other log that provides equivalent or better information	Measurement prior to injection	In UIC Class VI wells: Annual DTS profile or other annual logging that provides external mechanical integrity information	N/A
Demonstrate external mechanical integrity in SLR and ACZ wells	DTS; or temperature or other log that provides equivalent or better information	NA	In SLR and ACZ wells: Once every five-year period, conduct DTS profile or other logging that provides external	In SLR and ACZ wells until plugging: Once every five-year period, conduct DTS profile or other logging that provides external

Objective	Method	Pre-injection	During injection	Post-injection
			mechanical integrity information	mechanical integrity information
16 TAC 5.203(j)(2)(G): Near well-bore formation properties testing (Pressure fall-off testing) in UIC Class VI wells	Pressure fall-off test	Measurement prior to injection	In UIC Class VI wells: Once during every five-year period until plugging	N/A
16 TAC 5.203 (j)(2)(D)(i); Injection Zone temperature, pH, conductivity, reservoir pressure, and static fluid level	P/T gauges and DTS in UIC Class VI wells; periodic logging to determine fluid level; periodic fluid sampling	Characterization prior to injection, including quarterly fluid and dissolved gas sampling for approximately one year in WW wells; Downhole and surface P/T in UIC Class VI injectors; pH, conductivity, pressure, and static fluid level collected during construction of UIC Class VI Injectors	In UIC Class VI wells: P/T gauge continuous monitoring In SLR2: annual fluid level logging and event-driven* fluid sampling for pH and conductivity, triggered by changes in P/T	In SLR2 until plugging: event-driven* fluid sampling for pH and conductivity, triggered by changes in P/T
16 TAC 5.203 (j)(2)(D)(i) and (ii); Monitoring for pressure changes above the top Confining Zone and for geochemistry changes in the lowermost USDW	P gauges in the ACZ1 and SLR1; fluid and dissolved gas sampling in USDW1	Characterization prior to injection, including pressure data in the ACZ1 and SLR1, and quarterly fluid and dissolved gas sampling for approximately one year in the USDW1	In ACZ1 and SLR1: Quarterly monitoring of pressure gauge data In USDW1: quarterly fluid and dissolved gas sampling in years 1-3 and annually starting in year 4; and, event-driven*, triggered by P/T data in SLR2 well	In ACZ1 and SLR1: Quarterly monitoring of pressure until plugging In USDW1: annual fluid and dissolved gas sampling for the first 10 years post injection pending an approved PISC plan; thereafter, event-driven* fluid and dissolved gas sampling, triggered by P/T data in SLR2 well
Soil and soil gas analysis (vadose zone; near surface)	Isotopic analysis and chemical evaluation	One soil sampling and analysis event; soil gas sampling and analysis prior to injection, including quarterly sampling for approximately one year prior to	Quarterly soil gas sampling in years 1-3, then annually starting in year 4 for subset of stations, and event-driven*, triggered by P/T data in SLR2 or USDW1 monitor wells and fluid sample results	Event-driven*, triggered by P/T data in SLR2 or USDW1

Objective	Method	Pre-injection	During injection	Post-injection
		commencement of injection		
16 TAC 5.203(j)(2)(E): Indirect geophysical monitoring of plume and pressure	2D VSP utilizing DAS or wireline conveyed geophones; 2D surface seismic; saturation logging; DInSAR and GPS	2D VSP and 2D surface acquisition prior to injection in UIC Class VI wells and in SLR2; baseline saturation logging; baseline DInSAR and GPS acquisition	In SLR2: Annual saturation logging; and 2D VSP at 5 or 10 years after commencement of CO ₂ injection In UIC Class VI Injection wells: 2D VSP at 1, 2, 5, and 10 years after commencement of CO ₂ injection 2D surface seismic at year 10 and approximately every five years thereafter Quarterly DInSAR and GPS	In SLR2: Annual saturation logging and 2D VSP once every approximately five years until plugging 2D surface seismic once every approximately five years until plume stabilization Annual DInSAR and GPS for first five years or until plume stabilization
Presence or absence of seismicity	Seismometers	Prior to injection	Continuous monitoring and recording	Continuous monitoring and recording until site closure

Notes:

*OLCV will monitor pressure and temperature data obtained from downhole and surface gauges and downhole temperature from DTS fiber daily and routinely evaluate long-term data trends to detect deviations from the reference temperature or pressure gradient. If persistent deviations in temperature or pressure are detected, OLCV will obtain reservoir fluid samples and analyze fluid and dissolved gas chemistry to determine the presence or absence of increased CO₂. In addition, fluid, and dissolved gas chemistry data from the lowermost USDW and soil gas chemistry from shallow soils will be monitored for trends to detect deviations from reference chemistry. If persistent and/or abrupt anomalies in chemistry are detected additional fluid or soil gas samples will be obtained to confirm the presence or absence of increased CO₂.

- DTS/DAS fiber installed in SLR1, SLR2, BRP CCS1, BRP CCS2, and BRP CCS3
- Pressure and Temperature (P/T) downhole gauges installed in BRP CCS1, BRP CCS2, BRP CCS3, WW1, WW2, WW3, WW4, and SLR2
- Pressure and Temperature (P/T) surface gauges installed at BRP CCS1, BRP CCS2, BRP CCS3, and SLR2
- Pressure (P) surface gauges installed at SLR1, ACZ1, WW1, WW2, WW3, and WW4
- Acronyms:
 - DInSAR = Differential Interferometric Synthetic Aperture Radar
 - DAS = Distributed Acoustic Sensing
 - DTS = Distributed Temperature Sensing
 - GPS = Global Positioning System
 - MIT = Mechanical Integrity Test
 - PISC = Post-Injection Site Care period
 - P/T = Pressure and Temperature
 - UIC = Underground Injection Control
 - USDW = Underground Source of Drinking Water
 - VSP = Vertical Seismic Profile

2.1 Well Monitoring Network Design

Multiple testing and monitoring objectives described in Table 1 will be accomplished by evaluating data from monitoring wells (Table 2). These wells will provide direct measurements to compliment indirect measurement methods for monitoring the AoR. In addition, data from monitoring wells will be used to characterize fluid chemistry and isotopic composition throughout the stratigraphic column. A summary of data by well type is shown in Table 3.

OLVC installed a Single Reservoir-level (SLR) well, the SLR2, as a dedicated monitor for the Injection Zone. OLCV installed the USDW1 well as a dedicated monitor for the lowermost Underground Source of Drinking Water Aquifer (USDW), the Dockum Group. An additional Injection Zone monitoring well, SLR3, may be proposed pending data collected during operations and updates to the AoR after start-up of CO₂ injection operations. The need for additional monitoring wells will be evaluated as needed, and at least annually during the injection period and until plume stabilization.

In addition to the SLR2 well, the Injection Zone will be directly monitored with data collected in four brine withdrawal wells (WW). The WW wells extract brine to manage pressure in the Injection Zone. The brine is transported via pipeline for use in Oxy or third-party operations or transported to the location of planned Class I disposal wells. The CO₂ injectate plume is not expected to reach the WW1, WW3 and WW4. If the CO₂ plume does reach these WW wells, they will be shut in. The CO₂ injectate plume is expected to reach WW2. When the CO₂ plume in the Holt sub-zone reaches WW2, the well will be plugged above the Holt and continue to produce brine from the upper portion of the Lower San Andres. The CO₂ plume in the upper part of the Lower San Andres (G4 and G1 sub-zones) is not expected to reach the WW2.

Note that OLCV previously intended to utilize the Shoe Bar 1 and Shoe Bar 1AZ to monitor the first permeable zone above the Upper Confining Zone, however OLCV now plans to use these wells to monitor the Upper Confining Zone. OLCV changed the monitoring purpose for these wells after reviewing wireline data acquired during construction of the brine withdrawal wells in Spring 2024 that indicates the absence of permeable zones above the Upper Confining Zone and below the lowermost USDW. Therefore, the Dockum group is both the lowermost USDW and the first permeable zone above the Upper Confining Zone. The USDW1 well will be used to monitor geochemistry in the Dockum group for 16 TAC 5.203(j)(2)(D)(ii).

Table 2—Wells used for monitoring

API or State well number	Project Well Name	Regulatory Well Name	Purpose	Drill Date	Anticipated Plug Date	Latitude (NAD 27)	Longitude (NAD 27)
4213544065	SLR2	Shoe Bar Ranch 2SL	Injection Zone monitor	2025	~20 years post Injection Period	31.74657954	-102.72586378

4213543920	Shoe Bar 1 or SLR1	Shoe Bar Ranch 1	Stratigraphic test, Confining Zone monitor	2023	2025 ¹ and ~10 years post Injection Period	31.76343592	-102.70349808
4213543977	Shoe Bar 1AZ or ACZ1	Shoe Bar Ranch 1AZ	Stratigraphic test, Confining Zone monitor	2023	2025 ¹ and ~10 years post Injection Period	31.76448867	-102.73053251
657173	USDW1	ShoeBar Monitor Well #1	USDW monitor	2024	~20 years post Injection Period	31.76411900	-102.7316750
4213544035	WW1	Shoe Bar Ranch 1WW	Brine withdrawal, Injection Zone monitor	2024	End of Injection Period	31.76289537	-102.69592320
4213544036	WW2	Shoe Bar Ranch 2WW	Brine withdrawal, Injection Zone monitor	2024	After ~seven years of injection ² ; End of Injection Period	31.78419970	-102.72758691
4213544037	WW3	Shoe Bar Ranch 3WW	Brine withdrawal, Injection Zone monitor	2024	End of Injection Period	31.75008559	-102.71022070
4213544034	WW4	Shoe Bar Ranch 4WW	Brine withdrawal, Injection Zone monitor	2024	End of Injection Period	31.76384466	-102.75395043
NA	SLR3 ³	Shoe Bar Ranch 3SL	Injection Zone monitor	~2030; ~5 years after commencement of CO ₂ injection	~10 years post Injection Period	31.78023685	-102.7418093

¹conversion from stratigraphic test well to monitor well

²plugging of Holt subzone

³OLCV will determine the need for SLR3 following review of operational data and AoR review in approximately 2030

Table 3—Summary of monitoring by well type and Project stage.

Well type	Objective	Method	Monitoring Pre-Injection	Monitoring During Injection	Monitoring Post-Injection
SLR2; Injection Zone monitoring	Direct measurement of fluids for pH and conductivity	Fluid and dissolved gas sampling via wireline or U-tube	Baseline sampling	Event-driven*	Event-driven*, until plugging
	Fluid level logging	Echometer or equivalent log	Baseline logging	Annually	Event-driven*, until plugging

	Indirect monitoring of CO ₂ concentration	Pulsed Neutron Log (PNL) or Reservoir Saturation Tool (RST) log	Baseline logging	Annually	Annually until plugging
	Indirect geophysical monitoring of plume and pressure	2D VSP	Baseline survey	Years 5 or 10 post commencement of CO ₂ injection	Once every approximately five-year period until plugging
SLR1 and ACZ1; Upper Confining Zone monitoring	Direct monitoring of pressure	Surface pressure gauges	Prior to injection	Quarterly monitoring of P gauge data	Quarterly monitoring of P gauge data until plugging
USDW1; Lowermost USDW monitoring	Geochemical monitoring of fluids and dissolved gasses	Fluid and dissolved gas sampling using a bladder pump	Baseline sampling	Quarterly sampling in years 1-3, annually starting in year 4; and event-driven*	Annually for the first 10 years post injection pending an approved PISC plan; and event-driven*, until plugging
WW1, WW2, WW3, WW4; Injection Zone monitoring	Geochemical and isotopic monitoring to detect CO ₂	Fluid sampling at the wellhead	Baseline sampling	Event-driven*	Event-driven*, until plugging

*OLCV will monitor pressure and temperature data obtained from downhole gauges and/or DTS fiber daily, and also routinely evaluate long-term data trends to detect deviations from the reference temperature or pressure gradient. If persistent deviations in temperature or pressure are detected, OLCV will obtain reservoir fluid samples and analyze fluid and dissolved gas chemistry to determine the presence or absence of increased CO₂. In addition, fluid, and dissolved gas chemistry data from the lowermost USDW and soil gas chemistry from shallow soils will be monitored for trends to detect deviations from reference chemistry. If persistent and/or abrupt anomalies in chemistry are detected additional fluid or soil gas samples will be obtained to confirm the presence or absence of increased CO₂.

2.1.1 Injection Zone monitoring wells

OLCV proposes a phased drilling approach to allow for incorporation of operational data to the monitoring plan. The data obtained during early CO₂ injection may result in adjusting future well locations or timing of drilling.

- The Shoe Bar 1 well is a stratigraphic test well that was completed in February 2023. This well is located near the BRP CCS3 well and is within the maximum extent of the modelled AoR. For monitoring purposes, the well will be referred to as SLR1. The Shoe Bar 1 well was not constructed with Cr25 casing; it was plugged above the Injection Zone in February 2025, prior to the commencement of CO₂ injection. The well contains Distributed Temperature Sensing and Distributed Acoustic Sensing (DTS/DAS) fiber that may be used during Vertical Seismic Profile (VSP) seismic acquisition and for monitoring temperature

above the Confining Zone. A 2D VSP may be collected in the future to constrain the position of the CO₂ plume and critical pressure front.

- The SLR2 well was drilled in 2024, prior to the commencement of CO₂ injection operations. It is located within the extent of the CO₂ plume created after approximately seven years of injection. Pressure and temperature will be monitored using downhole gauges and temperature will be measured using DTS fiber. Fluid samples from the Injection Zone may be collected, if pressure or temperature changes indicate a change in brine composition consistent with arrival of CO₂. OLCV acquired a baseline 2D VSP in the SLR2 in early 2025, and 2D VSP acquisition will be repeated at 5 or 10 years after the commencement of CO₂ injection at the Project site.
- After commencement of CO₂ injection operations, OLCV will evaluate the need for a SLR3 well. If drilled, the well could provide direct information on CO₂ presence.

The SLR2 well location was selected based on potential leakage pathway scenarios, and on the computationally simulated plume and critical pressure front. The modelled CO₂ plume and pressure front extends semi-radially from the BRP CCS1, BRP CCS2 and BRP CCS3 wells. The SLR2 well was placed to detect movement of the plume and pressure front.

The SLR2 well is completed with tubing and packer, isolates the Upper San Andres and Grayburg formations (Upper Confining Zone), and has open perforations in the Lower San Andres (Injection Zone) to allow direct measurements in the Injection Zone (Figure 1). Pressure and temperature gauges are tubing-deployed to track changes in reservoir conditions during the Injection and Post-injection periods. It is possible to obtain fluid samples from the SLR2 well to conduct geochemical analyses.

The figure below illustrates the design of the SLR2 well. A U-tube system for retrieving fluid samples is installed at SLR2. OLCV will evaluate whether this technology is appropriate for potential future wells. A U-tube system allows for cost-effective sampling of fluids and dissolved gases from the Injection Zone. However, there are few examples of this technology deployed to active projects in the field, therefore little is known about the expected life of the equipment at field conditions. Furthermore, existing U-tube systems are not typically deployed to reservoirs where H₂S is present, like those at the Project site.

U-tubes are not contemplated for brine withdrawal wells, because the U-tube system would interfere with operation of the electrical submersible pump (ESP) installed to produce brine. U-tubes are not contemplated for wells monitoring the Upper Confining Zone (SLR1 or ACZ1) because frequent monitoring of fluid chemistry and dissolved gas is not planned for these wells, as no Injection Zone fluids are expected to reach these wells. A U-tube is not planned for the USDW1 well, because the well is designed with a bladder pump to efficiently sample fluids and dissolved gases.

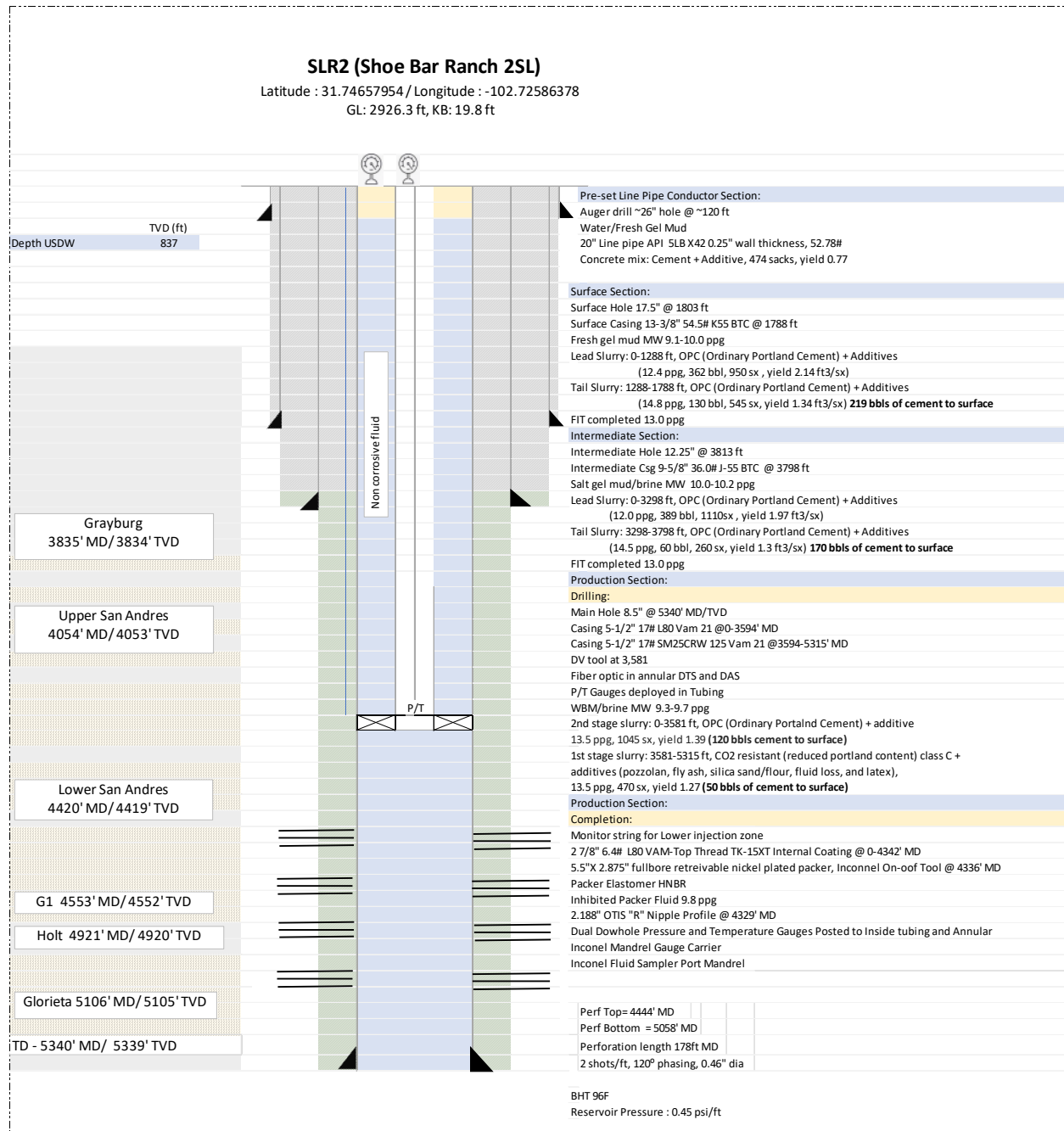

Figure 1—SLR2 schematic

2.1.2 Shoe Bar 1AZ well

The Project initially intended to convert the Shoe Bar 1AZ to be a monitoring well for the Yates formation, which was interpreted on log data from the Shoe Bar 1 and Shoe Bar 1AZ to be the first permeable zone above the Upper Confining Zone. However, wireline testing during construction of the WW1, WW2, WW3, and WW4 shows the absence of permeable zones between the Upper Confining Zone and the lowermost USDW. The Dockum group is defined as the lowermost

Plan revision number: 7
 Plan revision date: 05/25/2026

USDW. Therefore, the Dockum group is both the lowermost USDW and the first permeable zone above the Upper Confining Zone. See Section 5 of Appendix A to the AoR document for a detailed description of testing and results.

In spring 2025, OLCV re-entered the Shoe Bar 1AZ and plugged below the Upper Confining Zone. This well will be used to monitor integrity of the Upper Confining Zone through periodic saturation logging and surface pressure monitoring.

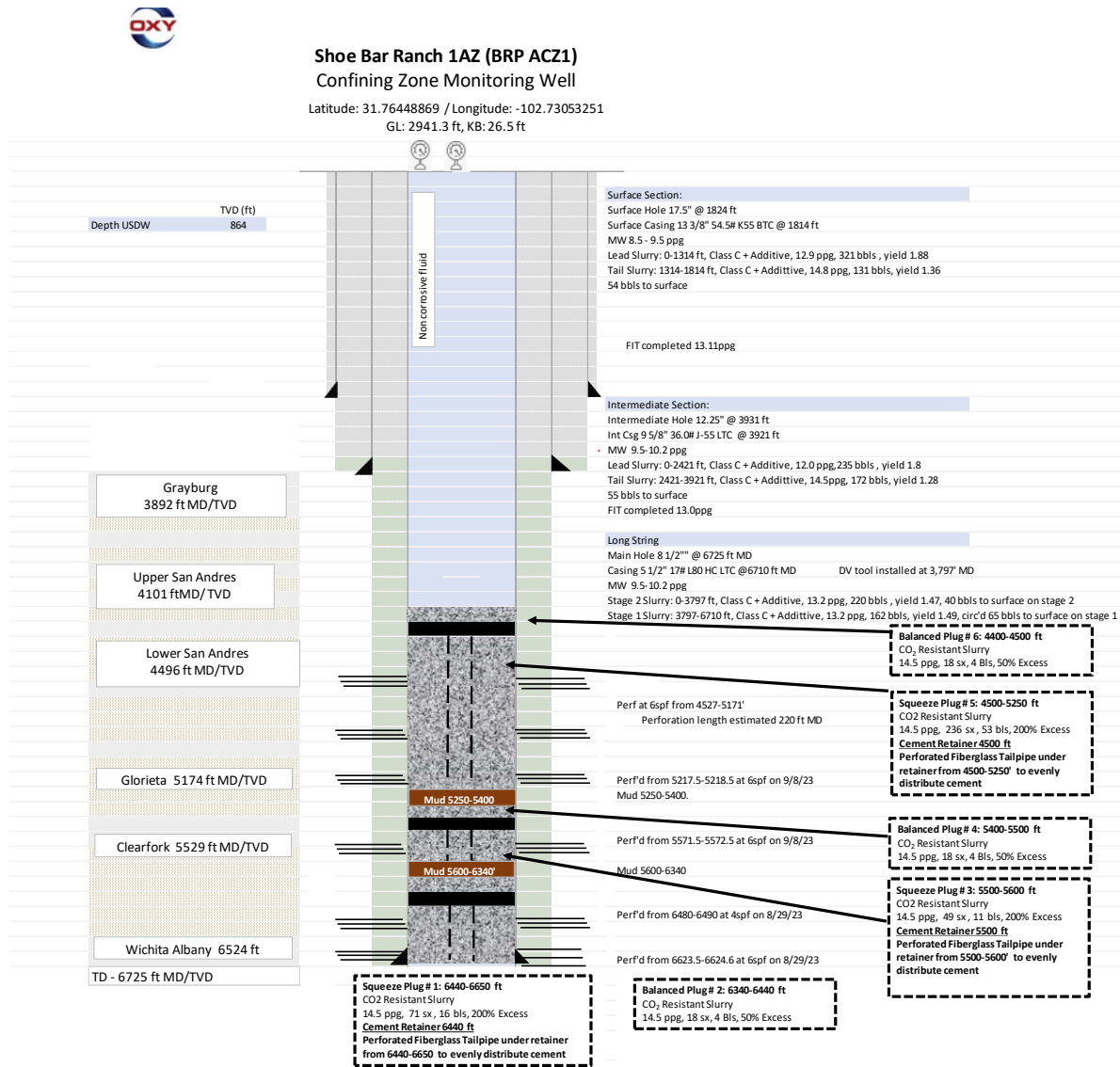

Figure 2—Shoe Bar 1AZ schematic after plugging below the Upper Confining Zone

Plan revision number: 7

Plan revision date: 05/25/2026

2.1.3 USDW Monitoring Well

A USDW-level well was drilled and completed in 2024 in the lower portion of the Dockum group, which is the lowermost USDW. This well will be used to collect baseline geochemical and isotopic information about the USDW prior to the commencement of CO₂ injection and will be used to monitor groundwater geochemistry and dissolved gas during the Injection Period of the Project.

The USDW monitoring well is located close to the BRP CCS1 and BRP CCS2 wells and will be used to monitor the effects of reservoir pressurization and validate the sealing capacity of the Upper Confining Zone.

No other existing USDW wells are located within the expected AoR of the Project. Because the modelled AoR is small, ~2.5 miles in diameter, OLCV believes that one USDW well will provide sufficient monitoring data.

The figure below shows the wellbore diagram for the USDW1 well.

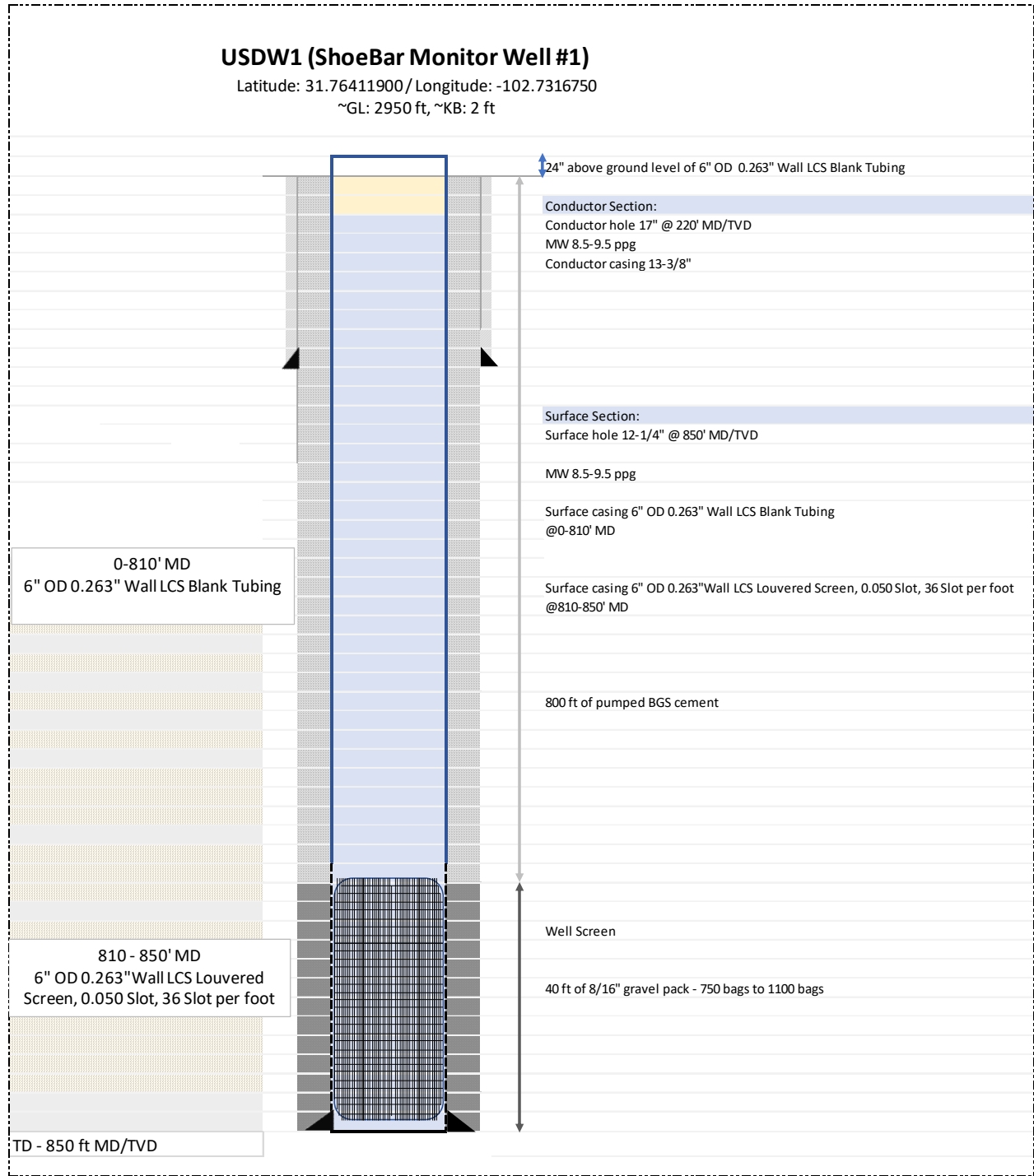

Figure 3—USDW Monitoring well

2.2 Other Monitoring Techniques

In addition to utilizing a well-based network to monitor pressure, temperature, and fluid and dissolved gas chemistry of the subsurface, OLCV will also utilize surface and near-surface methods to monitor CO₂ containment. Additional details on geophysical monitoring methods are described in Sections 11 and 12 of this document. Near-surface soil and soil gas monitoring are described in Section 8.2.

2.3 Quality Assurance Procedures Summary

A Quality Assurance and Surveillance Plan (QASP) for testing and monitoring activities, is provided as a separate document.

2.4 Reporting Procedures Summary

OLCV will report the results of all testing and monitoring activities to the Railroad Commission of Texas in compliance with the requirements under 16 TAC 5.207.

3.0 Carbon Dioxide Stream Analysis

OLCV will analyze the CO₂ stream prior to injection to yield data representative of its chemical and physical characteristics [16 TAC 203(j)(2)(A)], and OLCV will analyze the CO₂ injectate stream during the operation period to yield data representative of its chemical and physical characteristics [16 TAC 207(a)(2)(C)(ii)].

The source of the CO₂ for the Project is a Direct Air Capture (DAC) facility that is located near the proposed CO₂ sequestration site. The DAC facility, called Stratos, will extract CO₂ from air, and the produced stream will be primarily composed of CO₂, O₂ and H₂O (Table 4).

3.1 Location and Frequency

The CO₂ injectate stream will be continuously monitored for CO₂, O₂, and H₂O. Continuous monitoring of CO₂ is critical to achieving the goals of the Project. O₂ and H₂O are important to continuously monitor because limiting these components is critical to prevent corrosion of wellbore materials and piping. O₂ will be monitored by a galvanic fuel cell, and H₂O will be monitored by an aluminum oxide sensor. CO₂ will be monitored with an on-line chromatograph.

On-line analyzers for CO₂, O₂, and H₂O are located at the Stratos facility and are alarmed to alert Stratos and BRP analysts when values approach and exceed the specified values in Table 4. In the event that on-line analyzer data indicates that the injectate stream may be off-specification, the on-line analyzer data will be closely reviewed, and the analyzers may be physically inspected. Based on operational experience, minor system upsets are typically resolved within 60 minutes and the

composition is restored to the specification. If the injectate stream is not restored to the specification within 60 minutes, OLCV will cease to accept the injectate stream. Acceptance of the injectate stream will resume when the stream is restored to the specification. This process ensures that the CO₂ injectate stream entering the UIC Class VI injection wells is consistent with the expected composition.

Gas phase samples of the CO₂ injectate stream will be collected, at least once per quarter, at a port directly downstream of the custody transfer meter used to measure the mass of CO₂ delivered to the BRP Project. Table 4 shows the list of injectate stream components that will be analyzed in a laboratory by a qualified third-party contractor.

The isotopic composition of the CO₂ injectate stream will be sampled prior to injection. These data will be used to determine a baseline and to complement the gas, soil, and water characterization methods. Samples for isotopic compositional baseline analysis will be sent to a commercial laboratory for evaluation.

Continuous on-line monitoring of the CO₂ injectate stream, coupled with routine laboratory analysis will provide appropriate data resolution and limit corrosivity or other adverse downhole impacts. See Table 5 for a summary of injectate monitoring plans.

Table 4—CO₂ injectate stream specification.

Component	Specification
CO ₂ content	>95 mol% (>96.5 mass%)
Water	<30 lbm/MMscf
Nitrogen	<4 mol%
Sulphur	<35 ppm by weight
Oxygen	<5 mol%
Glycol	<0.3 gal/MMscf
Carbon Monoxide	<4,250 ppm by weight
NO _x	<6 ppm by weight
SO _x	<1 ppm by weight
Particulates (CaCO ₃)	<1 ppm by weight
Argon	<1 mol%
Surface pressure	>1,600 psig
Surface temperature	>65°F and <120°F
Isotopes	δ ¹³ C and ¹⁴ C of CO ₂

Table 5—CO₂ injectate stream frequency of reporting.

Method	Pre-Injection	Injection	Post-Injection
Samples obtained from a sample port in the pipeline upstream of the UIC Class VI injector wells for purposes of geochemical characterization	Sample collection prior to injection	Quarterly; or event-driven* if the DAC process materially changes	N/A
Samples obtained from a port in the pipeline upstream of the UIC Class VI injector wells for purposes of isotopic analysis	Sample collection prior to injection	Event-driven* if the DAC process materially changes	NA

*Event-driven = changes in the DAC process may arise from facility upgrades or after facility shut-in periods.

3.2 Analytical Parameters

The Stratos facility has developed a standard CO₂ injectate stream specification, as shown in Table 4. OLCV will notify the RRC before any anticipated change in CO₂ injectate stream composition. In addition, any changes to the physical, chemical, and other relevant characteristics of the CO₂ injectate stream, or a demonstration that these characteristics have not changed since the previous reporting period, will be described in a semi-annual report submitted to the RRC.

3.3 Sampling Methods

Sample collection for laboratory analysis will follow the procedure outlined in ASTM D1945, GPA-2177-20 or other industry-accepted methods to ensure that the sample is representative of the injected CO₂ stream. A sampling station is installed with the ability to purge and collect samples into a container that will be sealed and sent to the third-party authorized laboratory. A third-party contractor will be responsible for collecting the samples, transporting the samples to a laboratory, and for sample analysis.

3.4 Laboratory to be Used, Chain of Custody, and Analysis Procedures

The CO₂ injectate stream samples will be analyzed in accordance with GPA-2177-20 or other industry-accepted method by a third-party laboratory. Sampling procedures will follow contractor protocols to ensure the sample is representative of the CO₂ injectate stream. Samples will be processed, packaged, and shipped to the contracted laboratory, following the process described in the QASP that is part of this application.

4.0 Continuous Recording of Operational Parameters

OLCV installed continuous recording devices to monitor injection pressure, rate, and volume; the pressure on the annulus between the tubing and the long string casing; and the temperature of the CO₂ stream, as required in 16 TAC 5.203(j)(2)(B), 5.203(h)(1)(C), and 5.206(d)(2)(E).

4.1 Monitoring Location and Frequency

CO₂ injection operations will be continuously monitored and controlled by OLCV and/or Oxy staff utilizing a process control system. The system will continuously monitor, control, record, and alarm for critical system parameters of pressure, temperature, and injection flow rate. The system will initiate a shutdown if specified control parameters deviate from the intended operating range and will allow for remote shutdown under emergency conditions. Trend analysis will aid in evaluating the performance (e.g., drift) of the instruments, indicating the need for maintenance or calibration.

Monitoring and metering locations and frequencies for UIC Class VI injectors are summarized in Table 6 below.

Table 6—Continuous monitoring methods and frequency for UIC Class VI injectors.

Objective	Method	Minimum sampling frequency	Minimum recording frequency
Injection pressure and temperature at surface	Surface gauges installed on injection flowline near wellheads	One second	30 seconds
Injection rate and volume	Mass flow meter on injection flowline near wellheads	One minute	One hour
Injection pressure and temperature downhole	Downhole tubing-deployed gauge above packer ported to tubing above packer	10 seconds	30 seconds
	DTS fiber (temperature)	15 minutes	30 minutes
Pressure on the annulus between the tubing and long string casing	Downhole tubing-deployed gauges ported to annulus above packer	10 seconds	30 seconds
Annular pressure at surface	Pressure gauge installed in wellhead	One second	30 seconds
Annulus volume	Continuous pressure monitoring between tubing and production casing, and continuous monitoring of pressure at surface to confirm absence of leakage.	10 seconds pressure gauge;	30 seconds on pressure

	Direct fluid level measurements may also be obtained, as triggered by pressure data.	fluid level as needed	gauge, fluid level as needed
--	--	-----------------------	------------------------------

4.2 Description of Methods and Justification

4.2.1 Pressure and Temperature Monitoring

OLCV will monitor and measure injection pressure and temperature (P/T) three ways in the UIC Class VI injector wells: downhole gauges, DTS (temperature only), and surface gauges. One P/T gauge is installed downhole as part of the completion and ported into the tubing to continuously measure injection P/T. The downhole sensor will be the point of compliance for maintaining injection pressure below 90% of formation fracture pressure.

A second P/T gauge is installed on the outside of the tubing string above the packer to measure pressure continuously in the annular space above the packer and identify any potential loss of mechanical integrity.

At the surface, electronic pressure gauges and temperature sensors will be used to continuously monitor the pressure and temperature of the annulus between the tubing and long string casing. Gauges and sensors will be connected to the automation system to provide continuous data analysis as well as alarms for malfunctioning events when the values deviate from the intended operating range.

If the downhole gauges stop working between scheduled maintenance events, then the surface pressure limitation approved for this permit will be used as a backup until the downhole gauges are repaired or replaced. For calibration purposes, in lieu of removing the injection tubing, the accuracy of the downhole gauges will be demonstrated by using a second pressure gauge with current certified calibration lowered into the well at the same depth as the permanent downhole gauge.

In addition to gauges, DTS fiber optic cable is attached along the side of the casing and to an interrogator on the surface, which will provide a distributed temperature profile. This system will record temperature continuously to aid in monitoring the CO₂ behavior and confirm mechanical integrity in the well.

4.2.2 Injection Rate and Volume Monitoring

The mass flow rate of CO₂ injected into the UIC Class VI wells will be measured using flowmeter skids containing Coriolis meters. The skids are located on the CO₂ injection flowlines near the wellheads, shown as FE-100 in Figure 4. Piping and valving are configured to permit flowmeter calibration. A redundant pressure control valve is installed to allow for continuous injection during routine maintenance. The flow transmitter is connected to a remote terminal unit (RTU) on the flowmeter skid.

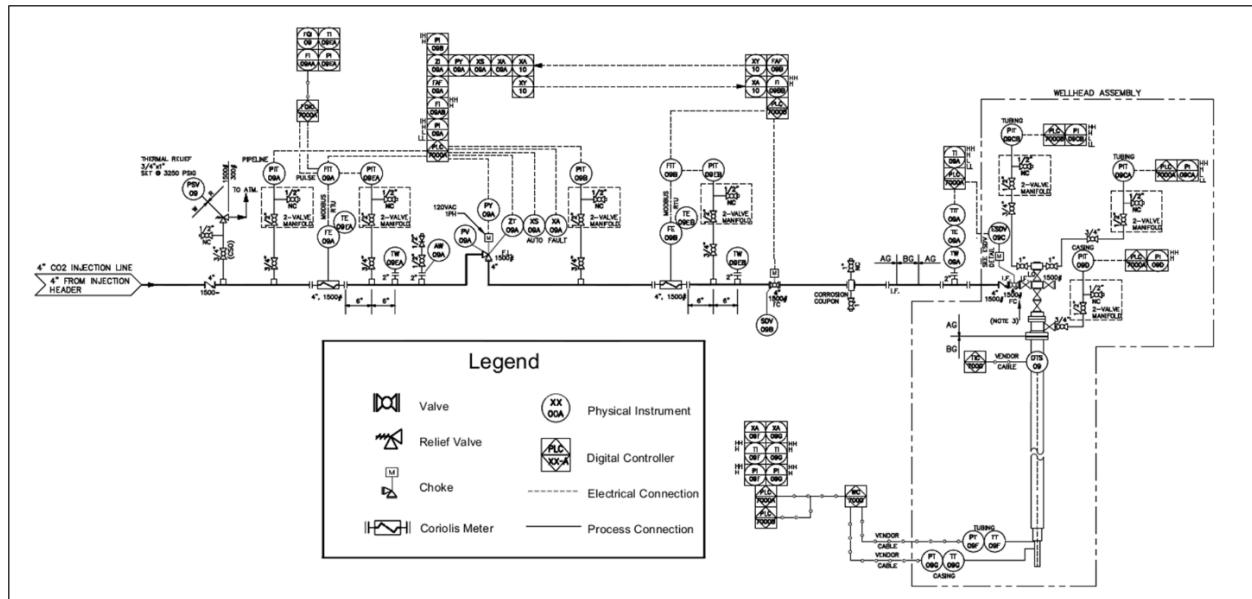

Figure 4—Representative example of wellhead process and instrumentation diagram.

The process control system will limit the flowline pressure to 2,800 psi to protect the surface equipment. Each well has different limits on wellhead pressure and process control will limit pressure to protect the Injection Zone.

4.2.3. Packer Fluid / Annulus Volume Monitoring

The initial volume of packer fluid to fill the casing will be measured prior to the commencement of CO₂ injection operations. Annular pressure will be kept between 100 and 400 psi on surface, and pressure data obtained from surface gauges and downhole gauges will be used to confirm the absence of unexpected changes in annulus volume. In addition, if there are changes in pressure, OLCV will conduct fluid level measurements to further confirm annulus fluid volume. This methodology will allow the operator to confirm the variation in annular fluid due to temperature changes v. potential mechanical integrity issues.

4.2.4. Justification of Continuous Monitoring Methods and Backup Options

Multiple measurements of P/T will be collected in the UIC Class VI wells to provide confidence in the data. Downhole and surface gauges are routinely used in well operations and have historically performed to expectation over the operational life of the well. DTS technology is newer in operational deployment, thus its long-term performance history is less constrained. If DTS fails before the end of the monitoring period, gauges will be utilized to meet monitoring requirements.

In the event anomalous measurements are obtained from the temperature gauges or from DTS fiber, the gauges and wellhead will be manually inspected. Maintenance or repair operations on the instruments will commence, if required. If anomalous measurements are detected, OLCV will conduct further investigation. OLCV will conduct appropriate repairs or adjustments and re-collect data, if needed.

Plan revision number: 7

Plan revision date: 05/25/2026

The injection rate and volume metering protocols to be used at the BRP Project follow the prevailing industry standard(s) for custody transfer as currently promulgated by the American Petroleum Institute (API) and the American Gas Association (AGA). This approach is consistent with EPA GHGRP's Subpart RR, section 98.444(e)(3). These meters will be maintained and calibrated routinely, operated continually, and will feed data directly to the centralized data collection systems. The meters meet the industry standard for custody transfer meter accuracy and calibration frequency.

5.0 Corrosion Monitoring and Surface Leak Detection

To meet the requirements of 16 TAC 5.203(j)(2)(C), OLCV will monitor well materials during the operation period for loss of mass, thickness, cracking, pitting, and other signs of corrosion to ensure that the well components meet the minimum standards for material strength and performance.

Materials (Table 7) have been selected to mitigate and inhibit corrosion. The suitability of the materials has been determined with published performance data from materials suppliers. A summary of materials is listed below. OLCV will monitor via coupons the materials used in the well construction and that will be exposed to the CO₂ injectate stream and reservoir fluids.

Table 7—List of equipment with construction materials in the pipeline, UIC Class VI injectors, Injection Zone monitoring wells and brine withdrawal wells.

Equipment	Construction Material
Pipeline	Carbon steel
Long string casing <i>above Injection Zone</i> in UIC Class VI wells, Injection Zone monitoring, and brine withdrawal wells	Carbon steel L80 Steel, Super Duplex 2507 SS, #17, 80kpsi
Long string casing <i>in Injection Zone</i> in UIC Class VI injector wells	Super Duplex 2507 SS, #17, 80kpsi
Long string casing <i>in Injection Zone</i> for Injection Zone monitoring wells and brine withdrawal wells	Carbon Steel L80 Steel, Super Duplex 2507 SS, #17, 80kpsi.
Tubing <i>above packer</i> in UIC Class VI injector wells	Coated TK 805 carbon steel L80
Tubing for Injection Zone monitoring wells and brine withdrawal wells	Coated TK 805 carbon steel L80
Wellhead for UIC Class VI injector wells, Injection Zone monitoring wells, and brine withdrawal wells	Alloy Steel DD specification
Injection tree and tubing hanger for UIC Class VI injector wells	Sour service HH specifications
Packers for UIC Class VI injector wells and Injection Zone monitoring wells and brine withdrawal wells	Nickel-plated / HNBR (RGD) elastomers

5.1 Monitoring Location and Frequency

Corrosion monitoring of the UIC Class VI wells will be conducted in a surface monitoring coupon holder located near the wellhead. To measure corrosion, coupons or probes composed of well materials will be inserted at the coupon holder, and those coupons or probes will be exposed to fluids being injected. Coupons/probes will be collected and sent to a third-party laboratory for analysis in accordance with NACE Standard SP-0775-2018-SG on a quarterly basis during the Injection Period and until wells are plugged in the Post-injection Period. Note that CO₂ originating from the injectate stream is not expected to be encountered in the brine withdrawal wells or in Confining Zone monitor wells.

In addition to coupons, OLCV may conduct visual inspection of the facilities, utilize optical gas imaging cameras (OGI), and evaluate data from DTS to monitor for potential leakage that could result from corrosion.

In the event that OLCV collects data that are consistent with possible corrosion, OLCV will re-conduct a visual inspection of the facilities, conduct a physical inspection using nondestructive techniques, and/or re-collect data from coupons or OGI. If corrosion is confirmed, OLCV will assess equipment fitness for service and take appropriate remediation actions.

Casing inspection logging may be conducted during planned well maintenance operations to evaluate downhole conditions and confirm absence of corrosion.

Table 8 provides a summary of corrosion monitoring reported by the Project.

Table 8—Corrosion monitoring reported by the Project.

Objective	Method	Pre-Injection	Injection	Post-Injection
Identify material corrosion in flowline and wellbore	Corrosion coupons	N/A	Quarterly	N/A

5.2 Description of Methods and Justification

5.2.1 Corrosion Coupons

Samples of UIC Class VI injector well materials (coupons) will be exposed to the injected CO₂ stream and monitored for signs of corrosion to verify that the well components meet the minimum standards for material strength and performance and to identify well maintenance needs. The coupon location will be safe and easily accessible for the vendor to retrieve. Coupons will be analyzed by a third party in accordance with NACE Standard SP-0775-2018-SG to determine and document corrosion wear rates based on mass loss. A summary of coupon parameters is shown in Table 9.

Table 9—Summary of analytical parameters for corrosion coupons.

Parameters	Analytical Method	Resolution Instruments	Precisions/Std Dev
Mass	NACE SP0775-2018-SC	0.05 mg	2%
Thickness	NACE SP0775-2018-SC	0.01 mm	± 0.05 mm

NACE SP0775-2018-SC: Preparation, Installation, Analysis, and Interpretation of Corrosion Coupons in Oilfield Operations

Coupon data will be evaluated by OLCV engineers to confirm that well components meet the standards for material strength and performance. Appropriate corrective action will be taken, if needed, to restore the well components to meet operational standards.

5.2.2. Casing Inspection Logs

OLCV may perform casing inspection logging (CIL) during planned well maintenance. Between planned maintenance events, OLCV may conduct a CIL, if corrosion coupon data indicates potential loss of material strength or performance inconsistent with operating standards.

5.2.3. Surface detection methods

Field personnel will visit the Project location on a routine, e.g., weekly, basis to make observations of surface equipment, identify potential leaks, and verify that equipment is operating within design limits. Field personnel will be provided with handheld equipment to identify the presence of H₂S as part of the safety requirements for the site.

Additional, quarterly, optical analysis using OGI cameras may be performed during the injection period. OGI cameras are highly specialized cameras that use infrared imaging to spot invisible gases as they escape. These cameras will be used during the inspection of facilities, pipelines, and well locations.

6.0 Monitoring the Injection Zone

OLCV will conduct periodic sampling of the fluid temperature, pH, conductivity, reservoir pressure, and static fluid level of the Injection Zone [16 TAC 5.203(j)(2)(D)(i)].

6.1 Monitoring Location and Frequency

The Lower San Andres Injection Zone will be directly monitored using the UIC Class VI injection wells and the SLR2 monitoring well. The SLR2 was drilled prior to the commencement of CO₂ injection and is located within the maximum extent of the pressure front resulting from CO₂ injection. The Injection Zone geochemistry and pressure may also be directly monitored by WW1, WW2, WW3, WW4.

Table 10—Injection Zone monitoring reported by the Project.

Objective	Method	Frequency pre-injection	Frequency during injection	Frequency post-injection
Pressure and temperature monitoring downhole	Downhole P/T gauge ported to tubing and ported to annulus in UIC Class VI injector wells	Prior to injection	Continuously, 10 second sampling and 5-minute recording frequency	Continuously until UIC Class VI wells are plugged
pH and conductivity	Fluid and sampling and analysis in SLR2	During construction of SLR2 well and WWs and prior to CO ₂ injection to establish characterization	Event-driven*, triggered by P/T data	Event-driven*, triggered by P/T data
Fluid level	Logging in SLR2	During well construction	Annual	Event-driven*, until plugging

Plan revision number: 7

Plan revision date: 05/25/2026

*OLCV will monitor pressure and temperature data obtained from downhole and surface gauges and temperature data from DTS fiber daily and routinely evaluate long-term data trends to detect deviations from the reference temperature or pressure gradient. If persistent deviations in temperature or pressure are detected, OLCV will obtain reservoir fluid samples and analyze fluid and dissolved gas chemistry to determine the presence or absence of increased CO₂. Saturation logging may also be conducted to further support or refute the presence of increased CO₂.

6.2. Description of Methods and Justification

Pressure and temperature downhole gauges and surface pressure gauges will be installed in the SLR2. See Section 1.4.7 in QASP for description of gauges.

Fluid and dissolved gas samples were collected while drilling the SLR1, ACZ1, WW1, WW2, WW3, WW4, BRP CCS1, BRP CCS2, BRP CCS3, and SLR2 wells. Additional fluid and dissolved gas samples were conducted to constitute a baseline. These samples were analyzed for their geochemical composition and isotopic characterization. If anomalous pressure and temperature changes are observed during injection or post-injection, fluid samples and/or dissolved gas samples will be obtained for geochemical and isotopic analyses and comparison with pre-injection samples.

7.0 Monitoring the First Permeable Zone Above the Confining Zone

The first permeable zone above the Confining Zone is the Santa Rosa formation, which is the lowermost member of the Dockum group. It will be monitored with the USDW1 well, a dedicated monitoring well that is located close to BRP CCS1 and BRP CCS2. Together with shallow groundwater and near-surface monitoring (See Section 8 of this document), OLCV will monitor groundwater quality and geochemical changes above the Upper Confining Zone during the Injection Period for 16 TAC 5.203(j)(2)(D)(i) and (ii). The results of groundwater sampling will be compared to baseline geochemical and isotopic data collected during the site characterization baseline.

7.1 Monitoring Location and Frequency

OLCV models that the region around the UIC Class VI injector wells will experience the highest reservoir pressure resulting from CO₂ injection. The USDW1 well will monitor for potential loss of containment through the Upper Confining Zone or Upper Confining System. Because the size of the AoR is expected to remain small (<5 mi²), OLCV models that one well is sufficient to monitor the USDW. Additional monitoring wells for the USDW may be drilled in the future.

The integrity of the Upper Confining Zone will also be monitored by the SLR1 and ACZ1. Saturation logging (PNL or RST) may be conducted in the wells in the intermediate hole section

including the Grayburg and Upper San Andres formations. PNL and RST logs yield less reliable data through three casing strings, therefore, this method will not be appropriate for monitoring saturation in the lowermost USDW.

Monitoring above the Injection Zone that will be reported by the Project is summarized in Table 11.

Table 11—Monitoring above the Injection Zone reported by the Project.

Objective	Method	Frequency pre-injection	Frequency during injection	Frequency post-injection
First Permeable zone above the confining zone / lowermost USDW: Dockum				
Fluid and dissolved gas geochemistry in the first permeable zone above the Confining Zone / lowermost USDW	Fluid and dissolved gas sampling and analysis in USDW1	During construction and quarterly during baseline	Quarterly geochemical sampling in years 1-3 and annually starting in year 4; and event-driven*, triggered by P/T in SLR2 well or soil gas chemistry	Annually for first 10 years pending an approved PISC plan; and event-driven*, triggered by P/T in SLR2 well or soil gas chemistry
Upper Confining Zone integrity				
Pressure above the Injection Zone	P gauges in ACZ1, SLR1	Prior to injection	Quarterly monitoring of pressure gauge data	Quarterly monitoring of pressure until plugging

*OLCV will monitor pressure and temperature data obtained from downhole and surface gauges and downhole temperature from DTS fiber daily and routinely evaluate long-term data trends to detect deviations from the reference temperature or pressure gradient. If persistent deviations in temperature or pressure are detected, OLCV will obtain reservoir fluid samples and analyze fluid and dissolved gas chemistry to determine the presence or absence of increased CO₂. Saturation logging may also be conducted to further support or refute the presence of increased CO₂.

7.2 Description of Methods and Justification

See Section 8.1 for details on fluid sampling and analyses.

8.0 Monitoring the Near-Surface

The primary objectives of the near-surface monitoring program are to confirm containment of CO₂ within the Lower San Andres Injection Zone, demonstrate protection of the lowermost USDW, and to provide for early detection of anomalous conditions indicative of potential leakage of CO₂ or of brine migration. Water composition in shallow wells and soil gas within the near surface has considerable variation due to natural processes and naturally occurring events and due to anthropogenic processes unrelated to the Project. Such natural and anthropogenic variation

increases the difficulty of using only composition as the baseline for CO₂ leak and brine migration monitoring purposes. Instead, characterization of the subsurface system, including near-surface conditions (i.e., soil gas, fluid and dissolved gas chemistry of the deepest USDW; Section 7.0), and Injection Zone fluids (Section 6.0), provides a better approach for identifying unique tracers in the system that will potentially help identify an anomalous change in condition, and if needed, the source of the changes; and to discard false positives.

For the BRP Project, the lowermost USDW and soil gas analyses will be reported at the frequencies specified in Table 12.

Table 12—Monitoring the Near-Surface reported by the Project.

Objective	Method	Frequency pre-injection	Frequency during injection	Frequency post-injection
Fluid and dissolved gas geochemistry in the lowermost USDW	Fluid and dissolved gas sampling and analysis	During construction and quarterly during baseline	Quarterly geochemical sampling in years 1-3 and annually starting in year 4; and event-driven*, triggered by P/T in SLR2 well or soil gas chemistry	Annually for first 10 years pending an approved PISC plan; and event-driven*, triggered by P/T or soil gas chemistry
Soil gas analysis in the near-surface vadose zone	Isotopic analysis and chemical evaluation at 20 locations	Characterization prior to injection, including quarterly sampling for at least one year	Quarterly gas composition sampling in years 1-3 and annually starting in year 4 for subset of stations, and event-driven*, triggered by P/T data in SLR2 well and fluid sample results	Event-driven*, triggered by P/T data in SLR2 well and fluid sample results

*OLCV will monitor pressure and temperature data obtained from downhole gauges and/or DTS fiber daily and routinely evaluate long-term data trends to detect deviations from the reference temperature or pressure gradient. If persistent deviations in temperature or pressure are detected, OLCV will obtain reservoir fluid samples and analyze fluid and dissolved gas chemistry to determine the presence or absence of increased CO₂. In addition, fluid, and dissolved gas chemistry data from the lowermost USDW and soil gas chemistry from shallow soils will be monitored for trends to detect deviations from reference chemistry. If persistent and/or abrupt anomalies in chemistry are detected additional fluid or soil gas samples will be obtained to confirm the presence or absence of increased CO₂.

8.1. USDW Sampling

8.1.1 Monitoring Location and Frequency

The Project has drilled one well to monitor the Dockum group, the USDW1 well. The monitoring well is located near the BRP CCS1 and BRP CCS2 locations.

Fluid and dissolved gas samples were collected after the installation and adequate development of the USDW1. The initial sample from the USDW1 well was collected in March 2024, and it was

analyzed for geochemical and isotopic characterization. See Table 6d in the Quality Assurance and Surveillance Plan for a description of analytical methods used in the March 2024 sampling event. Following the March 2024 sampling event, OLCV re-selected a laboratory to accommodate samples from both the WW and the USDW1 wells. A revised list of analytical methods used for sampled obtained after March 2024 is shown in Table 13.

After CO₂ injection commences, USDW1 will be sampled for geochemical analysis and a subset of the isotopic analyses at a quarterly frequency in years one to three, then annually starting in the fourth year after commencement of CO₂ injection until the end of Injection Period. During the Post-injection Period of the Project, the USDW will be monitored annually for geochemical analysis and a subset of the isotopic characterization for the first 10 years. If anomalous soil gas chemistry is observed, anomalous pressure and temperature changes are observed in a SLR well, or there is any indication of leakage through the UIC Class VI injector wells during the injection and post-injection periods of the Project, additional fluid samples may be obtained for geochemical and isotopic analysis and comparison to pre-injection sample results. If geochemistry data of fluids and dissolved gases in the lowermost USDW are consistent with the absence of introduced Injection Zone brine or CO₂ injectate into the USDW, this monitoring method will be discontinued after 10 years post-injection.

Note that one legacy USDW-level well (State well number 4511701) drilled in 1940 was located in the AoR. OLCV evaluated this well and determined it had poor mechanical integrity. OLCV plugged and abandoned the well using hydrated Baroid 3/8” bentonite hole plug chips from 189 ft bgs to 5ft bgs and a cement slurry to the ground surface. There are no other legacy USDW-level wells within the AoR.

Table13--Summary of analytical parameters for fluid and dissolved gas samples during sampling events following March 2024 in the first permeable zone above the confining zone / lowermost USDW (Dockum Group).

Laboratory Analyte (Green Analytical for water geochemical analyses)	Analytical Methods ¹	Detection Limit / Range ²	Typical Precision ²	QC Requirements
<u>Total and Dissolved Metals:</u> Ag, Al, As, Ba, Cd, Co, Cr, Cu, Mn, Mo, Ni, Pb, Sb, Se, Sr, Th, Tl, U, V, and Zn	USEPA Method 200.8	0.00004 to 0.003 mg/L	±20	Daily calibration, Initial QC checks (ICV, ICB, RL) method blank, lab control samples, matrix spikes, and sample duplicate, CCV/CCB every 10 samples or part thereof
<u>Total and Dissolved Metals:</u> B, Ca, Fe, K, Mg, Li, Na, Si, Sr, Ti	USEPA Method 200.7	0.003 to 0.254 mg/L	±20	Daily calibration, Initial QC checks (IPC, ICV, ICB, RL) method blank, lab control samples, matrix spike, and matrix spike dup; CCV/CCB every 10 samples or part thereof

Total and Dissolved Hg	USEPA Method 245.7	19.6 ng/L	±20	Calibration as needed, daily QC checks; ICV, ICB, RL, method blank, lab control samples, matrix spike, and matrix spike dup; CCV/CCB every 10 samples or part thereof
Dissolved Inorganic Carbon (DIC); Dissolved Organic Carbon (DOC)	Standard Method 5310C	0.198 to 0.290 mg/L	±20	Calibration as needed, daily QC checks; ICV, ICB, RL, method blank, lab control samples, matrix spike, and matrix spike dup; CCV/CCB every 10 samples or part thereof
Dissolved CO ₂	Standard Method 4500 CO ₂ D	8 mg/L	±20	Frequent calibration, method blank, lab control samples, matrix spikes, and sample duplicate.
Alkalinity: Total, Bicarbonate, Carbonate, and Hydroxide	Standard Method 2320B	8 mg/L	±20	Method blank, lab control samples, matrix spikes
Major Anions: Br, Cl, F, SO ₄ , NO ₂ , NO ₃ as N, and PO ₄ as P	USEPA Method 300.0	0.003 to 0.563 mg/L	±20	Calibration as needed, daily QC checks; ICV, ICB, RL, method blank, lab control samples, matrix spike, and matrix spike dup; CCV/CCB every 10 samples or part thereof
Total and Dissolved P	USEPA Method 365.1	0.0215 mg/L	±20	Daily calibration, Initial QC checks (ICV, ICB, RL) method blank, lab control samples, matrix spikes, and sample duplicate, CCV/CCB every 10 samples or part thereof
Dissolved H ₂ S (Sulfide)	Standard Method 4500S2-D	0.026 mg/L	±20	Calibration as needed, daily QC checks; ICV, ICB, RL, method blank, lab control samples, matrix spike, and matrix spike dup
Total Dissolved Solids (TDS)	USEPA Method 160.1	10 mg/L	±20	Method blank, lab control samples, and sample duplicate
Conductivity	Standard Method 2510B	0 to 200 mS/cm	±1%	Calibration as needed, daily QC checks (1413, 14130 and second source SRM), CCV every 10 samples or part thereof
pH and Temperature	USEPA Method 150.1	0.1 to 14 pH units	±0.1 pH units	Daily calibration, second source SRM, CCV's every 10 samples or part thereof
Specific Gravity	ASTM Method D1429-03	NA	To the nearest thousandths decimal	Duplicates

Cation Anion Balance	Calculation	NA	±10	Calculation
<u>Organics</u> : Benzene, Toluene, Ethylbenzene, and Xylenes	USEPA Method 8260	0.001 to 0.003 mg/L	±20	Frequent calibration, method blank, lab control samples, matrix spikes, and sample duplicate.
Dissolved Gas Abundances: CO ₂ , CO, N ₂ , Ar, He, H ₂ , O ₂ , C1-C6+	In-house Lab SOP, similar to RSK-175	1 to 100 ppm, varies by component	C1-C4: ± 5%; C5-C6+: ± 10%	20% of all analyses are check/reference standards.
Dissolved Gas Isotopes: δ ¹³ C of C1-C5 and CO ₂ , δ ² H of C1	High precision (offline) analysis via Dual Inlet IRMS	Varies by component	δ ¹³ C: 0.1 per mil; δ ² H: 3.5 per mil	20% of all analyses are check/reference standards.
¹⁴ C of C1	AMS - subcontracted to Beta Analytic	0.44 pMC	± 1 to 2 pMC	Daily monitoring of instrumentation and chemical purity in addition to extensive computer and human cross-checks.
¹⁴ C of DIC	AMS - subcontracted to Beta Analytic	Depends on available sample volume	± 1 to 2 pMC	Daily monitoring of instrumentation and chemical purity in addition to extensive computer and human cross-checks.
δ ¹³ C of DIC	Gas Bench/CF-IRMS	Depends on available sample volume, minimum of 50mg/L required	0.20 per mil	20% of all analyses are either check/reference standards or duplicate analyses.
δ ¹⁸ O and δ ² H of H ₂ O	Analyzed via CRDS	N/A	δ ¹⁸ O: 0.10 per mil; δ ² H: 2.0 per mil	20% of all analyses are either check/reference standards or duplicate analyses.
⁸⁷ Sr/ ⁸⁶ Sr	TIMS - subcontracted to the University of AZ	Approximately 40 ppm	± 0.00002	SRM 987 Sr standard within the long-term precision (external precision) of +/- 0.00002 accepted value of 0.71025
²²⁸ Ra/ ²²⁶ Ra	USEPA Method 901.1	50 pCi/L (RL)	± 25%	Frequent calibration, method blank, lab control samples, matrix spikes, and sample duplicate.
Field Parameters				
pH (Field)	Standard Method 24500-H+ B-2000	2 to 12 pH units	±0.2 pH units	User calibration per manufacturer recommendation
Specific conductance (Field)	EPA Method 120.1	0 to 200 mS/cm	±1%	User calibration per manufacturer recommendation
Temperature (Field)	Standard Method 2550 B-2000	-5 to 50 °C	±0.2 °C	Factory calibration
Oxidation-Reduction Potential (Field)	Standard Method 2580	-1999 to +1999 mV	±20 mV	User calibration per manufacturer recommendation

Dissolved Oxygen (Field)	ASTM Method D888-09 (C)	0 to 50 mg/L	0 to 20 mg/L: ±0.1 mg/L or 1% of reading, whichever is greater; 20 – 50 mg/L: ±8% of reading	User calibration per manufacturer recommendation
Turbidity (Field)	USEPA Method 180.1	0 to 1000 NTU	± 1% of reading or 0.01 NTU, whichever is greater	User calibration per manufacturer recommendation

¹An equivalent method may be employed with the prior approval of the UIC Program Director.

²Detection limits and precision (laboratory control limits) are typical for these analytical methods.

*Analytical parameters to be included during the Pre-injection Period, and only as needed during the Injection and Post-injection Periods of the Project.

8.1.2. Description of Methods and Justification

The purpose of monitoring above the Upper Confining Zone is to identify potential geochemical changes due to the introduction of CO₂ injectate stream or displaced formation fluids above the Upper Confining Zone. Unlike some injected materials regulated by UIC, the presence of CO₂ in groundwater, surface water or soils may be the result of naturally occurring biological processes. Therefore, the presence of CO₂ in shallow or surface intervals is not necessarily diagnostic of leakage from an Injection Zone (Romanak, 2012). Furthermore, it may be impossible to establish a meaningful baseline CO₂ concentration, because the concentration of CO₂ in soils and groundwater is changing overtime due to global climatic changes (Bond-Lamberty, 2010; Macpherson, 2008; and Burger, 2020). However, the monitoring plans for the BPR project is designed to establish observable trends to characterize variabilities and changes due to natural processes and anthropogenic sources during the baseline period of the Project.

In addition to establishing a baseline, OLCV plans to use a process-based approach along with natural tracers to characterize and attribute CO₂ measured in groundwater. The process-based approach involves characterizing groundwater prior to the commencement of injection operations. For the purpose of characterizing groundwater prior to injection while accounting for variations due to existing natural processes (and anthropogenic sources other than those injected by OLCV, if any), multiple samples will be collected during pre-injection activities. Similarly, multiple soil gas samples from across the AoR will be used to characterize the naturally occurring variability across the site. See Section 8.2 in this document for more information on soil gas characterization.

For the process-based approach using natural tracers in groundwater, Romanak (2012) recommends characterizing $\delta^{13}\text{C}$, ^{14}C , CH₄, and δD in the fluids throughout the stratigraphic column. These isotopes can be used to trace carbon reactions. The initial characterization is intended to define components that will be diagnostic for future monitoring. In order to attribute

the source of CO₂ or other relevant compounds, isotopic characterization will also be performed on the CO₂ injectate stream, fluids from the Injection Zone, fluids in first permeable layer above the Injection Zone, and fluids and dissolved gases from the USDW.

To monitor changes, Romanak (2014) suggests using the covariation of $\delta^{13}\text{C}$ and ^{14}C as natural tracers. $\delta^{13}\text{C}$ in anthropogenic sources overlaps the signature of naturally occurring biologic sources, so the data should be considered in context with other lines of evidence. However, ^{14}C in CO₂ is interpreted to be diagnostic between anthropogenic and naturally occurring sources. The BRP Project has a unique challenge in that the source of the CO₂ injectate is captured directly from the ambient air that may contain signatures of multiple anthropogenic sources rather than from a specific industrial anthropogenic source, thus the ability to use the variation of $\delta^{13}\text{C}$ and ^{14}C for attribution is not well-studied.

To support the interpretation of the isotopic characterization of the natural tracers such as the variation of $\delta^{13}\text{C}$ and ^{14}C , geochemical properties of the lowermost USDW fluid will be characterized and a baseline will be established. Geochemical changes in the Dockum group may occur after the inadvertent introduction of foreign fluids or gases to the aquifer through a leakage pathway or conduit (i.e., CO₂ and/or brine migration from the target injection formation) during the injection period of the Project (EPA, 2013).

At the end of the pre-injection baseline period, OLCV will determine if geochemical and isotopic trends, including seasonal variations, are present. The baseline characterization and any trends will be used to create procedures for CO₂ and brine leakage identification and characterization in the Dockum group during the injection and post-injection periods of the BRP Project.

Fluid and dissolved gas samples in the USDW1 will be collected in appropriate containers provided by the laboratories according to EPA best practices by a qualified and experienced third-party contractor(s) as described in the QASP. All sample containers will be labeled with a unique sample identification number and sampling date, written with durable labels and indelible markings. The water samples will be preserved appropriately, as required by the specific analytical methods, and shipped within 24 hours of collection to certified laboratories, under chain-of-custody control.

Groundwater analyses from the Dockum group will be performed by third-party laboratories accredited with the EPA and/or the Texas Commission on Environmental Quality (TCEQ), following the specific methods approved by EPA or alternative methods (e.g., ASTM Methods or Standard Methods). Operators might audit the procedures and results of the selected laboratories with a third party to review laboratory internal quality control procedures. The samples will be analyzed by a third-party laboratory using standardized procedures for various instruments including for gas chromatography, mass spectrometry, detector tubes, and photo ionization. Sampling methods and chain of custody procedures are described in the QASP.

OLCV personnel experienced in fluid geochemical and isotopic analyses will evaluate the analytical reports provided by the laboratories who analyzed the fluid samples. These data will be compared with previous measurements to look for trends or changes in chemical composition. Groundwater results will be evaluated along with pressure and temperature data to determine the presence or absence of Injection Zone fluid or fluid migration above the Upper Confining Zone.

An anomalous detection of CO₂ above background levels in the USDW “does not necessarily demonstrate that USDWs have been endangered, but it may indicate that a leakage pathway or conduit exists” (EPA, 2013b). Therefore, if it is determined that a departure between observed and baseline parameter patterns appears to be related to a potential CO₂ leak from the Injection Zone, additional testing of the USDW may be conducted. If OLCV personnel interpret that fluids or gases from the Injection Zone may be leaking into the lowermost USDW, the source of the potential leak will be investigated, and appropriate corrective actions will be taken to protect the drinking water resources within the AoR.

The elements of the USDW monitoring program may be modified throughout the baseline, injection, and post-injection periods of the Project, as needed, and with approval of the Director, as more data and information become available for the Project.

8.2. Near-Surface Soil and Soil Gas Sampling

8.2.1 Monitoring Location and Frequency

The collection of soil gas data within the AoR will aid in the identification, characterization, and source-attribution of CO₂ encountered in the near-surface. The evaluation of near-surface data is complicated by the variations in natural processes in the vadose zone (e.g., root respiration, biologic respiration, microbial oxidation of methane), anthropogenic sources unrelated to the BRP Project (e.g., nearby oil and gas production), gases from deeper zones (e.g., shallow groundwater), and atmospheric exchanges driven by barometric differences, which can be seasonal (NETL, 2017). As stated by the EPA (2023b), background soil CO₂ concentrations and isotopic compositions are largely “dependent on exchange with the atmosphere, organic matter decay, uptake by plants, root respiration, deep degassing, release from groundwater due to depressurization, and microbial activities.” Therefore, some component of soil gas monitoring during the baseline period of the Project is useful to i) define the baseline molecular and isotopic compositions of the shallow soil gas, and ii) characterize natural background variability, including seasonal trends. The results of the pre-injection soil gas monitoring may then be used for future reference and comparison to operational soil gas monitoring to assist in the detection, validation, and quantification of potential CO₂ leakage. To this end, a soil gas monitoring program will be conducted during pre-injection and injection utilizing permanent soil gas probes as an active, whole air, sample collection method.

Permanent subsurface soil gas probes were installed in June-July 2024 at 20 representative locations throughout the surface projection of the AoR and adjacent DAC facility. The following factors were considered in siting soil gas probes: the location of artificial penetrations discussed the Area of Review and Corrective Action Plan; variable surface soil characteristics, such as caliche deposits; the potential effects of the DAC facility on natural processes in the near-surface; and the location of adjacent property owners. Three probe stations are located near the UIC Class VI injector wells, where highest pressures and risks of vertical migration are expected. One probe station is located near each artificial penetration within the AoR (i.e., the BRP verification/monitoring wells and legacy artificial penetrations wells). Two probe stations are located near the DAC facility and three probe stations are located along the southern boundary of the Shoe Bar Ranch near the adjacent private property.

The elements of the soil gas monitoring program may be modified throughout the pre-injection and injection periods of the Project, as needed, as more data and information become available for the Project site.

8.2.2 Description of Methods and Justification

Soil gas characterization and monitoring will be used in concert with fluid analyses to conduct a process-based approach according to the principles described in Romanak (2012). The process-based approach is based on the observation that for every one volume percent of O₂ that is utilized by a microbe during respiration, one volume percent of CO₂ is produced. This relationship of O₂ to CO₂ forms a respiration trend line. Samples that plot to the left of the respiration line indicate natural biological processes. Samples that plot to the right of the respiration line indicate that excess CO₂ has entered the soil (see Figure 5). The source of the excess CO₂ could potentially be attributed to leakage from an injection site, or leakage from a geologic source such as the mantle, or an anthropogenic source other than the BRP Project.

In addition, Romanak (2012) suggests that using the ratio of N₂ to CO₂ (Figure 5) can be used to detect anomalous introductions of CO₂ into a system. An increase in CO₂ can result in relative dilution of N₂ in percent gas concentration. This relative reduction in N₂ may indicate a deviation from the natural signal and could be result of CO₂ leakage. In the cases of CO₂ v. O₂ and CO₂ v. N₂, the naturally occurring ratios are consistent despite seasonal or longer-term variability (Figure 5). Variability due to short or long term naturally occurring processes fall along the same trend, but at different points on the line.

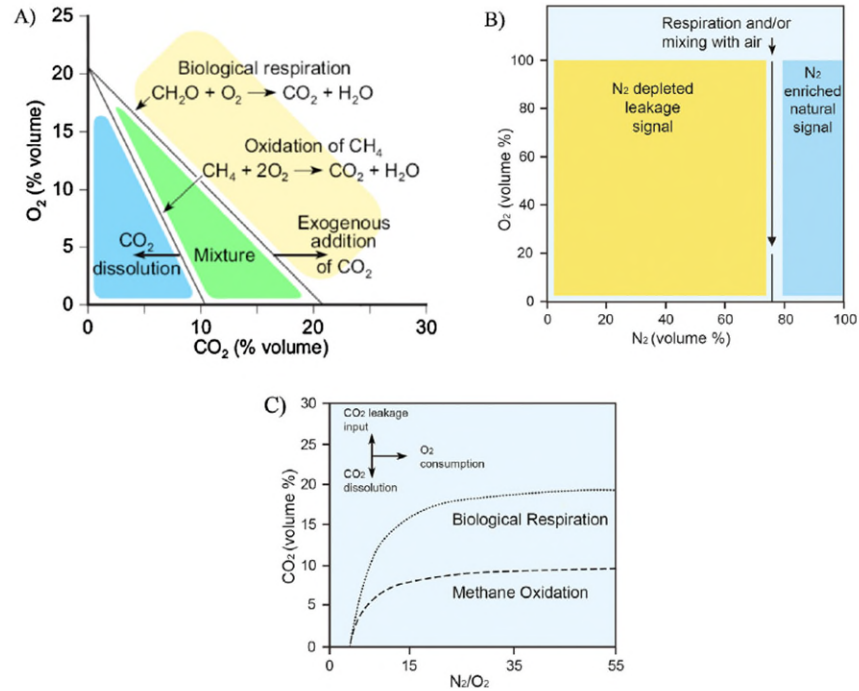

Figure 5—Process based approach for characterizing CO₂ source (modified Romanak, 2014)

As a result, the collection of soil gas samples for gas composition analysis can provide valuable information in the source attribution process for the presence of CO₂ and other gases in the vadose zone. However, the evaluation of the composition gas can be obscured in the light of the various biological processes present in the subsurface which produce or consume CO₂ (Romanak, 1997). Therefore, the collection and analysis of hydrocarbon gas as well as natural tracers ($\delta^{13}\text{C}$ and ^{14}C) can increase confidence in the interpretation of the data and the attribution of the CO₂ sources (i.e., natural vs. anthropogenic). Several studies have also demonstrated that analysis of soil gas for stable isotopes ($\delta^{13}\text{C}$ and δD) and hydrocarbons (C₂-C₃) can help determine whether the presence of the CO₂ and methane is due to natural biological processes or from thermogenic sources (e.g., reservoir deep gas) (Romanak, 2014).

Soil gas probe sites were installed to a depth of approximately 10 feet below ground level (Figure 6), dependent upon the depth to shallow groundwater and presence of low-permeability (e.g., clay) zones, utilizing either a direct-push (e.g., GeoProbe®) or hand-auger drilling equipment. During borehole advancement, a continuous soil core was collected and logged in accordance with Unified Soil Classification System (USCS) guidelines to determine soil type.

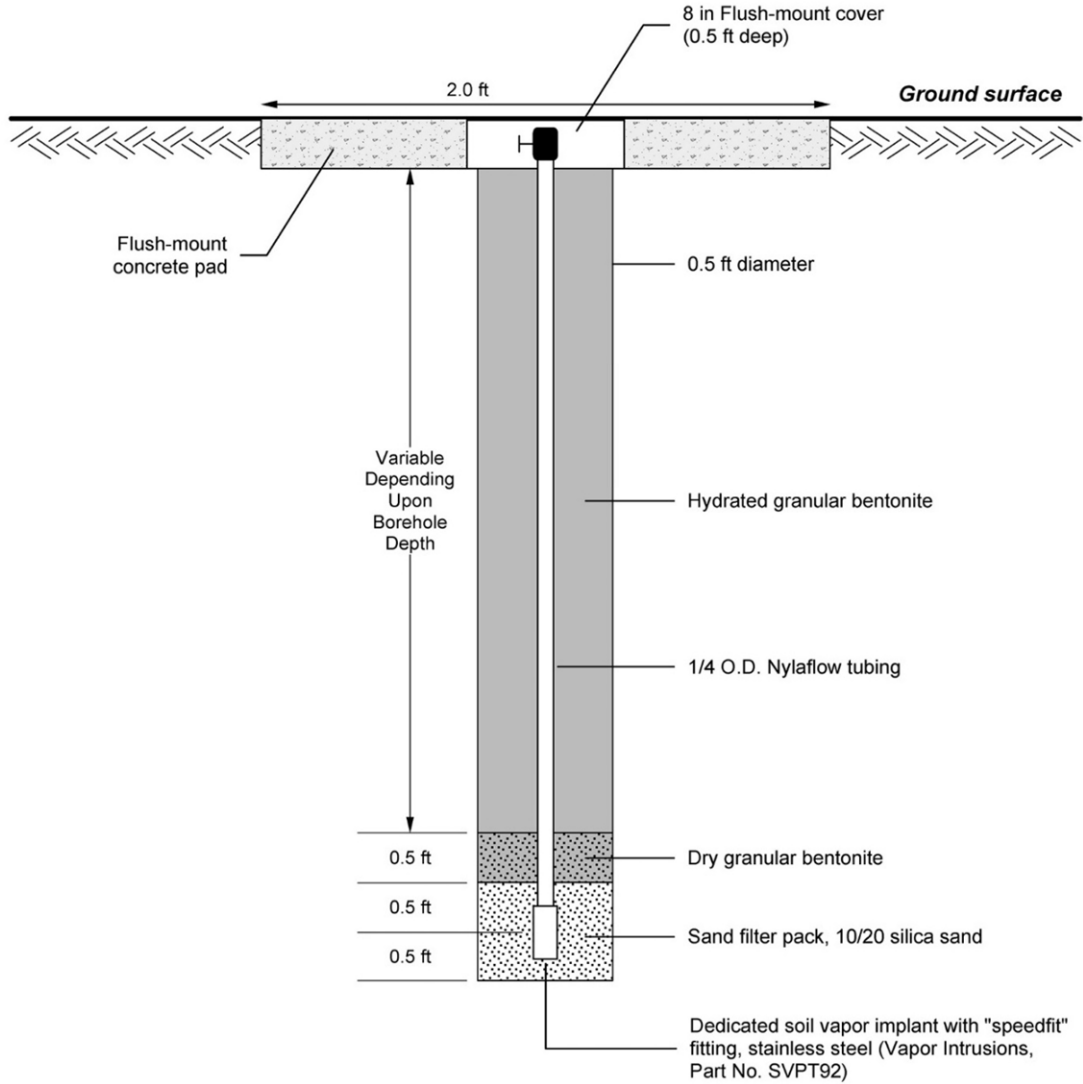

Figure 6— General soil gas probe station construction schematic for BRP Project.

The location of soil gas probes and other monitoring equipment is shown in Figure 7.

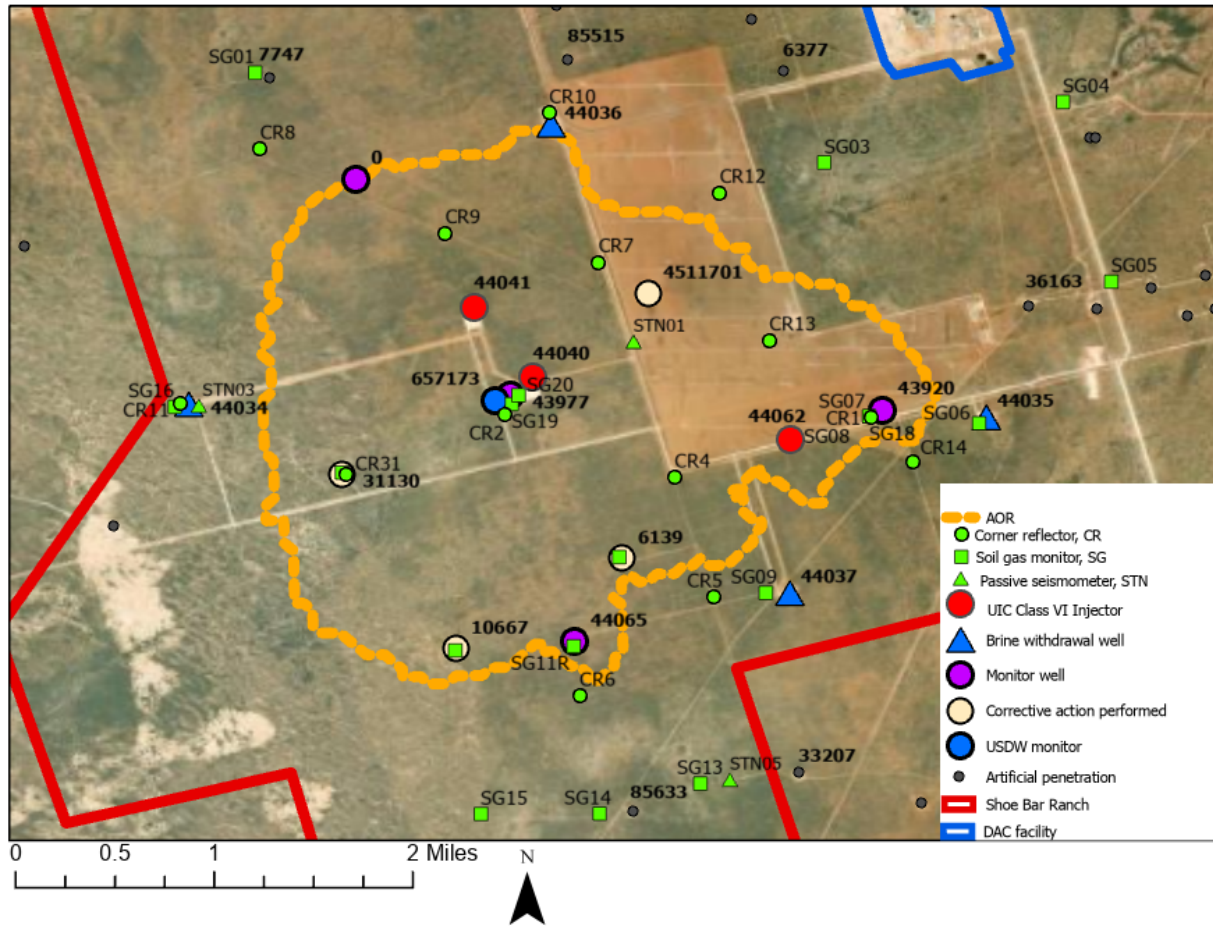

Figure 7— Map of BRP Project area including outline of Shoe Bar Ranch, the combined CO₂ plume and pressure plume (the AoR), wells, facilities, and monitoring locations. Explanation: SG = Soil gas monitor, CR = Corner Reflector, STN = seismometer station, AP = Artificial Penetration, DAC = Stratos Direct Air Capture Facility.

Soil samples were collected in general accordance with EPA Method LSASDPROC-300-R5 (EPA, 2023a) for the laboratory analysis of pH, electrical conductivity, sodium adsorption ratio, total organic carbon (TOC), and soil moisture, in accordance with the methods specified in Table 14 below.

Table 14—Soil and soil gas analysis parameters.

Parameter	Analytical Method
Soil Analyses	
pH	EPA Method 9045D
Electrical Conductivity (EC)	29B_EC
Sodium Adsorption Ratio (SAR)	29B SAR
Total Organic Carbon (TOC)	Walkley Black 9060A
Moisture	SW3550
Soil Gas Analyses	
Composition gas: H ₂ , He, O ₂ , N ₂ , CO ₂ , CH ₄ , CO, Ar, C ₂ -C ₆ +	In-house Lab SOP, similar to RSK-175
*δ ¹³ C of CH ₄ and CO ₂ , δ ² H of Methane	High precision (offline) analysis via Dual Inlet IRMS
*C ¹⁴ of CO ₂	Accelerated mass spectrometry

Note:

* = Analytical parameters to be included during the pre-injection period, and only as needed during the injection and post-injection periods of the Project.

Following soil sampling, OLCV conducted soil gas sampling at the probe stations following the procedures set forth in EPA Method SESDPROC-307-R5 (EPA, 2023b) and industry standards ASTM D7648/D7648M-18, for laboratory analysis of the following constituents.

- H₂, He, O₂, N₂, CO₂, CH₄, CO, Ar, C₂-C₆+
- δ¹³C of CH₄ and CO₂, δ²H of CH₄
- ¹⁴C of CO₂

During soil gas sampling, a leakage test was conducted by releasing helium gas as a tracer gas within a shroud over each soil gas sampling site. See QASP 2.2.1.4 for details on sampling and QASP Table 7 for analysis methodologies.

Additional soil gas samples will be collected on a quarterly basis for approximately one year prior to the commencement of CO₂ injection at the BRP Project site. These samples will be analyzed for geochemical and isotopic composition shown in Table 14 to evaluate and characterize the near-surface conditions prior to CO₂ injection. After CO₂ injection commences, the soil gas probe stations will be sampled quarterly between year one to three. Then a subset of the soil gas stations will be strategically selected based on the previous data collected and sampled for gas composition analysis annually starting in year four. In addition, during the injection and post-injection periods of the Project, if anomalous pressure and temperature changes are observed in the SLR wells, or there is any indication of CO₂ leakage through the UIC Class VI injector well, additional soil gas samples may be collected for gas composition and/or isotopic analysis and comparison to pre-injection results.

OLCV or Oxy personnel and/or their contractors experienced in soil analysis and gas composition and isotopic analysis will evaluate the samples. These results will be compared with previous

measurements to look for trends or changes in chemical composition and distinguish major processes involved in the subsurface which impact the gas composition. The evaluation of soil gas composition and isotopic data will also be coupled with evaluation of other fluids samples, as well as pressure and temperature data to interpret the presence or absence of CO₂ or other gases from the Injection Zone.

As mentioned in Section 8.1, an anomalous detection of CO₂ above background levels in soil gas “does not necessarily demonstrate that USDWs have been endangered, but it may indicate that a leakage pathway or conduit exists” (EPA, 2013b). Therefore, if a departure from baseline/ seasonal parameter patterns is observed, additional testing of soil gas, the atmosphere, and/or the USDW may be conducted. If OLCV personnel interpret that fluids from the Injection Zone may be leaking, the source of the potential leak will be investigated, and appropriate corrective will be taken to protect the drinking water resources within the AoR.

9.0 Internal and External Mechanical Integrity Testing

OLCV will conduct tests to verify the internal and external mechanical integrity of the UIC Class VI injector wells before and during the Injection Period [16 TAC 5.203(h)(1)(D), and 5.203(h)(1)(B)].

The purpose of internal mechanical integrity testing is to confirm the absence of significant leakage within the injection tubing, casing, or packers. Annulus pressure tests will be conducted at least once every five years to confirm internal mechanical integrity.

The purpose of external mechanical integrity testing is to confirm the absence of significant leakage outside of the casing. OLCV proposes to conduct a temperature profile of DTS data in the UIC Class VI injector wells at least once per year to demonstrate external mechanical integrity. Wireline temperature logging, or an equivalent or better method, may be substituted in the case that DTS does not provide the required information. Ultrasonic tools such as the UltraSonic Imager Tool (USITTM), or IsoScanner are industry-standard tools that provide information on wellbore integrity.

9.1 Testing Location and Frequency

Table 15 below provides a summary of the internal and external mechanical integrity monitoring methods and mechanical integrity testing (MIT) plans.

To demonstrate internal mechanical integrity of the UIC Class VI injector wells, OLCV will perform annular pressure tests during well construction and at least once every five years thereafter, coincident with well maintenance operations in which tubing and packer are pulled.

Additional testing will be conducted if the pressure or temperature data collected from gauges or DTS indicates a potential reduction in mechanical integrity.

External mechanical integrity monitoring on UIC Class VI injector wells will be continuously conducted via DTS fiber resulting in a temperature profile that is expected to meet and exceed the requirement of annual testing. OLCV may collect additional mechanical integrity logs such as an electromagnetic pipe examiner or casing inspection log. Logging will be conducted during well maintenance events to minimize disruption to the injection schedule. If DTS data indicate potential loss of mechanical integrity, OLCV will acquire an additional mechanical integrity log.

OLCV engineers will monitor downhole P/T data to look for changes that could indicate leakage inside the annulus or outside of the casing. If anomalous measurements are recorded, OLCV personnel will immediately conduct further investigations to determine if there is evidence of surface leakage and take appropriate corrective action. If no surface leakage is detected, OLCV personnel will continue to evaluate the source of the anomalous data and may choose to conduct an annulus pressure test, wireline conveyed P/T gauge, or other logging tool to investigate the borehole integrity. If anomalous data is not found to be the result of operational changes, such as a rate change, injection operations in the affected well will be ceased until the source of the anomalous data is determined and/or corrective action is applied.

Table 15—Internal and External Mechanical Integrity Monitoring Methods and Frequency reported by the Project.

Internal Mechanical Integrity				
Location	Method	Pre-Injection	Injection	Post-Injection
UIC Class VI Injector wells	Annular pressure test	During construction and prior to injection	After well interventions and at least once every five-year period; and before plugging	NA
SLR and ACZ wells	Annular pressure test	NA	After well interventions and at least once every five-year period	After well interventions and at least once every five-year period; and before plugging
External Mechanical Integrity				
	Method	Pre-Injection	Injection	Post-Injection
UIC Class VI Injector wells	DTS or other logging method that provides equivalent or better data	Prior to injection	Annual static profile; continuous monitoring	NA
SLR and ACZ wells	DTS or other logging method that provides	NA	Static profile once every five-year period and after well interventions	Static profile once every five-year period and after well interventions

	equivalent or better data			interventions; and before plugging
--	---------------------------	--	--	------------------------------------

9.2 Description of Methods and Justification

9.2.1 Internal Mechanical Integrity Using Annular Pressure Tests

An annular pressure test is a common method to demonstrate internal mechanical integrity. The test is based on the assumption that pressure applied to fluids in the annular space should be constant unless there are significant changes in temperature or a fluid leak.

An overview of the annular pressure test procedure is as follows:

- Shut in the well to stabilize the pressures in the well.
- Connect the testing equipment to the annular valves and test surface lines to 1,500 psi above the testing pressure.
- Ensure there are no surface leaks from the pumping unit to the wellhead valve.
- Bleed any air in the system. If needed, fill the annular space with packer fluid and corrosion inhibitor (if so, it should require only a minimal amount).
- Record the initial tubing and casing pressure. The well will be tested to 500 psi in the annular space, and the pressure should not decrease more than 5% in 30 minutes.
- Monitor the tubing and casing pressures continuously. Record the final tubing and casing pressure, then bleed the pressure and volume. If the pressure decreases more than 5%, bleed the pressure, test the surface connection, and repeat the test. If there is an indication of mechanical failure, the operator will prepare a plan to repair the well and discuss it with the Program Director.

9.2.2 Internal and External Mechanical Integrity Using DTS

OLCV installed a fiber optic cable alongside the casing in the UIC Class VI injector wells, SLR2 and SLR1, and secured the cable with clamps. The fiber is connected at the surface to an interrogator that converts the signal to temperature values, and the data are transmitted to the monitoring platform in real time for surveillance purposes. These data can provide high-resolution temperature data that can be used to detect subtle changes in fluid movement in a wellbore. Additional information on DTS technology can be found in Appendix A of this document.

Based on comparison of DTS data with data obtained via a conventional temperature log, OLCV recommends that external mechanical integrity testing be conducted utilizing DTS in lieu of temperature logging.

9.2.3 External Mechanical Integrity Testing Using Logging Tools

OLCV proposes to use an ultrasonic tool such as the Isolation Scanner™, or UltraSonic Imager Tool (USIT™). The tools are readily available technologies on the market and are commonly used to demonstrate external mechanical integrity. OLCV may also recommend that these tools be used to demonstrate external mechanical integrity on the UIC Class VI injector wells, following a comparison of results with conventional temperature logging.

In the future, new technologies or tools may be proposed for further discussion with regulators. Additional details on tools can be found in Appendix A of this document.

10.0 Pressure Fall-Off Testing

OLCV will perform a pressure fall-off test prior to injection and during the Injection Period as described below [16 TAC 5.203(j)(2)].

10.1 Testing Location and Frequency

The table below summarizes the pressure fall-off testing plan for the UIC Class VI injector wells.

Table 16—Summary of pressure fall-off testing.

Method	Pre-Injection	Injection	Post-Injection
Fall-off Testing	Prior to injection	At least once every five years during workovers	N/A

Pressure fall-off testing was conducted upon completion of the UIC Class VI injector wells to characterize reservoir hydrogeologic properties, aquifer response characteristics, and changes in near-well/reservoir conditions that may affect operational CO₂ injection behavior.

Following the commencement of injection operations, pressure fall-off testing will be conducted at least once every five-year period during injection and before well plugging. The objective of the periodic pressure fall-off testing is to determine whether any significant changes in the near-wellbore conditions have occurred that may adversely affect the well or reservoir performance.

10.2 Description of Methods and Justification

Pressure fall-off testing is a method of monitoring changes that may impact injectivity or pressure response in the near-wellbore environment. Additionally, pressure fall-off testing can be used to monitor wellbore mechanical integrity. The fall-off test is conducted by ceasing injection for a designed time period and continuously monitoring the pressure and temperature with downhole gauges. The duration of the test is designed to measure the pressure recovery.

Pressure fall-off testing is a proven technology that is widely used in subsurface well operations. The results of pressure fall-off tests will be interpreted by engineers and geologists who are experienced in analyzing this type of data. Experienced senior advisors will be consulted to add additional technical insight. The interpretation will be used to confirm or update operational parameters and confirm wellbore mechanical integrity.

Pressure gauges used to conduct fall-off tests will be calibrated in accordance with the manufacturers' recommendations. In lieu of removing the injection tubing to recalibrate the downhole pressure gauges, their accuracy will be demonstrated by comparison with a second pressure gauge with current certified calibration, which will be lowered into the well to the same depth as the permanent downhole gauge. Calibration curves for the downhole gauge, based on annual calibration checks using the second calibrated gauge, can be used for the fall-off test. These calibration curves (showing all historic pressure deviations) will accompany the fall-off test data.

10.3 Interpretation of fall-off test results

Quantitative analysis of the pressure fall-off test response provides the basis for assessing near-well and larger-scale reservoir behavior. Comparison of diagnostic pressure fall-off plots measured before CO₂ injection and during the injection period can be used to determine whether significant changes in well or storage reservoir conditions have occurred. Diagnostic derivative plot analysis (Bourdet et al., 1989; Spane, 1993; Spane and Wurstner, 1993) of the pressure fall-off recovery response is particularly useful for assessing potential changes in well and reservoir behavior.

Plotting the downhole temperature concurrent with the observed fall-off test pressure is useful to check for anomalous pressure fall-off recovery response. Commercially available pressure gauges typically are self-compensating for environmental temperature effects within the probe sensor (i.e., within the pressure sensor housing). However, if temperature anomalies are not accounted for correctly (e.g., well/reservoir temperatures are responding differently than registered within the probe sensor), erroneous pressure fall-off response results may be derived. Thus, concurrent plotting of downhole temperature and pressure fall-off responses is useful for assessing whether temperature anomalies may be affecting pressure fall-off recovery behavior. In addition, diagnostic pressure fall-off plots should be evaluated relative to the sensitivity of the pressure gauges used to confirm adequate gauge resolution (i.e., excessive instrument noise).

Standard diagnostic log-log and semi-log plots of observed pressure change and/or pressure derivative plots vs. recovery time are commonly used as the primary means for analyzing pressure fall-off tests. In addition to determining specific well performance conditions (e.g., well skin) and aquifer hydraulic property and boundary conditions, the presence of prevailing flow regimes can be identified (e.g., wellbore storage, linear, radial, spherical, double-porosity) based on characteristic diagnostic falloff pressure derivative patterns. A more extensive list of diagnostic

derivative plots for various formation and boundary conditions is presented by Horne (1990) and Renard et al. (2009).

Early pressure fall-off recovery response corresponds to flow conditions in and near the wellbore, whereas later fall-off recovery response is reflective of reservoir conditions progressively farther from the UIC Class VI injector well location. Significant divergence in pressure fall-off response patterns from previous tests (e.g., accelerated pressure fall-off recovery rates) may be indicative of a change in well and/or reservoir conditions (e.g., leakage). A more detailed discussion of using diagnostic plot analysis of pressure falloff tests for discerning possible changes to well and reservoir conditions is presented by the EPA (2002).

11.0 Carbon Dioxide Plume and Pressure Front Tracking

OLCV will monitor the CO₂ plume and pressure front using indirect methods [16 TAC 5.203(j)(2)(E)].

11.1 Monitoring Location and Frequency

Indirect tracking methods include:

- Saturation logging in SLR2 to estimate CO₂ near the wellbore;
- Evaluation of the geometry of the CO₂ plume and pressure front using time-lapse 2D VSP and 2D surface seismic;
- Satellite-based Differential Interferometric Synthetic Aperture Radar (DInSAR) and Global Positioning System (GPS) data that measure ground deformation; and
- Calibration of the dynamic simulation model for the AoR re-evaluation.

Table 17—Indirect methods of tracking the CO₂ plume and pressure front reported by the Project.

Indirect Methods				
Objective	Method	Pre-Injection	Injection	Post-Injection
Estimate CO ₂ saturation in the Injection Zone	PNL or RST in SLR2 well	Prior to injection	Annually	Annually until plugging
Estimate CO ₂ plume and pressure extent in the Injection Zone	2D VSP in UIC Class VI injector wells	Prior to injection	2D VSP at years 1, 2, 5 and 10	NA
	2D VSP in selected SLR2 well	Prior to injection at SLR2	2D VSP in year 5 or 10	Once approximately every five-year period until plugging or plume stabilization
	2D surface seismic	Prior to injection	Year 10	Once approximately every five-year period until plume stabilization
	DInSAR with GPS	Prior to injection	Quarterly	Annually for five years or until plume stabilization
	Computational modeling	Prior to injection	As needed, to be used for AoR re-evaluation	As needed, to be used for AoR re-evaluation

*OLCV will monitor pressure and temperature data obtained from downhole and surface gauges and downhole temperature from DTS fiber daily and routinely evaluate long-term data trends to detect deviations from the reference temperature or pressure gradient. If persistent deviations in temperature or pressure are detected, OLCV will obtain reservoir fluid samples and analyze fluid and dissolved gas chemistry to determine the presence or absence of increased CO₂. Saturation logging may also be conducted to further support or refute the presence of increased CO₂.

11.2 Description of Methods and Justification

The proposed methods are proven technologies and have been used by the Oxy and OLCV to safely conduct subsurface operations for decades. Additional new technologies will be considered in a cost versus benefit analysis and added to the plan if they are deemed to be warranted.

11.2.1 Saturation Detection Tool Method

Saturation logs (RST or PNL) will be run through the tubing to detect changes in CO₂ saturation and identify position of the CO₂ plume. The pulsed neutron log is considered a proven technique to detect gas saturation in reservoirs. Advances in technology have improved the accuracy of the tool for tracking movement of CO₂ plumes and evaluating conformance. Saturation logging methods are described in Appendix A to the Testing and Monitoring Plan.

OLCV plans to collect saturation logs in SLR2 well on an annual basis. These data will provide a record to track potential changes in fluid over time in the Injection Zone. Saturation logs may be collected in the WW wells or in the UIC Class VI injectors, if needed for calibration.

11.2.2 Repeat Seismic Methods

Baseline seismic acquisition

OLCV collected 2D and 3D surface seismic in 2022 to support site characterization. The 3D data were acquired in an area of approximately 20 mi² and extend approximately one mile beyond the AoR. Approximately 10 miles of 2D surface seismic was acquired. The survey was designed with a high density of sources and receivers to image from the near surface down to basement. Vibroseis was used as the source for the acquisition. The processing sequence included pre-processing, pre-stack depth migration and velocity model building, followed by post-migration processing.

Justification of time-lapse seismic methods

OLCV integrated the results of the 2D and 3D seismic with rock and fluid properties measured in the Shoe Bar 1 and Shoe Bar 1AZ to screen for detectability of a geophysical response resulting from a change in fluid or pressure in the Injection Zone. Figure 8 shows a forward model based on the Shoe Bar 1AZ that models the geophysical response resulting from 20% CO₂ saturation in porous (>8p.u.) zones over a ~500 ft thick carbonate. This screening result demonstrates the subtlety of time-lapse changes to sonic and density logs in the Injection Zone.

The detectability of a change in fluid or pressure is improved by utilizing wellbore seismic methods, therefore OLCV proposes to acquire seismic using a VSP in wellbores. Modeling conducted by OLCV indicates that 2D VSP is an appropriate seismic method. Because of the low dip on the Injection and Confining Zone units, 3D VSP is not modeled to yield a significant advantage over 2D VSP, and therefore 2D VSP is proposed for this study.

The imaging area of a VSP is limited to ~3500 – 3800 feet away from the wellbore, based on modeling conducted by OLCV and a third-party contractor. To image the full extent of the AoR, OLCV proposes to acquire 2D surface seismic in a radial pattern centered near the surface location of the UIC Class VI injector wells. For surface methods, the detectability of a time-lapse response resulting from a change in fluid or pressure improves with higher concentrations of CO₂. Therefore, surface seismic will be used as a monitoring technique in the later part of the injection period and in the post-injection period.

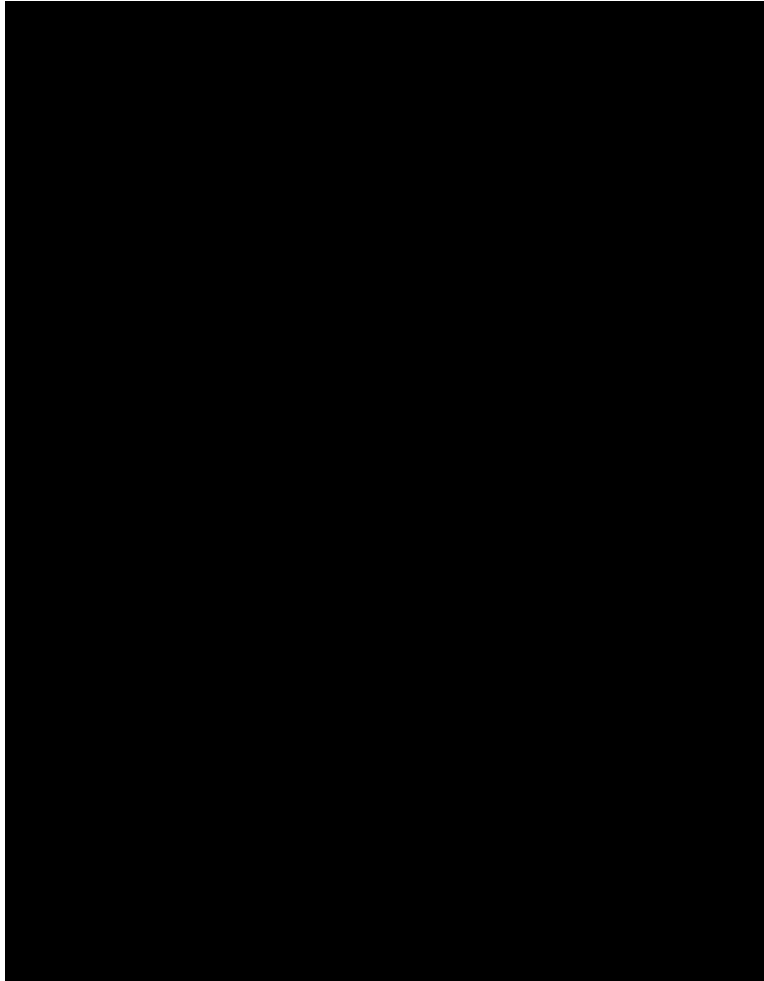

Figure 8—Example of forward modeled seismic response resulting from 20% CO₂ saturation at Shoe Bar 1AZ. Model shows a significant low impedance shift compared to the brine saturated base case.

Timing of baseline and repeat seismic acquisition

Following drilling and prior to commencement of injection, a 2D VSP baseline was acquired in the UIC Class VI injector wells and the SLR2 well. The UIC Class VI injector wells are designed to contain DAS fiber to the top of the Injection Zone. OLCV may also collect 2D VSP in the SLR1 and SLR3 monitoring wells in the future. In event that DAS fails, or if a VSP will be collected in a well without DAS, a borehole geophone array can be deployed for data acquisition.

Baseline surface 2D seismic was acquired in a radial pattern around the wells, concurrent with baseline VSP survey acquisition. The acquisition was conducted using conventional Vibroseis vehicles. The surface acquisition was dense to improve imaging from throughout the stratigraphic column from surface to basement.

Following the commencement of CO₂ injection, time-lapse 2D VSP surveys will be conducted in the UIC Class VI injector wells at approximately 12 months and 24 months, using a subset of the

Plan revision number: 7

Plan revision date: 05/25/2026

baseline data. The SLR2 well is anticipated to be incorporated into the 2D VSP acquisition at years 5 and 10, coinciding with the anticipated arrival of the predicted plume within the well's seismic imaging radius. The purpose of these surveys is to provide high-resolution, early indicators of plume orientation. The timing of future VSP acquisitions are planned to provide information for AoR re-evaluation, at approximately five and 10 years after the start of injection.

Repeat surface 2D is planned to occur at approximately year 10 following the commencement of CO₂ injection. The repeated acquisition will serve as a representative subset of the baseline acquisition, selected according to predictive plume geometry. Based on the detectability and resolvability observed with this survey, 2D surface acquisition may continue throughout the post-injection period at an interval of approximately once every five years, or until plume stabilization.

All planned seismic acquisition activities are expected to be conducted between October and March to accommodate the inactivity period of the Dune Sagebrush Lizard. If data collected with repeat seismic or other monitoring methods indicates a significant deviation of the AoR from the modeled forecast, seismic may be acquired at a more frequent interval. Figure 9 shows the anticipated extent of VSP imaging and notional survey design.

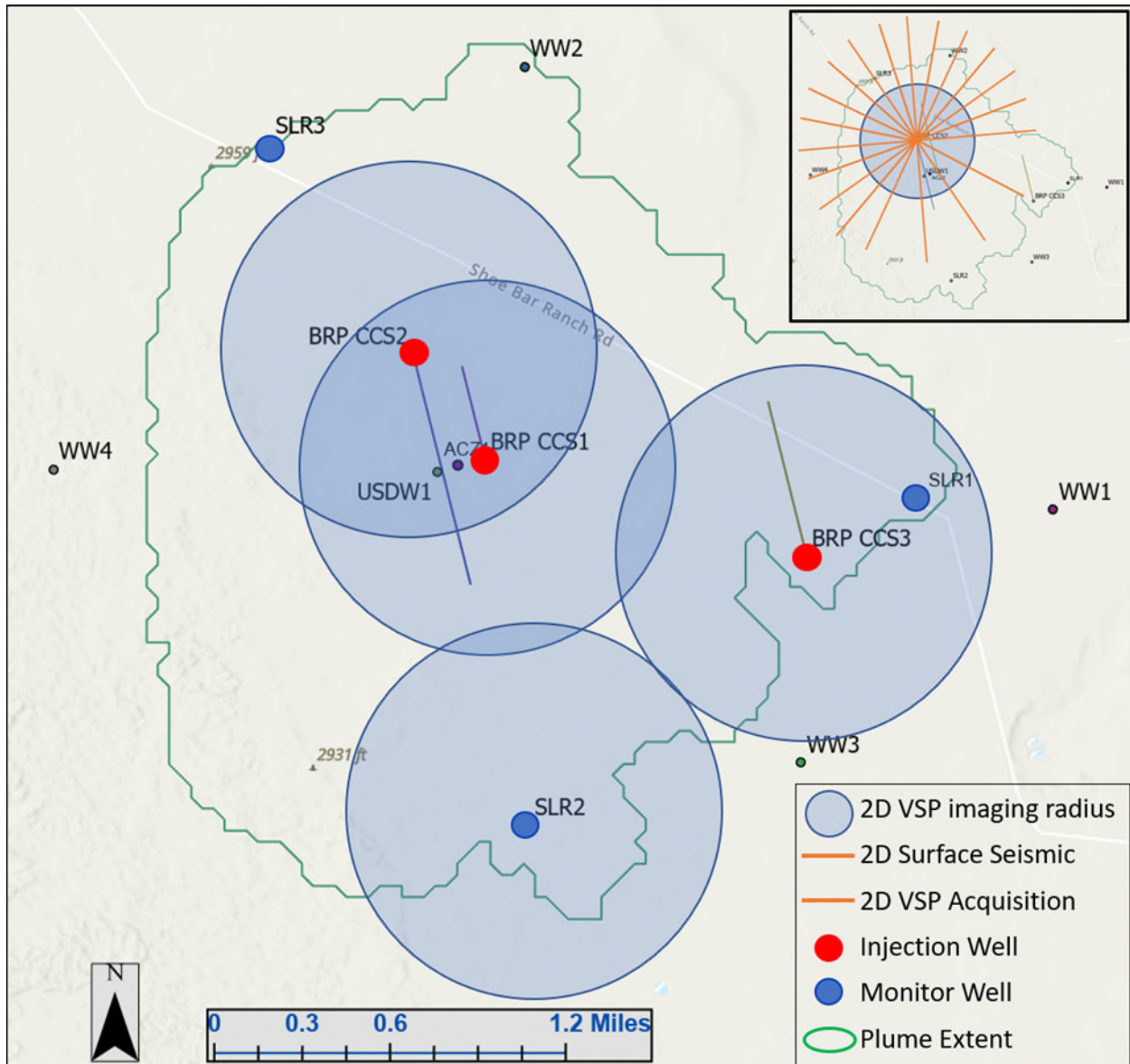

Figure 9—The extent of the 2D VSP imaging area (blue circles). The inset map shows an idealized survey design for 2D surface seismic (orange lines) with 2D VSP acquisition. The maximum distance between two open 2D lines is ~800ft for VSP and ~1,200ft for surface seismic.

New and emerging technologies

OLCV will re-evaluate new and improving time-lapse monitoring techniques, such as a Scalable, Automated, Sparse Seismic Array (SASSA), at least every five years and will recommend changes to the monitoring plan if these technologies are interpreted to provide improved monitoring results. Recommendations will be reviewed with the UIC Program Director.

11.2.3 DInSAR and GPS data acquisition

The BRP Project is using Differential Interferometric Synthetic Aperture Radar (DInSAR) and Global Positioning Systems (GPS) data to indirectly monitor the position of the AoR. DInSAR is a non-intrusive, non-destructive technology that measures, with high accuracy, relative displacement over time. It is highly effective for measuring ground deformation over multiple years. A network of 14 “corner reflectors” were installed by a third-party contractor to serve as permanent monuments to aid in data processing repeatability. Prior to CO₂ injection a historical evaluation of past ground movement will be conducted. These data will be licensed from a third-party DInSAR contractor and interpreted by the contractor and by qualified Oxy and OLCV personnel.

To further improve the resolution and accuracy of DInSAR, OLCV uses data from a network of GPS located at the corner reflectors. Data are processed by qualified Oxy or OLCV personnel or by third-party contractors.

DInSAR coupled with GPS technology provides sub-millimeter ground surface deformation data that informs the following interpretations:

- Surface impact caused by subsidence or uplift induced by Injection Zone operations;
- Calibration of geomechanical models by providing information on the mechanical properties of the Injection and Upper Confining Zone;
- Monitoring of the stress field depth; and
- Identification of potential leakage pathways.

Table 18 below describes the sampling and recording frequency for DInSAR and GPS data. See Figure 7 for the planned locations of corner reflectors.

Table 18—Summary of DInSAR and GPS sampling reviewed by the Project.

Objective	Method	Minimum sampling frequency	Minimum recording frequency
Measure surface displacement	DInSAR	Quarterly	Image recording bi-weekly
	GPS	Quarterly	Quarterly

11.2.4 Dynamic simulation modeling

A dynamic simulation model has been constructed and is used to inform the interpretation of the AoR. This model will be evaluated after the commencement of CO₂ injection operations and will be calibrated to operational data. No less frequently than every five years, OLCV will perform a

re-evaluation of the AoR [16 TAC 5.206(g)]. A determination will be made on an annual basis whether an update to the dynamic simulation model is required. The frequency of model updates will be dependent on the amount of deviation from the predicted CO₂ plume and pressure front.

Dynamic simulation modeling is used to predict changes in the Injection and Confining Zones over time. OLCV first constructed a static geocellular model using log, core, and seismic data from the site. Stratigraphic tops were selected on well logs and then mapped throughout the field to form a stratigraphic framework. The framework was divided into geologic zones and assigned rock and fluid properties derived from log and core analysis. The static geocellular model forms the basis for the reservoir simulation model.

OLCV constructed a dynamic simulation model that tracks the composition of brine and CO₂ through time. Following the commencement of injection operations, the predictions made on CO₂ and pressure front movement will be calibrated with direct and indirect plume and pressure tracking data. These data will be used to history match the dynamic model and then update forecasts of plume and pressure movement in the future. Significant deviation from forecasts will lead to updates to the AoR delineation. See additional information on delineation of the AoR in the AoR and Corrective Action Plan that is part of this application.

11.2.5 Interpretation and Analysis of Data Collected

The data collected with direct and indirect tracking methods will be evaluated by subsurface geologists and engineers. In addition, OLCV will utilize senior technical advisors to review work products and provide additional technical insight. Data will be routinely reviewed and integrated into and updated subsurface characterization that will be used to inform the AoR and future testing and monitoring plans.

12. Induced Seismicity Monitoring

12.1 Description of Methods and Justification

12.1.1 Traffic Light System for Monitoring Induced Seismicity

Based on information provided by the United States Geological Survey (USGS), the BRP Project area has low historic seismic activity. Seismicity history is discussed in more detail in the Area of Review and Corrective Action Plan document of the permit.

Change of in-situ stresses on existing faults caused by human activities (e.g., mining, dam impoundment, geothermal reservoir stimulation, wastewater injection, hydraulic fracturing, and CO₂ sequestration) may induce earthquakes on critically stressed fault segments. To monitor

potential induced seismicity due to the injection of CO₂ in the area, the Project has deployed surface seismometer stations.

OLCV intends to monitor seismicity at the Project site during the Injection and Post-injection Periods. The monitoring will be conducted with a surface array deployed to ensure detection of events above local magnitude (ML) 1.0, with epicentral locations within 10 miles of the UIC Class VI injector wells.

If an event is recorded by either the local private array or a public (national or state) array occurs within 10 miles of the UIC Class VI injector wells, OLCV will implement the response plan subject to detected earthquake magnitude limits defined below to eliminate or reduce the magnitude and/or frequency of seismic events:

- For events above ML 2.0 but below ML 3.5 within 5.6 miles of the UIC Class VI injector wells, OLCV will closely monitor seismic activity and may implement a pause to operations or continue operations at a reduced rate, should analysis indicate a causal relationship between injection operations and detected seismicity. The 5.6-mile radius is used because this is the metric used for disposal well applications to the Railroad Commission. “Pursuant to 16 Texas Administrative Code §3.9(3)(B) and §3.46(b)(1)(C), SWD well permit applications must include a review of USGS earthquake records for a circular area of 100 square miles around the proposed SWD well location (a circular area with a radius of 9.08 kilometers, or 5.64 miles).”
- For events with ML 3.5 to ML 4.5 within 5.6 miles of the UIC Class VI injector wells, OLCV will initiate contact with relevant regulatory and/or government entities. OLCV will begin a technical review within 24 hours of the event to determine if a causal relationship exists. Should a causal relationship be determined, a revised injection plan will be developed to reduce or eliminate operationally related seismicity. Such plans are dependent on the pressures and seismicity observed and may include, but not limited to:
 1. Reducing CO₂ injection pressures until reservoir pressures fall below a critical limit.
 2. Increasing water production rates until reservoir pressures fall below a critical limit
 3. Continuing operations at a reduced rate and/or below a revised maximum operation pressure.
 - o OLCV will obtain approval from the relevant regulatory and/or government entities to implement revised plan.
 - o If the event is not related to the storage facility operation, OLCV will resume normal injection rates.
- For events above ML 4.5 within 5.6 miles of the UIC Class VI injector wells, OLCV will stop injection as soon as safely practical. OLCV will inform the regulator of seismic activity and inform them that operations have stopped pending a technical analysis. OLCV

will initiate an inspection of surface infrastructure for damage from the earthquake. A detailed analysis will be conducted to determine if a causal relationship exists between injection operations and observed seismic activity. Should a causal relationship be determined, a revised injection plan would be developed to reduce or eliminate operationally related seismicity before resuming injection operations. Such plans are dependent on the pressures and seismicity observed and may include, but not be limited to:

1. Reducing injection pressures until reservoir pressures fall below a critical limit.
2. Increasing water production rates until reservoir pressures fall below a critical limit.
3. Continuing operations at a reduced rate and/or below a revised maximum operation pressure.
 - o OLCV will obtain approval from the relevant regulatory and/or government entities to implement a revised plan.
 - o If the event is not related to the storage facility operation, and with prior approval from the regulators, OLCV will adjust injection and/or production rates to previous rates in steps, while increasing the surveillance.

12.1.2 Induced Seismicity Monitoring Network

Presently, the nearest seismometers to the AoR are part of the MTX and TexNet arrays. The USGS seismometer network in Texas is known as TexNet. The MTX array is a private subscription array. Oxy has been a subscriber to MTX since its inception in 2017. Together, the data from the TexNet and MTX arrays provide accurate seismicity information throughout the Permian Basin.

OLCV installed five additional seismometers in August 2024 delivering real-time seismicity alerts within the BRP Project area. To achieve the lowest magnitude of completeness within the AOR, modeling was conducted to identify optimal locations to site the new seismometers. The data from seismometers installed for the purposes of the BRP Project are not intended to be publicly available.

A seismometer monitoring network will be deployed to determine the locations, magnitudes, and focal mechanisms of any injection-induced seismic events in case they occur. This information will be used to address public concerns and to monitor changes in induced seismicity risks with a goal of reacting to the perceived risk through adjustment of well operations as needed.

A map of Project seismometer locations is provided in Figure 10 (and also Figure 7). Existing locations are provided as attachment in the GSDT. These station locations were used for modeling the expected sensitivity of the array at the Project site.

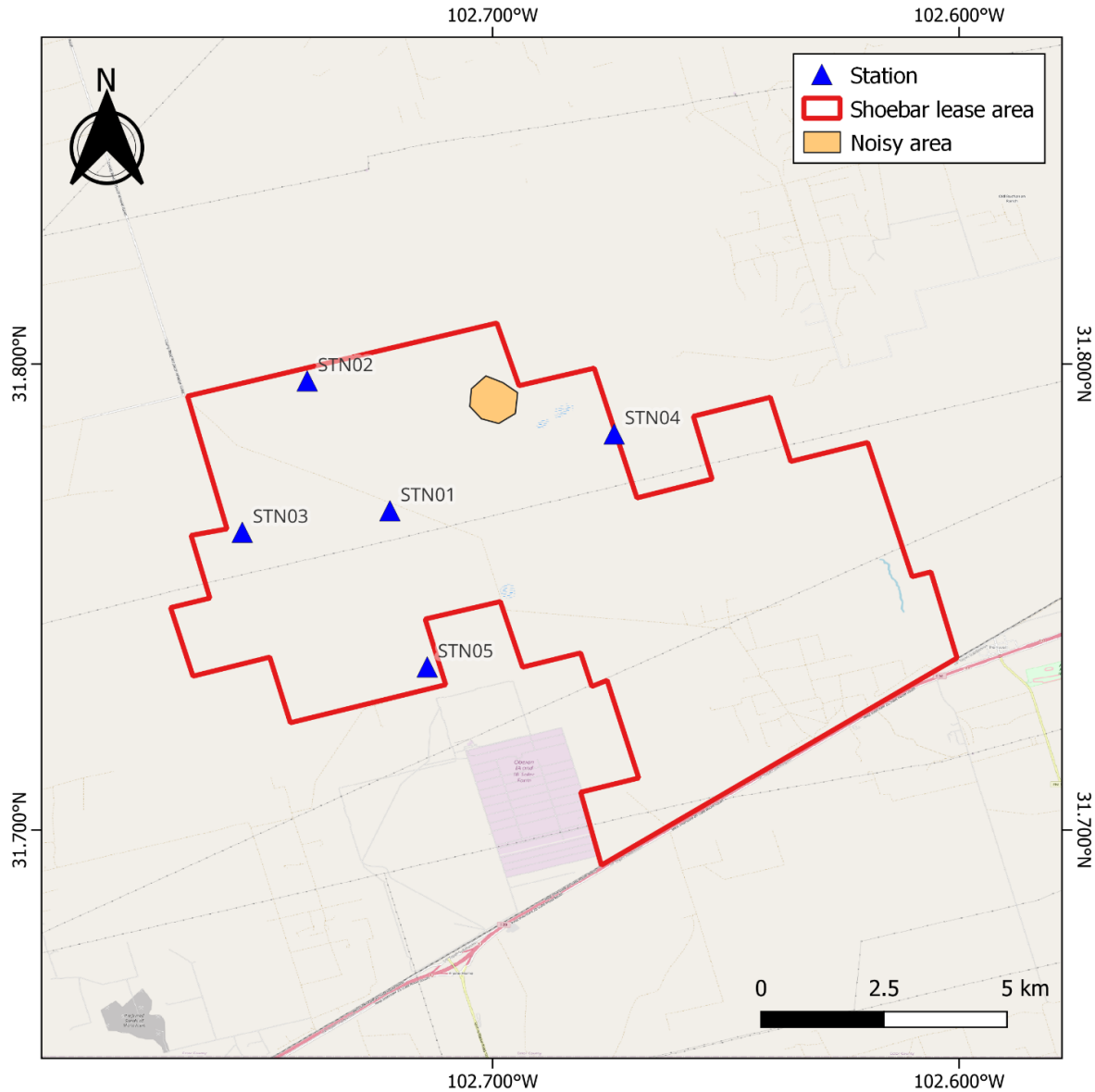

Figure 10—Locations of proposed new passive seismic monitoring stations

The design and installation of the station array was performed by specialized contractors and include the following activities:

- Project management support to design the seismometer array, model the network performance, coordinate permitting and equipment installation, conduct testing and maintenance, and ensure optimum execution of the Project.

- Field operations to deploy seismic station instrumentation, run power and communication systems, monitor data quality, and do commissioning.
- Data acquisition, system configuration, and process setup.
- Continuous support and monitoring for data verification and QA/QC.
- Continuous near-real-time reporting, including analyst reviews and alert notifications, for events at or above predetermined magnitude thresholds over the seismic area.

12.1.3 Seismicity Monitoring Equipment

The equipment utilized for seismicity monitoring includes broadband sensors, a data logger, a solar power system and backup battery, communication system, cabling, and mounting equipment (Figure 11).

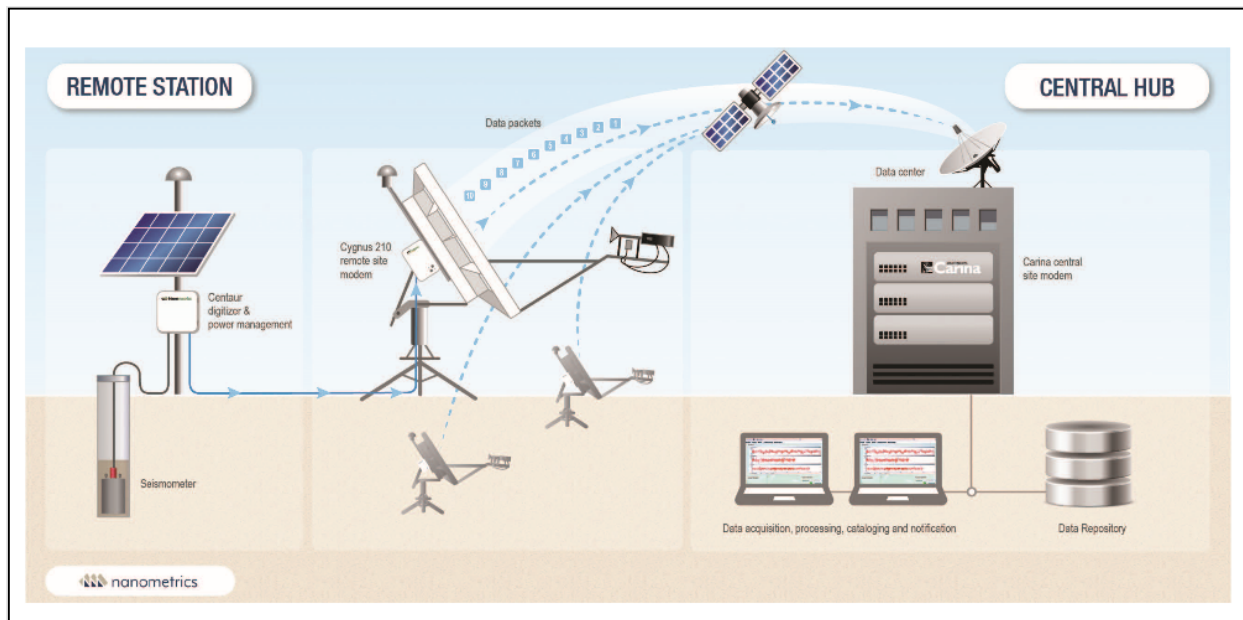

Figure 11—Example of a setup for data acquisition, transfer, storage, and analysis.

13.0 Reporting

The results of all testing and monitoring are to be described in a semi-annual and annual report that will be submitted to the RRC.

14.0 References

- Bond-Lamberty, B. and Thomson, A. 2010. Temperature-associated increases in the global soil respiration record, *Nature* 464: 579-582.
- Bourdet, D., Ayoub, J.A., and Pirard, Y.M. 1989. Use of Pressure Derivative in Well Test Interpretation. *SPE Formation Evaluation* 4:(2): 293-302. SPE-12777-PA.
- Burger, F.A., John J.G., Frolicher, T.L., 2020. Increase in ocean acidity variability and extremes under increasing atmospheric CO₂, *Biogeosciences* 17: 4633-4662.
- EPA, 2002. UIC Pressure Falloff Testing Guideline Third Revision. U.S. Environmental Protection Agency Region 6, August 2022.
- EPA, 2013. Geologic Sequestration of Carbon Dioxide Underground Injection Control (UIC) Program Class VI Well Testing and Monitoring Guidance. U.S. Environmental Protection Agency office of Water, EPA 816-R-13-001, March 2013.
- EPA, 2023a. Soil Sampling: LSASDPROC-300-R5. Region 4 U.S. Environmental Protection Agency Laboratory Services and Applied Science Division, Athens, Georgia, 22 April 2023.
- EPA, 2023b. Soil Gas Sampling: LSASDPROC-307-R5. Region 4 U.S. Environmental Protection Agency Laboratory Services and Applied Science Division, Athens, Georgia, 22 April 2023.
- Horne, R.N. 1990. *Modern Well Test Analysis: A Computer-Aided Approach*. Palo Alto, California: Petroway, Inc., 257 pp.
- Macpherson, G., Roberts, J., Blair, J., Townsend, M., Fowle, D., Beisner, K., 2008. Increasing shallow groundwater CO₂ and limestone weathering, Konza Prairie, USA, *Geochemica et Cosmochimica Acta* 72: 5581-5599.
- NETL, 2017. *Best Practices: Monitoring, Verification, and Accounting (MVA) for Geologic Storage Projects*. U.S. Department of Energy National Energy Technology Laboratory, 2017 Revised Edition. DOE/NETL-2017/1847.
- Renard, P., Glenz, D., and Mejias, M. 2009. Understanding Diagnostic Plots for Well Test Interpretation. *Hydrogeology Journal* 17: 589-600.
<https://www.nrc.gov/docs/ML1221/ML12213A523.pdf>.
- Romanak, K.D. 1997. *Vadose-Zone Geochemistry of Playa Wetlands, High Plains, Texas*. PhD Dissertation, University of Texas Libraries. <http://hdl.handle.net/2152/63279>
- Romanak, K.D., Bennett, P.C., Yang, C., et al. 2012. Process-based approach to leakage detection by vadose zone gas monitoring at geologic CO₂ storage sites. *Geophys. Res. Lett.* **39**: L15405. <http://doi.org/10.1029/2012GL052426>.

Plan revision number: 7

Plan revision date: 05/25/2026

Romanak, K.D., et al. 2014. Process-based soil gas leakage assessment at the Kerr Farm: Comparison of results to leakage proxies at ZERT and Mt. Etna. *International Journal of Greenhouse Gas Control* 30 (2014) 42-57. doi:10.1016/j.ijggc.2014.08.008

Spane, F.A. Jr. 1993. Selected Hydraulic Test Analysis Technique for Constant-Rate Discharge Test. Contract DE-ACO6-76RLO183, US DOE, Pacific Northwest Laboratory (PNL 8539), Richland, Washington (March 1993). <https://doi.org/10.2172/10154967>.

Spane, F.A. Jr. and Wurstner, S.K. 1993. DERIV: A Program for Calculating Pressure Derivatives for Use in Hydraulic Test Analysis. *Groundwater* 31(5): 814-822.

G. WELL PLUGGING PLAN

**INJECTION WELL PLUGGING PLAN
40 CFR §146.92(b)**

Brown Pelican CO₂ Sequestration Project

INJECTION WELL PLUGGING PLAN 40 CFR §146.92(b)..... 1

1.0 Facility Information and Overview..... 1

2.0 CO₂ Injection Wells 2

 2.1 Planned Tests or Measures to Determine Bottomhole Reservoir Pressure..... 2

 2.2 Planned Mechanical Integrity Test(s)..... 3

 2.3 Information on Plugs..... 6

 2.4 Plugging Schematics..... 7

3.0 Narrative Description of Plugging Procedures 12

 3.1 Notifications, Permits, and Inspections 12

 3.2 Plugging Procedures for BRP CCS1 12

 3.3 Plugging Procedures for BRP CCS2 14

 3.4 Plugging Procedures for BRP CCS3 15

1.0 Facility Information and Overview

Facility name: Brown Pelican CO₂ Sequestration Project
BRP CCS1, CCS2 and CCS3 Wells

Facility contact: 

Well location: Penwell, Texas

BRP CCS1	31.76481926	-102.72891895
BRP CCS2	31.76994887	-102.73320589
BRP CCS3	31.76024766	-102.71013484

Oxy Low Carbon Ventures, LLC (OLCV) will conduct injection well plugging and abandonment (P&A) according to the procedures contained in this document.

The UIC Class VI injection wells will be plugged and abandoned in accordance with the requirements of Environmental Protection Agency (EPA) document 40 CFR Subpart H – Criteria and Standards Applicable to Class VI Wells. The plugging procedure and materials will be designed to prevent any unwanted fluid movement, resist the corrosive aspects of carbon dioxide (CO₂) with water mixtures, and protect any underground sources of drinking water (USDWs).

Plugging procedures for UIC Class VI wells are presented in this document. Plugging plans for monitoring and water withdrawal wells are presented in Appendix A of this document.

2.0 CO₂ Injection Wells

2.1 Planned Tests or Measures to Determine Bottomhole Reservoir Pressure

1. After injection has ceased, the well will be flushed with a kill fluid. A minimum of three tubing volumes will be injected without exceeding the fracture pressure. All kill fluids that will be pumped will be 10 ppg NaCl brine.
2. Bottomhole pressure measurements will be taken using the installed downhole gauges. In case the gauges are not functioning properly, the operator will run a pressure gauge during the P&A process of the well.
3. A Temperature log will be run, and the well will be pressure tested to ensure integrity both inside and outside the casing before plugging. Production Logging Tool (PLT), tracers, and noise or active pulsed neutron logs could be run in substitution.
4. If a loss of mechanical integrity is discovered, the well will be repaired before proceeding further with the plugging operations.
5. All casing in this well will have been cemented to the surface at the time of construction and will not be retrievable at abandonment.
6. After injection is terminated permanently, the injection tubing and packer will be removed.
7. The balanced-plug placement method will be used to plug the well. A cement retainer will be used to isolate the perforated section and prevent flowback of formation fluids that could contaminate the plug.
8. All of the casing strings will be cut off at least 5 ft below the surface and plow line.
9. A blanking plate with the required permit information will be welded on top of the cutoff casing.

Any necessary revisions to the well plugging plan to address any new information collected during logging, testing, and completion of the well will be made after these activities have been

completed. The final plugging plan will be submitted to the Underground Injection Control (UIC) Program Director.

2.2 Planned Mechanical Integrity Test(s)

OLCV will conduct a temperature log and potentially additional logs listed in Table 1 and a pressure test to verify mechanical integrity before plugging the UIC Class VI injection well, as required by 40 CFR §146.92(a).

Table 1—Planned and Possible Mechanical Integrity Tests

Test Description	Location
Temperature log (External MIT)	UIC Class VI injection wells
Pulsed neutron log (External MIT)	UIC Class VI injection wells
Noise log (External MIT)	UIC Class VI injection wells
Annular Pressure Test (Internal)	UIC Class VI injection wells

The following tools are able to detect fluid movements behind the long string casing. Tools will be run on wireline. Quality assurance for the logs will be provided by the vendor at time of selection.

Temperature logs are used to locate gas entries, detect casing leaks, and evaluate fluid movement behind casing. They are also used to detect lost-circulation zones and cement placement. Temperature logs are used as a basic diagnostic tool and are usually paired with other tools like acoustics or multi arms calipers if more in depth analysis is required.

Temperature instruments used today are based on elements with resistances that vary with temperature. The variable resistance element is connected with bridge circuitry or constant current circuit, so that a voltage response proportional to temperature is obtained. The voltage signal from temperature device is then usually converted to a frequency signal transmitted to the surface, where it is converted back to a voltage signal and recorded. The absolute accuracy of temperature logging instruments is not high (in the order of +/- 5°F), but the resolution is good (0.05°F) or better, although this accuracy can be compromised by present day digitalization of the signal on the surface. The temperature instrument usually can be included in the string with other tools, such as radioactive tracer tools or spinners flowmeters. Temperature logs are run continuously, typically at cable speeds of 20 to 30 ft/min.

The following tools could be run in substitution of temperature log. They follow the same principle of detection of anomalies outside the Injection Zone.

Pulse neutron log (PNL) provides formation evaluation and reservoir monitoring in cased holes. PNL is deployed as a wireline logging tool with an electronic pulsed neutron source and one or more detectors that typically measure neutrons or gamma rays. High-speed digital signal electronics process the gamma ray response and its time of arrival relative to the start of the neutron pulse. Spectral analysis algorithms translate the gamma ray energy and time relationship into concentrations of elements. Each logging company has its own proprietary designs and improvements on the tool.

Schlumberger's Pulsar Multifunction Spectroscopy Service (PNX) pairs multiple detectors with a high output pulsed neutron generator in a slim tool with an outer diameter (OD) of 1.72 inches for through-tubing access in cased hole environments. The housing is corrosion-resistant, allowing deployment in wellbore environments such as CO₂. The tool's integration of the high neutron output and fast detection of gamma rays with proprietary pulse processing electronics, allows to differentiate and quantify gas-filled porosity from liquid-filled and tight zones. The tool can accurately determine saturation in any formation water salinity across a wide range of well conditions, mineralogy, lithology, and fluid contents profile at any inclination. Detection limits for CO₂ saturation for the PNX tool vary with the logging speed as well as the formation porosity. Detailed measurement and mechanical specifications for the PNX tool are provided in the QASP document. The wireline operator will provide QA/QC procedures and tool calibration for their equipment.

Halliburton's RMT-D reservoir monitor tool: The Halliburton Reservoir Monitor Tool 3-Detector™ (RMT-3D™) pulsed-neutron tool solves for water, oil, and gas saturations within reservoirs using three independent measurements (Sigma, C/O, and SATG). This provides the ability to uniquely solve simple or complex saturation profiles in reservoirs, while eliminating phase-saturation interdependency. The RMT-#D provides gas phase analysis to identify natural gases, nitrogen, CO₂, steam, and air. The tool has 2.125 inch OD that allows it to be run through tubing.

Pass/Fail Criteria

Well plugging is considered passed when the plugging operations meets the objective of minimizing the risk of fluid from deeper zones leaking to a USDW.

Temperature Survey

The temperature log is one of the approved logs for detecting fluid movement outside pipe. A final differential temperature survey will be run during plugging operations and will provide a final temperature curve.

The temperature will be logged from the surface to total depth in the well. Recommended line speed for the logging operations is 20 to 30 ft/minute. In general, the procedure for wireline operations will be as follows:

1. Attach a temperature probe and casing collar locator (CCL) to the wireline.
2. Begin the temperature survey. The tools will be lowered into well at 20 to 30 feet/minute, recording temperature in wellbore. The temperature survey will be run to the deepest attainable depth in the wellbore.
3. Following completion of the survey, the wireline tools will be retrieved from the wellbore.
4. A successful temperature log will “PASS” if there are no observed, unexplained anomalies outside of the Injection Zone.
5. If temperature anomalies are observed outside of the Injection Zone, additional logging may be conducted to determine whether a loss of mechanical integrity or containment has occurred. Depending on the nature of the suspected movement, radioactive tracer, noise, oxygen activation, or other logs approved by the UIC Program Director may be required to further define the nature of the fluid movement or to diagnose a potential leak.

Pressure Test

After setting the initial plug across the well completion interval / perforation, an annular pressure test (APT) will be conducted to verify internal mechanical integrity. The APT is a short-term pressure test (30 minutes) where the well is shut in and the fluid in the annulus is pressurized to a predetermined pressure and is monitored for leak off. OLCV will use a test pressure of 500 psi for the Mechanical Integrity Test (MIT). OLCV will use a 5% decrease in pressure (test pressure x .05) from the stabilized test pressure during the duration of the test to determine if the test is successful. If the annulus pressure decreases by $\geq 5\%$, the well will have failed the APT. If a well fails an APT, the test will be repeated. If the APT is again failed, the downhole equipment will be removed from the well and the source of the failure will be investigated. In general, the test procedure will be as follows:

1. Connect a high-resolution pressure transducer to the annulus casing valve and increase the annulus pressure to 500 psi and hold this pressure for 30 minutes.
2. At the conclusion of the 30-minute test the annulus pressure will be bled off to 0 psi and the pressure recording equipment will be removed from the casing valve.

Note: If a failure in the long string casing is identified, the operator will prepare a plan to repair the well before plugging and abandonment.

2.3 Information on Plugs

OLCV will use the materials and methods noted in Table 2, Table 3, and Table 4 to plug the UIC Class VI injection wells. The volume and depth of plugs reflect geology encountered during construction. Updates may be required pending the configuration of the wells at the time of plugging.

The cement(s) formulated for plugging will be compatible with CO₂. Discussion about CO₂ resistant cement selection and additive is located in the Construction Plan – Appendix B. The cement formulation and required certification documents will be submitted to the agency along with the well plugging plan. OLCV will report the wet density and will retain duplicate samples of the cement used for each plug. In plugging procedures in Section 3.0, curing time for CO₂ resistant cement is assumed to be 4 hours. The curing time for the CO₂ resistant plugs will be determined at time of operation via laboratory testing in compliance with API 10B2 (Testing of Oilwell Cements). OLCV utilizes industry recognized thresholds of 50 psi compressive strength to pressure test and 500 psi compressive strength for physically tagging. 500 psi (or greater) compressive strength will be achieved for abandonment slurries and will be reached in < 48 hours after placement. All plug mud will be 9.5-10 ppg NaCl brine with lime added at 1.0 ppb (pound per barrel) to raise the PH to >10.5 to combat corrosion, H₂S and CO₂ contamination. Xanthan gel will be added to the mud so that the viscosity is > 50 sec/qt.

Table 2—Information on Cement Plugs for BRP CCS1

Plug No.	Placement Method	Type Slurry	ID (in.)	MD Depths (ft)	Density (ppg)	Sacks	bbl
1	Squeeze plug	CO ₂ -resistant cement	4.892	4,500 to 5,600	14.8	276	64
2	Balance plug	CO ₂ -resistant cement	4.892	4,400 to 4,500	14.8	12	3
3	Balance plug	CO ₂ -resistant cement	4.892	4,000 to 4,200	14.8	24	6
4	Balance plug	CO ₂ -resistant cement	4.892	3,757 to 3,950	14.8	24	6
5	Balance plug	CO ₂ -resistant cement	4.892	2,553 to 2,653	14.8	12	3
6	Balance plug	CO ₂ -resistant cement	4.892	1,739 to 1,839	14.8	12	3
7	Balance plug	CO ₂ -resistant cement	4.892	808 to 908	14.8	12	3
8	Balance plug	CO ₂ -resistant cement	4.892	0 to 475	14.8	56	13

Notes:

- All plug depths will be reviewed and adjusted, if needed, by EPA and Texas RRC prior to commencing plugging operations.

Table 3—Information on Cement Plugs for BRP CCS2

Plug No.	Placement Method	Type Slurry	ID (in.)	MD Depths (ft)	Density (ppg)	Sacks	bbl
1	Squeeze plug	CO ₂ -resistant cement	4.892	4,390 to 5,200	14.8	208	48
2	Balance plug	CO ₂ -resistant cement	4.892	4,290 to 4,390	14.8	12	3
3	Balance plug	CO ₂ -resistant cement	4.892	3,984 to 4,184	14.8	24	6
4	Balance plug	CO ₂ -resistant cement	4.892	3,747 to 3,950	14.8	24	6
5	Balance plug	CO ₂ -resistant cement	4.892	2,556 to 2,656	14.8	12	3
6	Balance plug	CO ₂ -resistant cement	4.892	1,738 to 1,838	14.8	12	3
7	Balance plug	CO ₂ -resistant cement	4.892	815 to 915	14.8	12	3
8	Balance plug	CO ₂ -resistant cement	4.892	0 to 475	14.8	56	13

Notes:

- All plug depths will be reviewed and adjusted, if needed, by EPA and Texas RRC prior to commencing plugging operations.

Table 4—Information on Cement Plugs for BRP CCS3

Plug No.	Placement Method	Type Slurry	ID (in.)	MD Depths (ft)	Density (ppg)	Sacks	bbl
1	Squeeze plug	CO ₂ -resistant cement	4.892	4,950 to 6,150	14.8	303	70
2	Balance plug	CO ₂ -resistant cement	4.892	4,850 to 4,950	14.8	12	3
3	Balance plug	CO ₂ -resistant cement	4.892	4,244 to 4,444	14.8	24	6
4	Balance plug	CO ₂ -resistant cement	4.892	3,697 to 3,897	14.8	24	6
5	Balance plug	CO ₂ -resistant cement	4.892	2,518 to 2,618	14.8	12	3
6	Balance plug	CO ₂ -resistant cement	4.892	1,738 to 1,838	14.8	12	3
7	Balance plug	CO ₂ -resistant cement	4.892	789 to 889	14.8	12	3
8	Balance plug	CO ₂ -resistant cement	4.892	0 to 475	14.8	56	13

Notes:

- All plug depths will be reviewed and adjusted, if needed, by EPA and Texas RRC prior to commencing plugging operations.

2.4 Plugging Schematics

The proposed plugging schematic for BRP CCS1 is shown in Figure 1, the proposed plugging schematic for BRP CCS2 is shown in Figure 2 and the plugging schematic for BRP CCS3 is shown in Figure 3. A sample EPA Plugging and Abandonment Plan form is found in Figure 4.

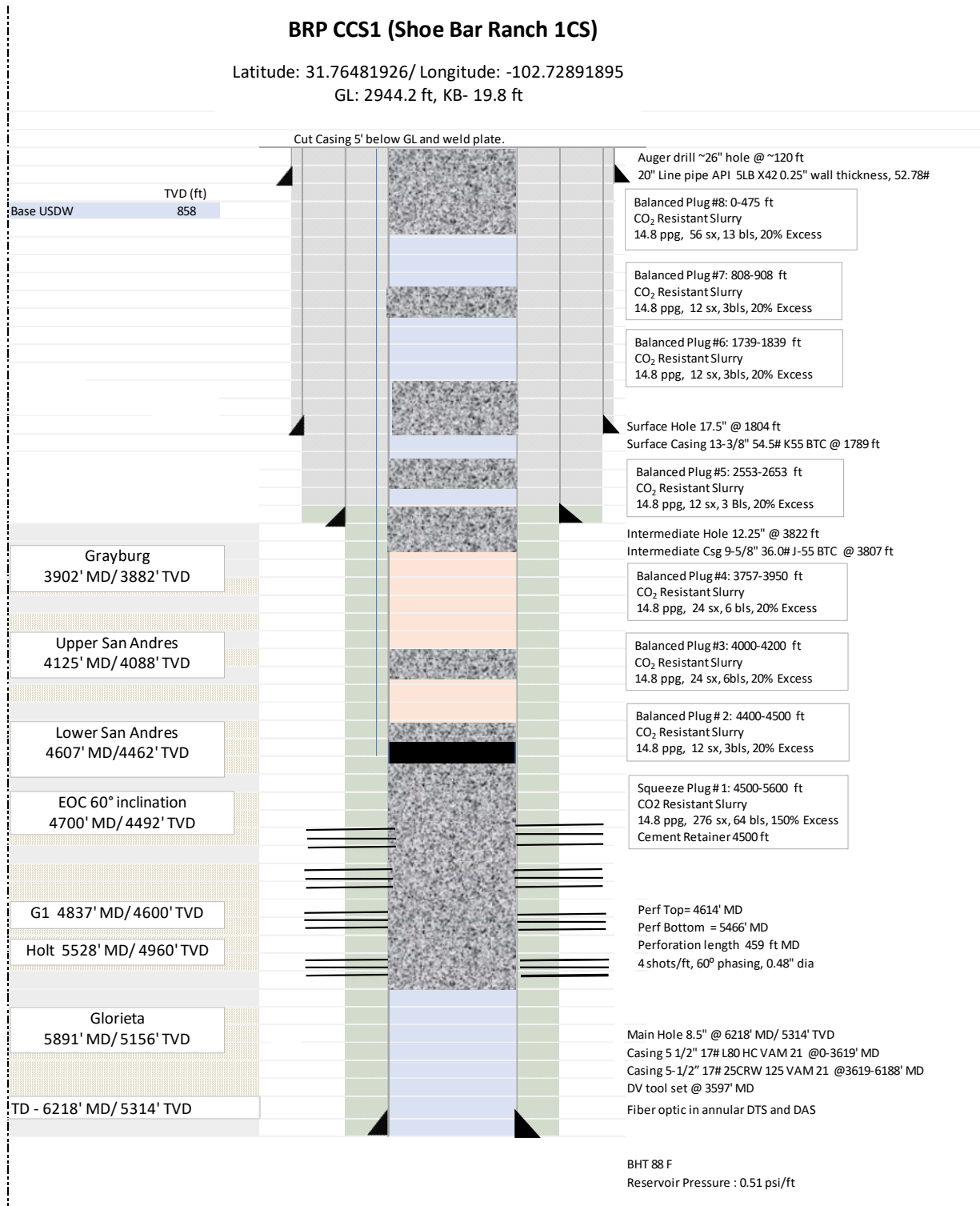

Figure 1—BRP CCS1 injection well plugging schematic

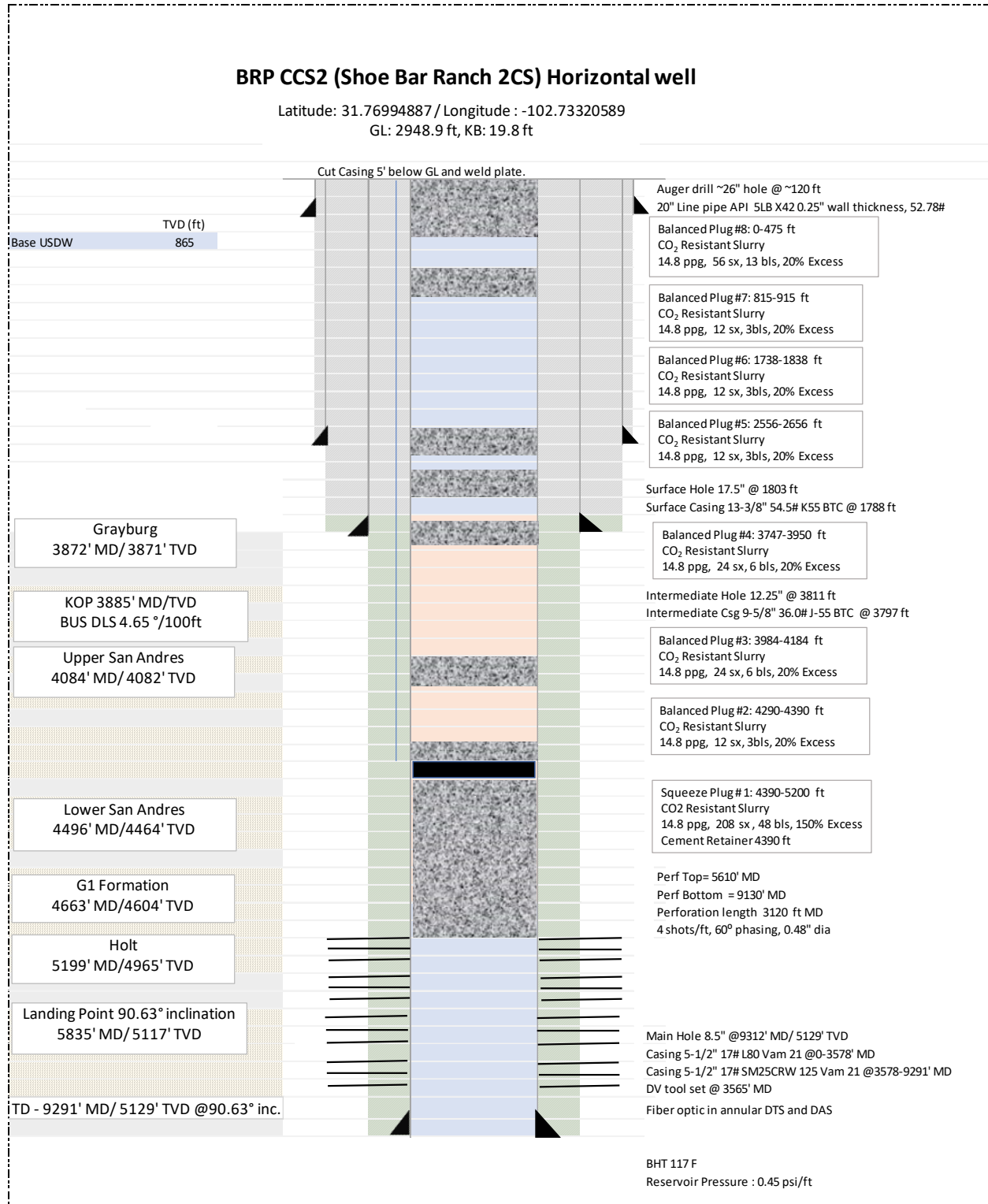

Figure 2—BRP CCS2 injection well plugging schematic

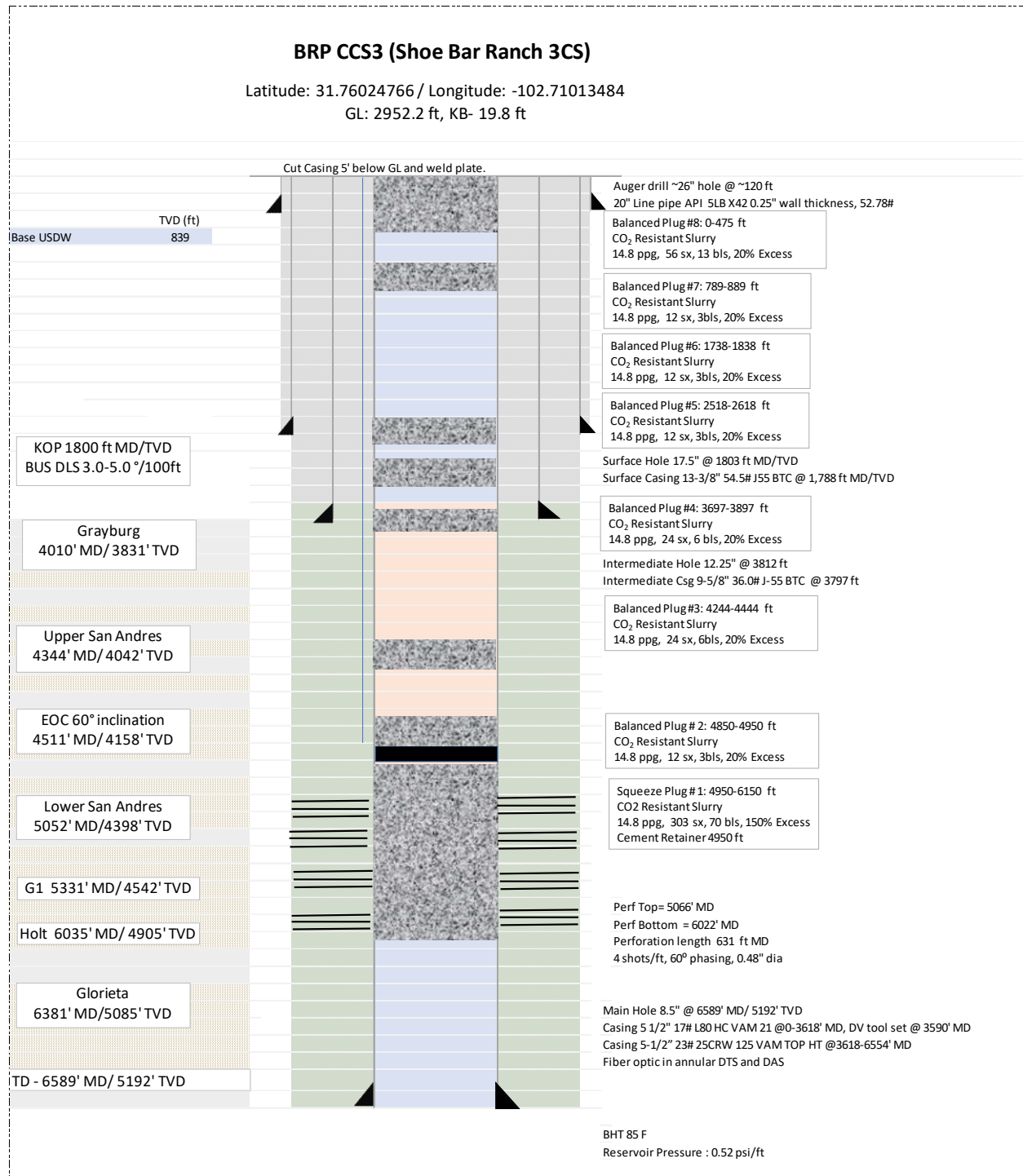

Figure 3—BRP CCS3 injection well plugging schematic

OMB No. 2040-0042 Approval Expires 11/30/2014

United States Environmental Protection Agency
Washington, DC 20460

PLUGGING AND ABANDONMENT PLAN

Name and Address of Facility
 Morgan County Class VI UIC Well #1
 (cased well completion, 1,500 ft lateral) [address not yet available]

Name and Address of Owner/Operator
 FutureGen Alliance, Inc.
 73 Central Park Plaza East, Jacksonville, IL 62650

Locate Well and Outline Unit on Section Plat - 640 Acres

State: Illinois County: Morgan Permit Number: not yet issued

Surface Location Descriptor
 SE 1/4 of SE 1/4 of SW 1/4 of SE 1/4 of Section 26 Township 16N Range 9W

Locate well in two directions from nearest lines of quarter section and drilling unit

Surface Location ft. from (N/S) Line of quarter section
 and ft. from (E/W) Line of quarter section.

TYPE OF AUTHORIZATION

Individual Permit
 Area Permit
 Rule

Number of Wells 1

Lease Name

WELL ACTIVITY

CLASS I
 CLASS II
 Brine Disposal
 Enhanced Recovery
 Hydrocarbon Storage
 CLASS III

Well Number

CASING AND TUBING RECORD AFTER PLUGGING

SIZE	WT (LB/FT)	TO BE PUT IN WELL (FT)	TO BE LEFT IN WELL (FT)	HOLE SIZE
24"	140.0	140'	140'	30"
18"	84.0	570'	570'	20"
10 3/4"	51.0	3,150'	3,150'	14 3/4"
7"	29.0	6,004'	6,004'	9 1/2"

METHOD OF EMPLACEMENT OF CEMENT PLUGS

The Balance Method
 The Dump Bailer Method
 The Two-Plug Method
 Other

CEMENTING TO PLUG AND ABANDON DATA:	PLUG #1	PLUG #2	PLUG #3	PLUG #4	PLUG #5	PLUG #6	PLUG #7
Size of Hole or Pipe in which Plug Will Be Placed (inches)	7"	7"	7"	7"	7"	7"	
Depth to Bottom of Tubing or Drill Pipe (ft)	6,004	3,900	3,100	1,800	1,500	700	
Sacks of Cement To Be Used (each plug)	451	149	0	53	0	124	
Slurry Volume To Be Pumped (cu. ft.)	505	167	271	63	167	146	
Calculated Top of Plug (ft.)	3,900	3,100	1,800	1,500	700	0 (OIL)	
Measured Top of Plug (if tagged ft.)	3,900	3,100	1,800	1,500	700	0 (OIL)	
Slurry Wt. (Lb./Gal.)	15.82	15.82	8.6	15.6	8.6	15.6	
Type Cement or Other Material (Class III)	EverCrete	EverCrete	6% Gel	Class A	6% Gel	Class A	

LIST ALL OPEN HOLE AND/OR PERFORATED INTERVALS AND INTERVALS WHERE CASING WILL BE VARIED (if any)

From	To	From	To
(7" perforated casing) 3,950 ft MD	6,004 ft MD		

Estimated Cost to Plug Wells

Plug #1 Set through a cement retainer set at 3,900 ft MD
 \$600,000.00

Certification

I certify under the penalty of law that I have personally examined and am familiar with the information submitted in this document and all attachments and that, based on my inquiry of those individuals immediately responsible for obtaining the information, I believe that the information is true, accurate, and complete. I am aware that there are significant penalties for submitting false information, including the possibility of fine and imprisonment. (Ref. 40 CFR 144.32)

Name and Official Title (Please type or print)
 Kenneth K. Humphreys, Chief Executive Officer

Signature

Date Signed
 03/03/2014

EPA Form 7520-14 (Rev. 12-11)

Figure 4—Sample EPA Plugging and Abandonment Plan form

3.0 Narrative Description of Plugging Procedures

3.1 Notifications, Permits, and Inspections

In compliance with 40 CFR §146.92(c), OLCV will notify the regulatory agency at least 60 days before plugging the well and provide an updated Injection Well Plugging Plan, if applicable.

3.2 Plugging Procedures for BRP CCS1

[REDACTED]

[REDACTED]

The procedures described above are subject to modification during execution as necessary to ensure a successful plugging operation. Any significant modifications due to unforeseen circumstances will be described in the plugging report.

3.3 Plugging Procedures for BRP CCS2

[REDACTED]

[REDACTED]

[REDACTED]

The procedures described above are subject to modification during execution as necessary to ensure a successful plugging operation. Any significant modifications due to unforeseen circumstances will be described in the plugging report.

3.4 Plugging Procedures for BRP CCS3

[REDACTED]

[REDACTED]

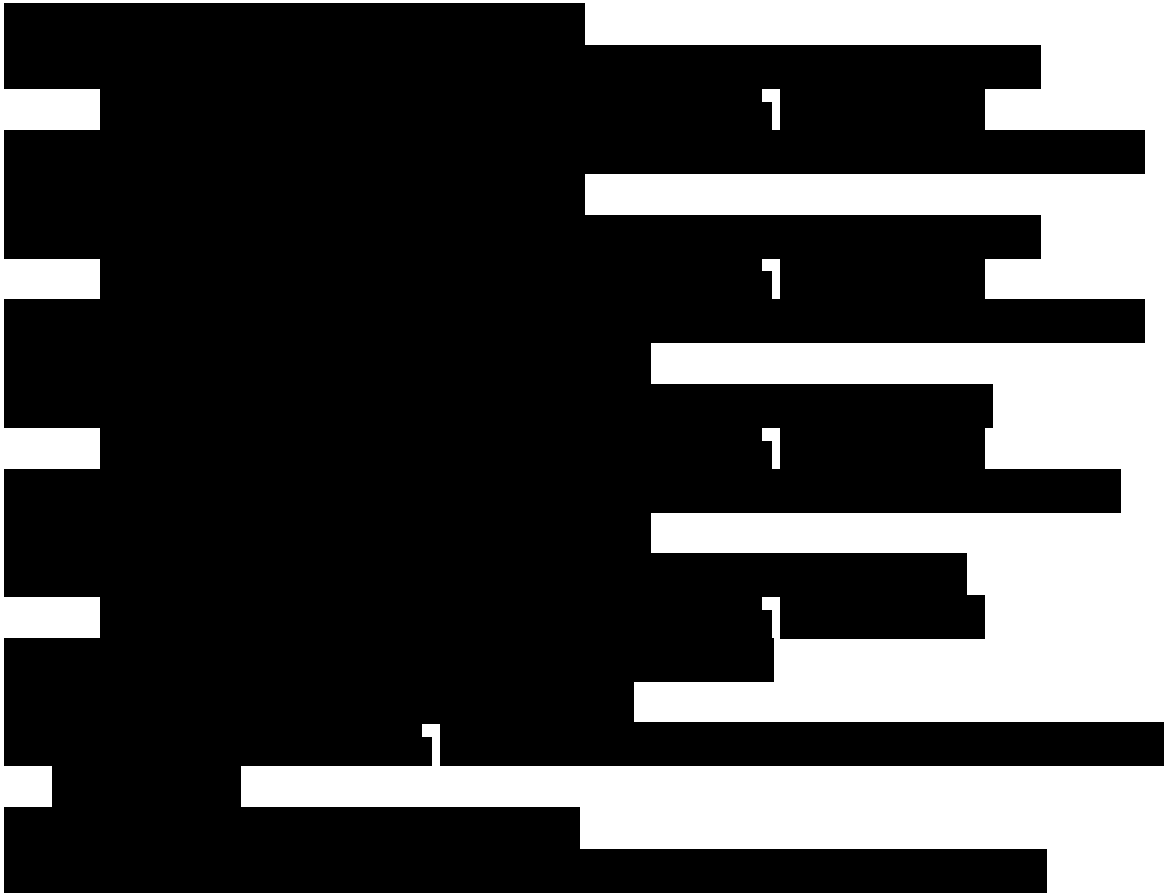

The procedures described above are subject to modification during execution as necessary to ensure a successful plugging operation. Any significant modifications due to unforeseen circumstances will be described in the plugging report.

H. EMERGENCY AND REMEDIAL RESPONSE PLAN

**EMERGENCY AND REMEDIAL RESPONSE PLAN
40 CFR §146.94(a)**

Brown Pelican CO₂ Sequestration Project

EMERGENCY AND REMEDIAL RESPONSE PLAN 40 CFR §146.94(a)..... 1

1.0 Facility Information 2

2.0 Plan Overview..... 2

3.0 Local Resources and Infrastructure 3

4.0 Potential Risk Scenarios 4

5.0 Emergency Identification and Response Actions 6

5.1 Well Control Event 6

5.2 Well Integrity Failure..... 7

5.2.1 Loss of Mechanical Integrity: Tubing or Packer Leak in Injection Well 7

5.2.2 Loss of Mechanical Integrity: Tubing or Packer Leak in Monitoring Well 8

5.2.3 Loss of Mechanical Integrity: Casing Leak in Injection Well 9

5.2.4 Loss of Mechanical Integrity: Casing Leak in Monitoring Well..... 10

5.2.5 Loss of Mechanical Integrity: Casing Leak in Water Withdrawal Well 10

5.3 Potential Brine or CO₂ Leakage to USDW..... 11

5.3.1 Vertical Migration of Brine or CO₂ to USDW: Injection Well 12

5.3.2 Vertical Migration of Brine or CO₂ to USDW: Monitoring Well 12

5.3.3 Vertical Migration of Brine or CO₂ to USDW: Water Withdrawal Well..... 13

5.3.4 Vertical Migration of Brine or CO₂ to USDW: Legacy and P&A'd Wells..... 14

5.3.5 Vertical Migration of Brine or CO₂ to USDW: Failure of Confining Rock, Faults, or Fractures..... 14

5.3.6 Lateral Migration of CO₂ to Outside the Defined AoR 15

5.4 Monitoring Equipment Failure 16

5.5 Natural Disaster 17

5.6 Induced Seismic Event..... 19

5.7 Surface Impacts..... 20

5.7.1 Loss of Containment: External Impact to Injection Wellhead..... 21

5.7.2 Loss of Containment: External Impact to Monitoring Wellhead..... 21
 5.7.3 Loss of Containment: External Impact to Water Withdrawal Wellhead 22
 5.7.4 Loss of Containment: External Impact to Surface Piping or Buried Pipeline 23
 5.7.5 Loss of Mechanical Integrity: Internal or External Corrosion on the Surface Piping
 or Buried Pipeline 24
 5.7.6 Loss of Containment: Incorrect Valve Position on the Surface Piping or Buried
 Pipeline 25
 5.7.7 Loss of Containment: CO₂ Thermal Expansion in the Injection Surface Piping or
 Buried Pipeline..... 26
 6.0 Response Personnel and Equipment 26
 7.0 Emergency Communications Plan..... 28
 8.0 Plan Review 29
 9.0 Staff Training and Exercise Procedures..... 29
 10.0 Incident Management Plan Bridging Document..... 30

1.0 Facility Information

Facility name: Brown Pelican CO₂ Sequestration Project
 BRP CCS1, CCS2 and CCS3 Wells

Facility contact: [REDACTED]
 [REDACTED]
 [REDACTED]

Well location: Penwell, Texas

BRP CCS1	31.76481926	-102.72891895
BRP CCS2	31.76994887	-102.73320589
BRP CCS3	31.76024766	-102.71013484

2.0 Plan Overview

This Emergency and Remedial Response Plan (ERRP) describes actions Oxy Low Carbon Ventures, LLC (OLCV) shall take to address movement of the injection fluid or formation fluid to prevent endangerment of an underground source of drinking water (USDW) during the construction, operation, or post-injection site care periods.

If OLCV obtains evidence that the injected CO₂ stream and/or associated pressure front may cause an endangerment to a USDW, OLCV will perform the following actions:

1. Initiate the shutdown plan for the injection well.
2. Take all steps reasonably necessary to identify and characterize any release.
3. Notify the permitting agency Underground Injection Control (UIC) Program Director of the emergency event within 24 hours.
4. Implement applicable portions of the approved ERRP.

Where the phrase “initiate shutdown plan” is used, the following protocol will be employed: OLCV will immediately cease injection. However, in some circumstances, OLCV in consultation with the UIC Program Director, will determine whether gradual cessation of injection is appropriate (using the parameters set forth in the Summary of Operating Conditions document of the Class VI permit).

3.0 Local Resources and Infrastructure

The USDWs in the vicinity of the Brown Pelican CO₂ Sequestration Project (BRP CCS or Project) that may be affected as a result of an emergency event at the project site include the Pecos Valley major aquifer and the Dockum minor aquifer. The base of the USDW in the Project area of review (AoR) is in the Dockum minor aquifer in the Santa Rosa Formation (depth range: 600 to 1,150 ft below ground level). Drainage of the Pecos Valley and Dockum aquifers from the study area is directed towards the Pecos River (30 miles SW). Figure 1 shows the surface features within the project AoR, which mainly consist of Holocene sand and silt, dunes and dune ridges, caliche, associated alluvium, and other undivided Quaternary deposits.

The Area of Review and Corrective Action Plan document provides further details on the USDWs within the project area.

Infrastructure in the vicinity of the BRP Project that may be affected as a result of an emergency at the project site includes local solar power generation operations on the surface projection of the AoR and the direct air capture (DAC) facility adjacent to the AoR.

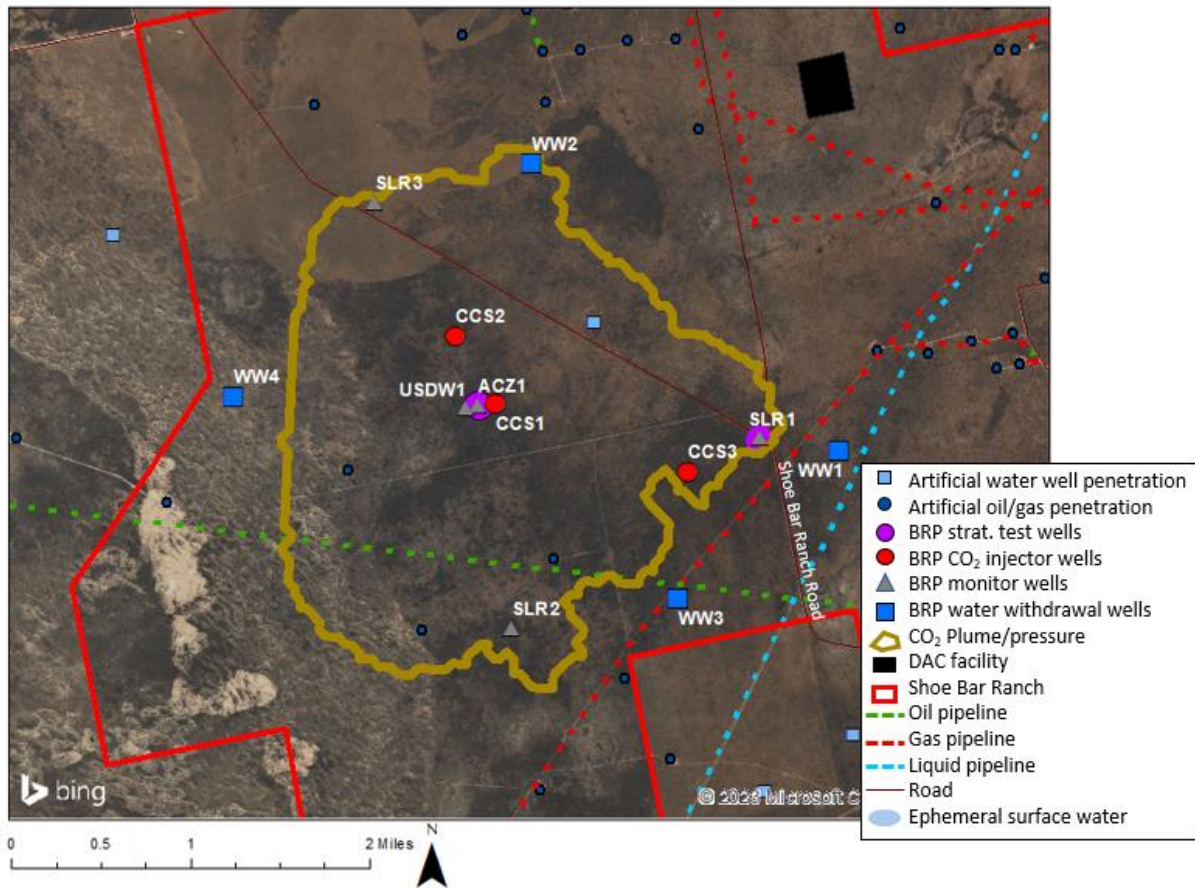

Figure 1—Map of surface features within the area of review.

4.0 Potential Risk Scenarios

The events related to the BRP Project that could potentially result in an emergency response are included in Table 1. This table lists the types of potential adverse incidents that will trigger response actions to protect USDWs if the incidents occur during the construction, injection, or post-injection site care periods. OLCV will undertake emergency or remedial actions in response to these incidents. The worst-case consequences of various scenarios have been developed to ensure that response plans are in place for all eventualities.

Table 1—Potential Emergency Events

Construction / Pre-Injection Period
<ul style="list-style-type: none"> • Well control event during drilling or completions with loss of containment
Injection Period
<ul style="list-style-type: none"> • Well integrity failure <ul style="list-style-type: none"> ○ Loss of mechanical well integrity due to tubing or packer leak in injection or monitoring well ○ Loss of mechanical well integrity due to casing leak in injection, monitoring, or water withdrawal well • Potential leakage to USDW <ul style="list-style-type: none"> ○ Vertical migration of CO₂, brines, or applicable production fluid in injection, monitoring, or water withdrawal well ○ Vertical migration of CO₂ from the Injection Zone through plugged and abandoned (P&A'd) wells in the storage complex or undocumented wells ○ Vertical migration of CO₂ from the Injection Zone through failure of the confining zone, faults, and fractures (loss of containment) ○ Lateral migration of CO₂ outside the defined AoR • Well monitoring equipment failure or malfunction (e.g., shutoff valve or pressure gauge) • A natural disaster (e.g., earthquake, tornado, hurricane, lightning strike) • Induced seismic event • Surface impacts <ul style="list-style-type: none"> ○ External impact to injection, monitoring, or water withdrawal wellhead ○ External impact to surface piping or buried pipelines ○ Loss of mechanical integrity pipeline on the surface piping or buried pipelines (e.g., internal or external corrosion) ○ Incorrect valve position leading to pipeline overpressure ○ CO₂ thermal expansion in injection pipeline
Post-Injection Site Care Period
<ul style="list-style-type: none"> • Well integrity failure <ul style="list-style-type: none"> ○ Loss of mechanical well integrity due to tubing or packer leak in monitoring well ○ Loss of mechanical well integrity due to casing leak in monitoring well • Potential leakage to USDW <ul style="list-style-type: none"> ○ Vertical migration of CO₂, brines, or applicable production fluid in monitoring well ○ Vertical migration of CO₂ from the Injection Zone through P&A'd wells in the storage complex or undocumented wells ○ Vertical migration of CO₂ from the Injection Zone through failure of the confining zone, faults, and fractures (loss of containment) ○ Lateral migration of CO₂ outside the defined AoR • Natural disaster (e.g., earthquake, tornado, lightning strike, freezing) • Induced seismic event • Surface impacts <ul style="list-style-type: none"> ○ External impact to monitoring wellhead

Response actions will depend on the severity of the event(s) triggering an emergency response. “Emergency events” are categorized as shown in Table 2.

Table 2—Risk Severity for Emergency Events

Risk Severity	Definition
Major	Emergency event poses immediate substantial risk to human health, resources, or infrastructure. Emergency actions involving local authorities (evacuation or isolation of areas) should be initiated.
Serious	Emergency event poses potential serious (or significant) near-term risk to human health, resources, or infrastructure if conditions worsen or no response actions are taken.
Minor	Emergency event poses no immediate risk to human health, resources, or infrastructure, no response action required.

5.0 Emergency Identification and Response Actions

Steps to identify and characterize the event will depend on the specific issue identified and the severity of the event. The potential risk scenarios listed in Table 1 are detailed below. OLCV will also submit a report to the Director where applicable under 40 CFR §146.91(c).

5.1 Well Control Event

Loss of containment could occur during drilling and completions operations if the hydrostatic column controlling the well decreases below the formation pressure, allowing fluids to enter the well.

Severity (residual)¹: Serious

Timing of event: Construction / Pre-Injection

Avoidance measures: Blowout prevention (BOP) equipment, kill fluid, well control training, BOP testing protocol, kick drill, lubricators for wireline operations.

Detection methods: Flow sensor, pressure sensor, tank-level indicator, tripping displacement practices, mud weight control.

Potential response actions:

- Drilling
 - Stop operation.
 - Close BOP.

¹ Residual severity accounts for consequences after implementation of avoidance measures and detection methods.

- Clear floor and secure area.
- Execute well control procedure.
- Evaluate drilling parameters and identify root cause.
- Resume operations.
- Completion
 - Stop operation.
 - Close BOP.
 - Clear floor and secure area.
 - Execute well control procedure.
 - Resume operations.

Response personnel: Rig crew and downhole (DH) contractors, rig manager, field superintendent, project manager.

5.2 Well Integrity Failure

Integrity loss of the injection well, monitoring well, and/or water withdrawal well may endanger USDWs. Integrity loss may occur during the following scenarios:

- Loss of mechanical integrity due to a tubing or packer leak in the injection well or monitoring well.
- Loss of mechanical integrity due to a casing leak in the injection well, monitoring well or water withdrawal well.

5.2.1 Loss of Mechanical Integrity: Tubing or Packer Leak in Injection Well

Loss of mechanical integrity due to a tubing or packer leak in the injection well could occur due to corrosion, damage in the tubulars during installation, packer leak (undetected), fatigue, or higher load profiles. This loss could cause a communication of the formation fluids within the annulus between the casing and tubing and sustained casing pressure. There is no loss of containment in this scenario and no movement of injection or formation fluids anticipated to endanger USDW.

Severity (residual): Minor

Timing of event: Injection

Avoidance measures: Coated tubing, inhibited packer fluid in the annulus, corrosion monitoring plan, dry CO₂ injected, trim on tubing hanger and tree, corrosion-resistant (CR) tubing tailpipes below packers, CR or Inconel[®] carrier for the sensors, new casing and tubing installed.

Detection methods: Real-time pressure and temperature gauges at the surface and downhole, electromagnetic casing inspection log, annulus pressure test, CO₂ sensor on the wellhead, distributed temperature sensing (DTS) fiber alongside production casing with real-time monitoring.

Potential response actions:

- Trigger alarm by the monitoring system or monitoring personnel.
- Follow protocol to stop operation, vent, or deviate CO₂.
- Troubleshoot the well.
- If tubing leak is detected, discuss action plan with regulating authority.
- Schedule well service to repair tubing.

Response personnel: Operations engineer, field superintendent, project manager, rig crew and DH contractors.

5.2.2 Loss of Mechanical Integrity: Tubing or Packer Leak in Monitoring Well

Loss of mechanical integrity due to a tubing or packer leak in the monitoring well could occur due to corrosion, damage in the tubulars during installation, packer leak (undetected), fatigue, or higher load profiles. This loss could cause a communication of the formation fluids within the annulus between the casing and tubing and sustained casing pressure. There is no loss of containment in this scenario and no movement of injection or formation fluids anticipated to endanger USDW.

Severity (residual): Minor

Timing of event: Injection and Post-Injection

Avoidance measures: Coated tubing, inhibited packer fluid in the annulus, corrosion monitoring plan, CR tubing tailpipes below the packer, CR or Inconel carrier for the sensors, new casing and tubing installed.

Monitoring wells are designed to be outside the projected plume for the majority of the project operation, reducing the risk of contact with CO₂.

Detection methods: Real-time pressure and temperature gauges at the surface, downhole pressure monitoring, annulus pressure test.

Potential response actions:

- Trigger alarm by the monitoring system or monitoring personnel.
- Troubleshoot the well.
- If tubing leak is detected, discuss action plan with regulating authority.

- Schedule well service to repair tubing.

Response personnel: Operations engineer, field superintendent, project manager, rig crew and DH contractors.

5.2.3 Loss of Mechanical Integrity: Casing Leak in Injection Well

Loss of mechanical integrity due to a casing leak in the injection well could occur due to corrosion, damage to the tubulars during installation, packer leak (undetected), fatigue, or higher load profiles. This loss could cause a migration of CO₂ and brines through the casing, the cement sheath, and into different formations than the injection target or into a USDW.

Severity (residual): Minor

Timing of event: Injection

Avoidance measures: CO₂-resistant cement and metallurgy (casing) across the Injection Zone, injection through tubing and packer, CR or Inconel carrier sensors, inhibited packer fluid in the annulus, cement to surface, corrosion monitoring plan, cement bond log (CBL) after installation, new casing installed.

Detection methods: Real-time pressure and temperature gauges at the surface and downhole, electromagnetic casing inspection log, CO₂ sensor on the wellhead, DTS fiber alongside production casing with real-time monitoring, flow rate monitoring, soil gas probes, neutron-activated logs, USDW water monitoring.

Potential response actions:

- Trigger alarm by the monitoring system or monitoring personnel.
- Follow protocol to stop operation, vent, or deviate CO₂.
- Troubleshoot the well.
- Evaluate if there is movement of CO₂ or brines to USDW.
- If USDW is affected, discuss remediation with regulating authority.
- If casing leak is detected, discuss action plan with regulating authority.
- Schedule well service to repair casing or plug and abandon (P&A) well based on findings of assessment.

Response personnel: Operations engineer, field superintendent, project manager, rig crew and DH contractors, remediation contractors.

5.2.4 Loss of Mechanical Integrity: Casing Leak in Monitoring Well

Loss of mechanical integrity due to a casing leak in the monitoring well could occur due to corrosion, damage in the tubulars during installation, packer leak (undetected), fatigue, or higher load profiles. This loss could cause a migration of CO₂ and brines through the casing, the cement sheath, and into different formations in the injection target or USDW.

Severity (residual): Minor

Timing of event: Injection and Post-Injection

Avoidance measures: CO₂-resistant cement, inhibited packer fluid in the annulus, CR or Inconel carrier sensors, cement to surface, corrosion monitoring plan, CBL after installation, new casing and tubing installed.

Monitoring wells are designed to be outside the projected plume for the majority of the project operation, reducing the risk of contact with CO₂.

Detection methods: Real-time pressure gauges at surface, downhole pressure monitoring, pulsed neutron logs, annulus pressure test.

Potential response actions:

- Trigger alarm by the monitoring system or monitoring personnel.
- Troubleshoot the well.
- Evaluate if there is movement of CO₂ or brines to USDW.
- If USDW is affected, discuss remediation with regulating authority.
- If casing leak is detected, discuss action plan with regulating authority.
- Schedule well service to repair casing or P&A the well based on findings of assessment.

Response personnel: Operations engineer, field superintendent, project manager, rig crew and DH contractors, remediation contractors.

5.2.5 Loss of Mechanical Integrity: Casing Leak in Water Withdrawal Well

Loss of mechanical integrity due to a casing leak in the water withdrawal well could occur due to corrosion, damage in the tubulars during installation, fatigue, or higher load profiles. This loss could cause a migration of brines through the casing, the cement sheath, and into different formations than the injection target or into a USDW.

While a water withdrawal well is down for repairs, it is unable to pull water from the reservoir to decrease pressure across the formation to allow for CO₂ injection. It is possible this would increase pressure in the formation from excess water and increase the area of review. However, multiple water withdrawal wells are included in the design of the Brown Pelican CO₂ Sequestration Project,

so the loss of one water withdrawal well would not cause significant project concerns. Multiple water wells would need to be down for pressure to increase in the formation.

Severity (residual): Minor

Timing of event: Injection

Avoidance measures: CO₂-resistant cement and metallurgy (casing) across producing zones, CO₂-resistant electrical submersible pump (ESP) equipment, cement to surface, corrosion monitoring plan, CBL after installation, new casing and tubing installed.

Detection methods: Real-time pressure and temperature gauges at the surface and downhole, electromagnetic casing inspection log, flow rate monitoring.

Potential response actions:

- Trigger alarm by the monitoring system or monitoring personnel.
- Follow protocol to stop water production.
- Troubleshoot the well.
- Evaluate if there is movement of CO₂ or brines to USDW.
- If USDW is affected, discuss remediation with regulating authority.
- If casing leak is detected, discuss action plan with regulating authority.
- Schedule well service to repair casing or P&A the well based on findings of assessment.

Response personnel: Operations engineer, field superintendent, project manager, rig crew and DH contractors, remediation contractors.

5.3 Potential Brine or CO₂ Leakage to USDW

Potential brine or CO₂ leakage to the USDW from the injection well, monitoring well, or water withdrawal well may endanger USDWs. Integrity loss may occur during the following scenarios:

- Vertical migration of CO₂ or brine between formations through the injection well, a monitoring well, or a water withdrawal well.
- Vertical migration of CO₂ or brine between formations through legacy or P&A'd wells.
- Vertical migration of CO₂ or brine between formations due to failure of the confining rock, faults, or fractures.
- Lateral migration or CO₂ outside the defined AoR.

5.3.1 Vertical Migration of Brine or CO₂ to USDW: Injection Well

Vertical migration of brine or CO₂ during injection could occur if there are induced stresses or a chemical reaction on the tubulars or cement of the injection well exposed to the CO₂ pressure or plume.

Severity (residual): Minor

Timing of event: Injection

Avoidance measures: CO₂-resistant cement and metallurgy (casing) across the Injection Zone, injection through tubing and packer, cement to surface, CBL after installation, USDW covered as section barrier with surface casing and surface cement sheath, new casing installed, corrosion monitoring plan.

Detection methods: CO₂ sensors on the wellhead, DTS fiber alongside production casing with real-time monitoring, soil gas probes, USDW water monitoring, pulsed neutron logs to be run to determine external mechanical integrity (MI), pressure gauges at the surface, flow rate monitoring, downhole pressure monitoring.

Potential response actions:

- Trigger alarm by the monitoring system or monitoring personnel.
- Follow protocol to stop operation, vent, or deviate CO₂.
- Troubleshoot the well.
- Evaluate if there is movement of CO₂ or brines to USDW.
- Discuss remediation options, action plan, and monitoring plan with regulating authority, if necessary.
- Discuss plan to repair the well with the regulating authority or P&A the well based on findings of assessment.

Response personnel: Operations engineer, field superintendent, project manager, rig crew and DH contractors, remediation contractors.

5.3.2 Vertical Migration of Brine or CO₂ to USDW: Monitoring Well

Vertical migration of brine or CO₂ during or after injection could occur if there are induced stresses or a chemical reaction on the tubulars or cement of the monitoring well exposed to the CO₂ pressure or plume.

Severity (residual): Minor

Timing of event: Injection and Post-Injection

Avoidance measures: CO₂-resistant cement across Injection Zone, CO₂-resistant metallurgy (casing) in select monitoring wells, cement to surface, CBL after installation, USDW covered as section barrier with surface casing and surface cement sheath, new casing installed, corrosion monitoring plan.

Detection methods: USDW water monitoring, pulsed neutron logs to be run for external MI, pressure gauges at surface, downhole pressure monitoring.

Potential response actions:

- Trigger alarm by the monitoring system or monitoring personnel.
- Troubleshoot the well.
- Evaluate if there is movement of CO₂ or brines to USDW.
- Discuss remediation options, action plan, and monitoring plan with regulating authority, if necessary.
- Discuss plan to repair or P&A the well with the regulating authority.

Response personnel: Operations engineer, field superintendent, project manager, rig crew and DH contractors, remediation contractors.

5.3.3 Vertical Migration of Brine or CO₂ to USDW: Water Withdrawal Well

Vertical migration of brine or CO₂ during injection could occur if there are induced stresses or a chemical reaction on the tubulars or the cement of the water withdrawal well exposed to the CO₂ pressure or plume.

Severity (residual): Minor

Timing of event: Injection

Avoidance measures: CO₂-resistant cement and metallurgy (casing) across producing zone, CO₂-resistant ESP equipment, cement to surface, CBL after installation, USDW covered as section barrier with surface casing and surface cement sheath, new casing installed, corrosion monitoring plan.

Detection methods: Real-time pressure and temperature gauges on surface and downhole, USDW water monitoring, electromagnetic casing inspection log, flowrate monitoring.

Potential response actions:

- Trigger alarm by the monitoring system or monitoring personnel.
- Follow protocol to stop water production.
- Troubleshoot the well.
- Evaluate if there is movement of CO₂ or brines to USDW.

- Discuss remediation options, action plan, and monitoring plan with regulating authority, if necessary.
- Discuss plan to repair or P&A the well with the regulating authority.

Response personnel: Operations engineer, field superintendent, project manager, rig crew and DH contractors, remediation contractors.

5.3.4 Vertical Migration of Brine or CO₂ to USDW: Legacy and P&A'd Wells

Vertical migration of brine or CO₂ during injection or post-injection could occur if there is poor cement bonding, cement degradation, or cracking in the legacy or P&A'd wells exposed to the CO₂ pressure or plume.

Severity (residual): Minor

Timing of event: Injection and Post-Injection

Avoidance measures: Legacy wells to be properly plugged and abandoned for brine movement and CO₂ plume according to the corrective action plan, injectors will be abandoned as soon as CO₂ injection in the project ends, unless they are left as monitoring wells.

Detection methods: Soil gas probes, monitoring of USDW, monitoring of injector wells that could indicate a broken seal and be causing CO₂ migration.

Potential response actions:

- Trigger alarm by the monitoring system or monitoring personnel.
- Evaluate if there is movement of CO₂ or brines to USDW due to a leak in a legacy or P&A'd well.
- Discuss remediation options, action plan, and monitoring plan with regulating authority, if necessary.
- Discuss plan to repair the well and specific remediation actions with the regulating authority.

Response personnel: Operations engineer, field superintendent, project manager, rig crew and DH contractors, remediation contractors.

5.3.5 Vertical Migration of Brine or CO₂ to USDW: Failure of Confining Rock, Faults, or Fractures

Vertical migration of brine or CO₂ during injection could occur if the pressure of the Injection Zone exceeds the sealing capacity of the caprock or seal above or if fault or fracture features are reactivated. Brine or CO₂ could leak to a shallower formation, including a USDW.

Severity (residual): Minor

Timing of event: Injection and Post-Injection

Avoidance measures: Seismic survey in the area shows no faults in the sequestration zone, injection is limited to 90% of the fracture gradient, characterization of the rocks show good sealing capacity.

Detection methods: USDW water sampling, time-lapse seismic survey, pulsed neutron logs in injection and monitoring wells, soil gas monitoring, surface pressure monitoring.

Potential response actions:

- Trigger alarm by the monitoring system or monitoring personnel.
- Follow protocol to stop CO₂ injection and/or water production.
- Assess root cause by reviewing monitoring data.
- If required, conduct geophysical survey to delineate potential leak path.
- Evaluate if there is movement of CO₂ or brines to USDW due to a failure of confining rock, faults, or fractures.
- Discuss remediation options, action plan, and monitoring plan with regulating authority, if necessary.
- Take actions to restore injection depending on nature of the leak path and the extent.

Response personnel: Monitoring staff, geologist, reservoir engineer, project manager, remediation contractors.

5.3.6 Lateral Migration of CO₂ to Outside the Defined AoR

Lateral migration of CO₂ outside the defined AoR could occur during or after injection if the plume moves faster or in an unexpected pattern and expands beyond the secure pore space and AoR for the project.

Severity (residual): Minor

Timing of event: Injection and Post-Injection

Avoidance measures: Detailed geologic model with nearby well logging as a calibration, seismic survey integrated in the model, characterization of the rocks and formation, AoR review and calibration at least every five years, monitoring of the plume until stabilization.

Detection methods: Time-lapse seismic survey, pulsed neutron logs in monitoring wells, real-time pressure and temperature gauges in monitoring wells.

Potential response actions:

- During Injection:

- Trigger alarm by the monitoring system or monitoring personnel.
 - Review monitoring data and trends compared with simulation.
 - Discuss findings with regulating authority; request to maintain injection during AoR evaluation if data show that CO₂ will stay in secured pore space.
 - Perform logging in monitoring wells.
 - Conduct geophysical survey as required to evaluate AoR.
 - Recalibrate model and simulate new AoR.
 - Assess if additional corrective actions are needed and if additional pore space is needed.
 - Assess if remediation is needed; prepare action plan and review with regulating authority.
 - Present AoR review to regulating authority for approval; adjust monitoring plan.
- Post-Injection:
 - Trigger alarm by the monitoring system, or monitoring personnel.
 - Review monitoring data and trends compared with simulation.
 - Discuss findings with regulating authority.
 - Conduct geophysical survey as required to evaluate AoR.
 - Recalibrate model and simulate new AoR.
 - Assess if additional corrective actions are needed and if additional pore space is needed.
 - Assess if remediation is needed; prepare action plan and review with regulating authority.
 - Present AoR review to regulating authority for approval; adjust monitoring plan.

Response personnel: Monitoring staff, geologist, reservoir engineer, project manager.

5.4 Monitoring Equipment Failure

The failure of monitoring equipment for wellhead pressure, temperature, and/or annulus pressure may indicate a problem with the injection well that could endanger USDWs.

Severity (residual): Minor

Timing of event: Injection

Avoidance measures: Preventative maintenance program, periodic inspections.

Detection methods: Real-time monitoring systems redundancy, field inspections.

Potential response actions:

- Trigger alarm by the monitoring system or monitoring personnel.
- Follow protocol to stop operation, vent, or deviate CO₂, if needed.
- If there is an injury or property damage, contact field superintendent and activate emergency evacuation to secure the location.
- Notify the UIC Program Director within 24 hours of the emergency event, per 40 CFR §146.91(c).
- Determine the severity of the event, based on the information available, within 24 hours of notification.
- Assess mechanical integrity of the system and propose repair actions, if necessary.
- Assess potential environmental impact and discuss remedial action with regulating authority.
- If assessment allows, discuss plan with the regulating authority to safely resume injection.
- Repair or replace instrumentation; calibrate equipment.
- Review monitoring records and, if needed, perform a falloff test to evaluate the reservoir.

Response personnel: Operations engineer, field superintendent, project manager, remediation contractors, emergency teams, geologist, reservoir engineer, monitoring staff, rig crew and DH contractors.

5.5 Natural Disaster

Well problems (integrity loss, leakage, or malfunction) may arise as a result of a natural disaster affecting the normal operation of the injection well. A major seismic event may disturb surface and/or subsurface facilities; weather-related disasters (e.g., tornado, lightning strike, or freezing) may affect surface facilities.

Severity (residual): Depending on severity of event, potentially serious

Timing of event: Injection and Post-Injection

Avoidance measures: Seismic survey of the storage complex shows no faults that could be activated in the Injection Zone, shutdown devices present on wellhead and piping to shutoff CO₂ and water production.

Detection methods: Seismometers on the surface to monitor induced seismicity will detect naturally occurring major seismic event.

Potential response actions:

- Major Seismic Event
 - For event with local magnitude level (ML) from 2.0 but below 3.5 within 5.6 miles of injection well:
 - Monitor seismic activity.
 - If needed, pause operations or make adjustments to operations at a reduced rate.
 - For event with ML from 3.5 to 4.5 within 5.6 miles of injection well:
 - Initiate contact with regulating authority regarding seismic event.
 - If needed, pause operations or make adjustments to operations at a reduced rate.
 - Review regional information and monitoring records to determine origin of the event.
 - If event is induced, re-evaluate model, define new injection parameters, and discuss with regulating authority.
 - If assessment allows for resuming injection safely, increase surveillance to validate effectiveness of actions.
 - For event above ML 4.5 within 5.6 miles of injection well:
 - Trigger alarm by the monitoring system or monitoring personnel.
 - If there are injured personnel or property damage, contact the field superintendent to activate emergency evacuation and secure the location.
 - Follow protocol to stop injection.
 - Assess mechanical integrity of the system; propose repair actions based on findings.
 - Assess environmental impact; discuss remedial action with regulating authority, if necessary.
 - Review regional information and monitoring records to determine origin of the event.
 - If event is induced, re-evaluate model, define new injection parameters, and discuss with regulating authority.
 - If assessment allows for resuming injection safely, increase surveillance to validate effectiveness of actions.

- Weather Disaster
 - Trigger alarm by the monitoring system or monitoring personnel.
 - If there are injured personnel or property damage, contact the field superintendent to activate emergency evacuation and secure the location.
 - Follow protocol to stop CO₂ injection and/or water production.
 - Assess mechanical integrity of the system; propose repair actions based on findings.
 - Assess potential environmental impact and discuss remedial action with regulating authority.
 - If assessment allows for resuming injection and/or production safely, increase surveillance to validate effectiveness of actions.

Response personnel: Operations engineer, field superintendent, project manager, geologist, reservoir engineer, monitoring staff, remediation contractors, emergency teams.

5.6 Induced Seismic Event

Based on the project operating conditions, it is highly unlikely that injection operations would ever induce a seismic event outside a 5.6-mile radius from the wellhead. Therefore, this portion of the response plan is developed for any seismic event with an epicenter within a 5.6-mile radius of the injection well. A geophone array on surface will be used to monitor the area for seismicity.

Severity (residual): Depending on severity of event; potentially serious

Timing of event: Injection and Post-Injection

Avoidance measures: Seismic survey of the storage complex shows no faults that could be reactivated, detailed geomechanical model created to evaluate whether the storage complex and region is seismically stable.

Detection methods: Geophone array on surface.

Potential response actions:

- For event with ML from 2.0 to 3.5 within 5.6 miles of injection well:
 - Monitor seismic activity.
 - If needed, pause operations or make adjustments to operations at a reduced rate.
- For event with ML from 3.5 to 4.5 within 5.6 miles of injection well:
 - Initiate contact with regulating authority regarding seismic event.
 - If needed, pause operations or make adjustments to operations at a reduced rate.

- Review regional information and monitoring records to determine origin of the event.
- If event is induced, re-evaluate model, define new injection parameters, and discuss with regulating authority.
- If assessment allows for resuming injection safely, increase surveillance to validate effectiveness of actions.
- For event above ML 4.5 within 5.6 miles of injection well:
 - Trigger alarm by the monitoring system or monitoring personnel.
 - If there are injured personnel or property damage, contact the field superintendent to activate emergency evacuation and secure the location.
 - Follow protocol to stop injection.
 - Assess mechanical integrity of the system; propose repair actions based on findings.
 - Assess environmental impact; discuss remedial action with regulating authority, if necessary.
 - Review regional information and monitoring records to determine origin of the event.
 - If event is induced, re-evaluate the model, define new injection parameters, and discuss with regulating authority.
 - If assessment allows for resuming injection safely, increase surveillance to validate effectiveness of actions.

Response personnel: Operations engineer, field superintendent, project manager, geologist, reservoir engineer, monitoring staff, remediation contractors, emergency teams.

5.7 Surface Impacts

Surface impact may cause loss of containment during the follow scenarios:

- External impact to the injection wellhead.
- External impact to the monitoring wellhead.
- External impact to the water withdrawal wellhead.
- External impact to the surface piping or buried pipelines.
- Loss of mechanical integrity due to internal or external corrosion on the surface piping or buried pipelines.
- Incorrect valve position leading to pipeline overpressure.

- CO₂ thermal expansion in the injection surface piping or buried pipelines.

5.7.1 Loss of Containment: External Impact to Injection Wellhead

External impact to the injection wellhead due to heavy trucks or equipment could cause loss of containment of brine or CO₂ if the wellhead is disconnected from the well pipe or the surface pipeline. No movement of injection or formation fluids is anticipated to endanger USDW.

Severity (residual): Serious

Timing of event: Injection

Avoidance measures: Fenced location and bollards installed, signage.

Detection methods: Real-time pressure and temperature at the wellhead and surface facilities, field inspections, optical gas imaging (OGI) cameras.

Potential response actions:

- Trigger alarm by the monitoring system or monitoring personnel.
- Automated shutdown will initiate; follow protocol to shut down CO₂ delivery if the automated shutdown devices are not functional.
- If there are injured personnel or property damage, contact the field superintendent to activate emergency evacuation and secure the location.
- Contact the field superintendent or asset manager to activate emergency plan and uncontrolled release protocol.
- Clear the location and secure the perimeter.
- Contact well control special team to execute uncontrolled release protocol that may include capping the well, drilling a relief well to kill the injector, repairing the well, or abandoning the well; discuss plan with regulating authority.
- Evaluate environmental impact to soil, water, vegetation; present remediation plan to regulating authority.
- Execute remediation and install monitoring system as needed.

Response personnel: Operations engineer, field superintendent, project manager, rig crew and DH contractors, remediation contractors, well control specialist.

5.7.2 Loss of Containment: External Impact to Monitoring Wellhead

External impact to the monitoring wellhead due to heavy trucks or equipment could cause loss of containment of brine if the wellhead is disconnected from the well pipe. No movement of injection or formation fluids is anticipated to endanger USDW.

Severity (residual): Minor

Timing of event: Injection and Post-Injection

Avoidance measures: Fenced location, bollards installed, or signage, reduced pressure in the monitoring well compared with the injection well.

Detection methods: Real-time pressure at the wellhead, field inspections.

Potential response actions:

- Trigger alarm by the monitoring system or monitoring personnel.
- If there are injured personnel or property damage, contact the field superintendent to activate emergency evacuation and secure the location.
- Contact the field superintendent or asset manager to activate emergency plan and uncontrolled release protocol.
- Clear the location and secure the perimeter. If possible, install containment devices or equipment to direct fluid away from possible sensitive areas around the location.
- Contact well control special team to execute uncontrolled release protocol that may include capping the well, drilling a relief well, repairing the well, or abandoning the well; discuss plan with regulating authority.
- Evaluate environmental impact to soil, water, and vegetation; present remediation plan to regulating authority.
- Execute remediation and install monitoring system as needed.

Response personnel: Operations engineer, field superintendent, project manager, rig crew and DH contractors, remediation contractors, well control specialist.

5.7.3 Loss of Containment: External Impact to Water Withdrawal Wellhead

External impact to the water withdrawal wellhead due to heavy trucks or equipment could cause loss of containment of brine if the wellhead is disconnected from the well pipe or the surface pipeline. No movement of injection or formation fluids is anticipated to endanger USDW.

Severity (residual): Minor

Timing of event: Injection

Avoidance measures: Fenced location, bollards installed, or signage.

Detection methods: Real-time pressure and temperature monitoring at surface and downhole, field inspections.

Potential response actions:

- Trigger alarm by the monitoring system or monitoring personnel.
- Automated shutdown will initiate; follow protocol to shut down water withdrawal if the automated shutdown devices are not functional.
- If there are injured personnel or property damage, contact the field superintendent to activate emergency evacuation and secure the location.
- Contact the field superintendent or asset manager to activate the emergency plan and uncontrolled release protocol.
- Clear the location and secure the perimeter. If possible, install containment devices or equipment to direct fluid away from possible sensitive areas around the location.
- Contact well control special team to execute uncontrolled release protocol that may include capping the well, drilling a relief well, repairing the well, or abandoning the well; discuss plan with regulating authority.
- Evaluate environmental impact to soil, water, and vegetation; present remediation plan to regulating authority.
- Execute remediation and install monitoring system as needed.

Response personnel: Operations engineer, field superintendent, project manager, rig crew and DH contractors, remediation contractors, well control specialist.

5.7.4 Loss of Containment: External Impact to Surface Piping or Buried Pipeline

External impact to the surface piping or buried pipeline due to heavy trucks or equipment could cause loss of containment of brine or CO₂ if the pipe ruptures. No movement of injection or formation fluids is anticipated to endanger USDW.

Severity (residual): Serious

Timing of event: Injection

Avoidance measures: Fenced location, bollards, or signage installed; and, One Call 811 program.

Detection methods: Real-time pressure, temperature, and flow measurement; field inspections.

Potential response actions:

- Trigger alarm by the system or operations staff.
- Automated shutdown will initiate; follow protocol to shut down CO₂ delivery or water withdrawal if the automated shutdown devices are not functional.
- If there are injured personnel or property damage, contact the field superintendent to activate emergency evacuation and secure the location.

- Clear the location and secure the perimeter. If possible, for water withdrawal pipelines, install containment devices or equipment to direct fluid away from possible sensitive areas around the location.
- Assess mechanical integrity of the system and propose repair actions based on the findings.
- Evaluate environmental impact to soil, water, vegetation; present remediation plan to the regulating authority.
- Execute remediation and install monitoring system as needed.

Response personnel: Operations engineer, field superintendent, project manager, remediation contractors, plant manager, HSE representatives.

5.7.5 Loss of Mechanical Integrity: Internal or External Corrosion on the Surface Piping or Buried Pipeline

Loss of mechanical integrity due to internal or external corrosion in the injection pipeline or water withdrawal pipeline could cause loss of containment of brine or CO₂ if a leak develops. No movement of injection or formation fluids anticipated to endanger USDW.

Severity (residual): Serious

Timing of event: Injection

Avoidance measures: Application of asset integrity / mechanical integrity (AI/MI) program, use of lined pipe, as appropriate.

Detection methods: Real-time pressure, temperature, and flow measurement, field inspections.

Potential response actions:

- Trigger alarm by the system or operations staff.
- Automated shutdown will initiate; follow protocol to shut down CO₂ delivery or water withdrawal if the automated shutdown devices are not functional.
- If there are injured personnel or property damage, contact the field superintendent to activate emergency evacuation and secure the location.
- Clear the location and secure the perimeter. If possible, for water withdrawal pipelines, install containment devices or equipment to direct fluid away from possible sensitive areas around the location.
- Assess mechanical integrity of the system and propose repair actions based on the findings.
- Evaluate environmental impact to soil, water, vegetation; present remediation plan to regulating authority.
- Execute remediation and install monitoring system as needed.

Response personnel: Operations engineer, field superintendent, project manager, remediation contractors, plant manager, HSE representatives.

5.7.6 Loss of Containment: Incorrect Valve Position on the Surface Piping or Buried Pipeline

An incorrect valve position within the injection or production piping network could lead to high pressure within the piping and possible loss of containment of brine or CO₂ if the pipe ruptures. No movement of injection or formation fluids anticipated to endanger USDW.

Severity (residual): Serious

Timing of event: Injection

Avoidance measures: Relief valve located on pipeline at CO₂ injection wellhead, pipeline pressure rating exceeds max compressor or pump discharge pressure.

Detection methods: Real-time pressure monitoring with automatic shutdown, pressure monitoring in control room with operator response.

Potential response actions:

- Trigger alarm by the system or operations staff.
- Automated shutdown will initiate; follow protocol to shut down CO₂ delivery or water withdrawal if the automated shutdown devices are not functional.
- If there are injured personnel or property damage, contact the field superintendent to activate emergency evacuation and secure the location.
- Clear the location and secure the perimeter. If possible, for water withdrawal pipelines, install containment devices or equipment to direct fluid away from possible sensitive areas around the location.
- Assess the mechanical integrity of the system and propose repair actions based on the findings.
- Evaluate environmental impact to soil, water, and vegetation; present remediation plan to regulating authority.
- Execute remediation and install monitoring system as needed.

Response personnel: Operations engineer, field superintendent, project manager, remediation contractors, plant manager, HSE representatives

5.7.7 Loss of Containment: CO₂ Thermal Expansion in the Injection Surface Piping or Buried Pipeline

High-pressure CO₂ has the potential for thermal expansion when exposed to high temperatures and could lead to loss of containment of CO₂ if the pipe ruptures. No movement of injection or formation fluids anticipated to endanger USDW.

Severity (residual): Serious

Timing of event: Injection

Avoidance measures: Relief valve located on the pipeline at the CO₂ injection wellhead, thermal relief valve, pipeline pressure rating exceeds maximum compressor discharge pressure.

Detection methods: Real-time pressure monitoring with automatic shutdown, pressure monitoring in control room with operator response.

Potential response actions:

- Trigger alarm by the system or operations staff.
- Automated shutdown will initiate; follow protocol to shut down CO₂ delivery if the automated shutdown devices are not functional.
- If there are injured personnel or property damage, contact the field superintendent to activate emergency evacuation and secure the location.
- Clear the location and secure the perimeter.
- Assess mechanical integrity of the system and propose repair actions based on the findings.
- Evaluate environmental impact to soil, water, and vegetation; present remediation plan to the regulating authority.
- Execute remediation and install monitoring system as needed.

Response personnel: Operations engineer, field superintendent, project manager, remediation contractors, plant manager, HSE representatives.

6.0 Response Personnel and Equipment

Site personnel, project personnel, and local authorities will be relied upon to implement the ERRP.

Monitoring, control, and routine maintenance of the injection operations will be the responsibility of the Injection Operations Staff. Site personnel are expected to include, at a minimum, the positions listed below in Table 3.

If an adverse event is discovered, the Operations Manager and Emergency Coordinator on duty will be notified immediately. The Emergency Coordinator will be responsible for notifying offsite emergency agencies and resources. The Operations Manager will contact outside emergency

response organizations if the Emergency Coordinator is not available. The EPA Region 6 UIC Program Director will also be notified within 24 hours.

Table 3–Operations Staff Descriptions

Position	Function	Qualifications
Emergency Coordinator	Responsible for notification of offsite support agencies in accordance with written procedures. Responsible for coordination and overseeing contact with the media.	Trained in the Communications Plan and Emergency Notification Procedures requirements as contained in the ERRP.
Operations Manager	Serves as the Emergency Response Manager responsible for the overall management of the Incident Response Team. Manages facility operations and personnel during an emergency and is responsible for implementation of appropriate emergency procedures and their follow-up activities.	Trained in the requirements of the ERRP and facility operations.
Project Manager	Serves as the Emergency Response Coordinator responsible for the overall communication between Incident Response Team members. Directs facility operations during an emergency and is responsible for communication between on-site personnel and professional services. Implements emergency procedures and ensures documentation of follow-up activities.	Trained in the requirements of the ERRP and facility operations.
Reservoir Engineer	Responsible for injection operation and monitoring. Lead incident response manager regarding injection and storage zone operation at the facility.	Undergraduate degree in engineering, related to chemical or reservoir engineering.
Geologist/ Geophysicist	Professional serving to assist in operation, maintenance, and monitoring of the injection process. Conducts routine data management and interpretation. Assists in implementing response actions regarding Injection Zone integrity.	Undergraduate degree in geophysics or geology with specialization in hydrology/fluid mechanics.
Operations Engineer	Oversees mechanical and fluid management operation of the injection wells, annulus pressure control system, and wellhead piping systems. Maintains and repairs injection-related equipment, including valves, instruments, and piping. Assists in mechanical and electronic control of the injection process.	Undergraduate degree in engineering related to mechanical, chemical, or process control.

A site-specific emergency contact list will be developed and maintained during the life of the project. OLCV will provide the current site-specific emergency contact list to the UIC Program Director.

A list of contacts for state agencies having jurisdiction within the AoR and key local emergency agencies is presented below in Table 4.

There are no federally recognized Native American Tribes located within the AoR. If a federally recognized Native American Tribe were to exist in the AoR at the time of a site emergency, then that tribe(s) will be notified of the site emergency at that time.

Table 4–Contact Information for Key Local, State, and Other Authorities

Agency	Location	Phone
West Odessa Volunteer Fire Department	West Odessa, TX	911 or 432-381-2305
Odessa Fire Rescue	Odessa, TX	911 or 432-257-0502
Goldsmith Volunteer Fire Department	Goldsmith, TX	432-631-2749
Odessa Police Department	Odessa, TX	911 or 432-333-3641
Odessa Regional Medical Center	Odessa, TX	432-582-8000
Odessa Medical Center Hospital	Odessa, TX	432-640-4000
Highway Patrol	Odessa, TX	432-332-6100
Ector County Sheriff	Odessa, TX	432-335-3050
Texas Division of Emergency Management	Austin, TX	512-424-2208
Ector County Office of Emergency Management	Odessa, TX	432-498-4025
US EPA Region 6 Director	Dallas, TX	214-665-6647
Railroad Commission of Texas Emergency Hotline	Austin, TX	512-463-6788 or 844-773-0305

Equipment needed in the event of an emergency and remedial response will vary, depending on the triggering emergency event. Response actions (cessation of injection, well shut-in, and evacuation) will generally not require specialized equipment to implement. Where specialized equipment (such as a drilling rig or logging equipment) is required, OLCV shall be responsible for its procurement.

7.0 Emergency Communications Plan

OLCV will communicate to the public about any event that requires an emergency response to ensure that the public understands what happened and whether there are any environmental or safety implications. The amount of information, timing, and communications method(s) will be appropriate to the event, its severity, whether any impacts to drinking water or other environmental resources occurred, any impacts to the surrounding community, and their awareness of the event.

OLCV will describe what happened, impacts to the environment or other local resources, how the event was investigated, what response actions were taken, and the status of the response. For responses that occur over the long term (e.g., ongoing cleanups), OLCV will provide periodic updates on the progress of the response action(s).

OLCV will communicate with entities who need to be informed about or take action in response to the event, including local water systems, CO₂ source(s), pipeline operators, landowners, and regional response teams (as part of the National Response Team).

If a seismic event occurs, OLCV will provide information about whether the event was naturally occurring or induced by the injection, whether any damage to the well or other structures in the area occurred, the investigative process, and what responses, if any, were taken by OLCV or others.

8.0 Plan Review

This ERRP shall be reviewed:

- At least once every five (5) years following its approval by the permitting agency;
- Within one (1) year of an area of review (AOR) re-evaluation;
- Within a prescribed period (to be determined by the permitting agency) following any significant changes to the injection process or the injection facility, or an emergency event; or
- As required by the permitting agency.

If the review indicates that no amendments to the ERRP are necessary, OLCV will provide the permitting agency with the documentation supporting the “no amendment necessary” determination.

If the review indicates that amendments to the ERRP are necessary, amendments shall be made and submitted to the permitting agency within six months following an event that initiates the ERRP review procedure.

9.0 Staff Training and Exercise Procedures

All operations employees will receive training related to health and safety, operational procedures, and emergency response according to the roles and responsibilities of their work assignments. Initial training will be conducted by, or under the supervision of, the operations manager or a designated representative. Trainers will be thoroughly familiar with the Operations Plan and ERRP.

Facility personnel will participate in annual training that teaches them to perform their duties in ways that prevent CO₂ discharge. The training will include familiarization with operating procedures and equipment configurations appropriate to the job assignment as well as emergency

response procedures, equipment, and instrumentation. New personnel will be instructed before beginning their work.

Refresher training will be conducted at least annually for all operations personnel. Monthly briefings will be provided to operations personnel according to their respective responsibilities and will highlight recent operating incidents, actual experience in operating equipment, and recent storage reservoir monitoring information.

Only personnel who have been properly trained will participate in drilling, construction, operations, and equipment repair at the storage site. A record including the person's name, date of training, and instructor's signature will be maintained.

10.0 Incident Management Plan

The information below describes the response plan for addressing a potential Health, Safety, Environment (HSE) event at the Brown Pelican Project. This document is stored in a digital repository accessible to all Project employees and updated as needed.



Brown Pelican (Shoebar Ranch) Incident Management Plan Bridging

Business Unit	Odessa Asset (EOR), Bravo Pipeline (Prod Ops), Major Projects, OxyChem
Assets	Shoe Bar Ranch CCS, Stratos DAC Plant, Bravo Pipelines
Counties	Ector

Responsibilities

OxyChem: Responsible for operations of direct air capture facilities

Bravo Pipeline (Prod Ops): Responsible for operation of regulated pipelines

Odessa Asset (EOR BU): Responsible for operations of Injection wells and injection facilities

Major Projects: Responsible for construction of direct air capture facilities

Responding to HSE Events

- a. Perform a site evaluation and evacuation of all personnel to a muster point or other safe location
- b. Identify and notify the party responsible (Bravo Pipeline, Odessa Asset, Major Projects, SBR Leadership Team, OxyChem, Swift Air Solar, and 3rd party pipelines)
 - Bravo Pipeline: Notify Pipeline Control Center
 - Odessa Asset: Notify EOR Call Center
 - OxyChem: Notify Stratos Control Room
 - Major Projects: Notify Stratos Control Room
 - Swift Air Solar: Notify Plant Manager
 - 3rd party pipelines: Contact emergency numbers
- c. The control center that was notified will contact affected parties to take appropriate action
- d. Contact emergency services, if required
 - Preferred that 911 call come from someone on-site
 - Appropriate control center shall be given as a secondary call-back number
- e. Remain on-site and assist with accountability, site security, and information gathering until responsible party personnel arrive at the location.
 - Upon their arrival, transfer all information and the scene to them
 - Can remain on-site to continue support at their discretion
- f. The party responsible will follow their incident management plan
- g. In the case of emergency, SBR Leadership team will call RRC Emergency Number and EPA Region 6 within 24 hours of the event

Leadership Communication

- a. Communications for the incident will include all affected parties
- b. The lead for the party responsible will establish primary communications
 - Initial notifications may include phone calls and text messages
 - An email including appropriate leadership will be established as soon as reasonably possible

Document Approvers:

Odessa Asset: _____

Major Projects: _____

Bravo Pipeline: _____

OxyChem: _____



Shoe Bar Ranch Emergency Call Out Reference

IN CASE OF EMERGENCY CALL: 911

NOTIFY APPROPRIATE CALL CENTER OF ALL INCIDENTS IMMEDIATELY

**Stratos Plant:
361-548-4514 (TBD)**

**Bravo Pipeline
1-800-519-8225**

**Injection Facilities
1-800-532-2587**

**Stratos: 14991 S. Wheeler Rd
Notrees, TX 79759**

**Stratos GPS Coordinates: Latitude: 31.9842
Longitude: -102.7832**

Emergency Services	Non-Emergency Number	Address
Fire/EMS: Odessa Fire Rescue	432-257-0502	1100 W 2nd St, Odessa, TX
Fire: Goldsmith VFD	432-631-2749	216 N Scharbauer St, Goldsmith, TX
Fire: West Odessa VFD	432-934-2305	2757 N Tripp Ave, Odessa, TX
Sheriff: Ector County Sheriff's	432-335-3050	2500 South US Highway 385 Odessa, TX
Hospital: Odessa Regional	432-582-4000	520 E 6th St, Odessa, TX
Helicopter: AeroCare	1-800-627-2376	Odessa, TX

3rd Party Pipelines	Type	Phone
Centurion Pipeline (Energy Transfer)	Emergency contact	1-800-765-8695
Crestwood Midstream (Energy Transfer)	Emergency contact	1-800-375-5702
DCP Midstream (Phillips 66)	Emergency contact	1-888-204-1781
Phillips 66	Emergency contact	1-877-267-2290
Tenaz Energy – (Note: this pipeline is listed as “Abandoned” in Rextag)	Emergency contact	1-888-293-6174
Enterprise Products	Emergency contact	1-888-883-6308
ETS Permian (Enterprise Products)		1-800-753-5531
ONEOK Westex Transmission	Emergency contact	1-800-562-5879
Centurion Pipeline (Energy Transfer)	Emergency contact	1-800-765-8695
Crestwood Midstream (Energy Transfer)	Emergency contact	1-800-375-5702
DCP Midstream (Phillips 66)	Emergency contact	1-888-204-1781
Regulatory		
RRC Emergency Hotline	Emergency hotline	512-463-6788 or 844-773-0305
EPA Region 6 Director	Troy Hill	214-665-6647

I. POST INJECTION SITE CARE AND SITE CLOSURE PLAN

POST-INJECTION SITE CARE AND SITE CLOSURE PLAN
40 CFR §146.93(a)

Brown Pelican CO₂ Sequestration Project

1.0 Facility Information	2
2.0 Plan Overview.....	2
3.0 Pre- and Post-Injection Pressure Differential [40 CFR §146.93(a)(2)(i)]	2
4.0 Predicted Position of the CO ₂ Plume and Associated Pressure Front at Site Closure [40 CFR §146.93(a)(2)(ii)]	9
5.0 Post-Injection Monitoring Plan [40 CFR §146.93(b)(1)]	15
5.1 Monitoring Above the Upper Confining Zone	16
5.2 Carbon Dioxide Plume and Pressure Front Tracking [40 CFR §146.93(a)(2)(iii)]	17
5.3 Schedule for Submitting Post-Injection Monitoring Results [40 CFR §146.93(a)(2)(iv)]	19
6.0 Non-Endangerment Demonstration Criteria	19
6.1 Introduction and Overview	19
6.2 Summary of Existing Monitoring Data.....	20
6.3 Summary of Computational Modeling History	20
6.4 Evaluation of Reservoir Pressure	20
6.5 Evaluation of Carbon Dioxide Plume	21
6.6 Evaluation of Emergencies or Other Events	21
7.0 Site Closure Plan.....	22
7.1 Plugging Monitoring Wells.....	22
7.2 Site Closure Report	23

Plan Revision number: 3
Plan revision date: 07/30/2024

1.0 Facility Information

Facility name: Brown Pelican CO₂ Sequestration Project
BRP CCS1, BRP CCS2 and BRP CCS3 Wells

Facility contact:



Well locations: Penwell, Texas

BRP CCS1	31.76479314	-102.7289311
BRP CCS2	31.76993805	-102.7332448
BRP CCS3	31.76031163	-102.7101566

2.0 Plan Overview

This Post-Injection Site Care and Site Closure (PISC) plan describes the activities that Oxy Low Carbon Ventures, LLC (OLCV) will perform on the Brown Pelican CO₂ Sequestration Project (BRP Project or Project) to meet the requirements of 40 CFR §146.93. OLCV will monitor groundwater quality and track the position of the CO₂ plume and pressure front for 50 years or for the duration of an alternative timeframe approved by the UIC Program Director pursuant to the requirements of 40 CFR §146.93(c) unless OLCV makes a demonstration under 40 CFR §146.93(b)(2) that OLCV has substantial evidence that the geologic sequestration project no longer poses a risk of endangerment to Underground Sources of Drinking Water (USDWs). Pursuant to 40 CFR §146.93(b)(3), OLCV will continue post-injection site care until the UIC Program Director approves a demonstration that no additional monitoring is needed to ensure non-endangerment of USDWs. Following approval for site closure, OLCV will plug all remaining monitoring wells and submit a site closure report and associated documentation.

3.0 Pre- and Post-Injection Pressure Differential [40 CFR §146.93(a)(2)(i)]

Based on modeling the pressure front as part of the Area of Review (AoR) delineation, the maximum predicted pressure differential for the top of the G1 sub-zone and Holt sub-zone is 246 psi in January 2037 and 849 psi in January 2029, respectively. The values are located at the top of injectors BRP CCS1 (G1 sub-zone) and CCS2 (Holt sub-zone). The magnitude and area of elevated pressure gradually decreases until the end of the injection period for the top of the Holt-sub-zone, and there is a sharp decrease in pressure when injection cease for both G4 and G1 injection sub-zones.

Table 1 and Table 2 shows the predicted pressure differential (pressure at Year – initial pressure) vs. time at the top of the G1 sub-zone and Holt sub-zone for the monitoring well locations in the AoR (Figure 9). The G1 sub-zone is reported because it is the top of the Injection Zone including the G1, G4 and Holt sub-zones. The top of the Holt sub-zone is reported because it is the region with the highest pressure differential in the simulation model. Note that the negative values at time zero result from a decrease in pressure due to brine production that starts six months prior to the commencement of CO₂ injection. The purpose of brine withdrawal is to manage reservoir pressure within the AoR.

The highest pressures are expected in the immediate vicinity of each injection well. The pressure is anticipated to quickly decrease below the estimated critical pressure in all areas of the site within a few years after the conclusion of injection operations (i.e., below the pressure levels at which fluids could be forced from the Injection Zone through a conduit into an overlying USDW). The pressure then stabilizes through the end of the post-injection site care period (PISC) and reaches similar values as those observed during pre-injection conditions.

Additional information on the projected post-injection pressure declines and differentials is presented in the Area of Review and Corrective Action Plan document.

Table 1—Pressure Differential to Pre-Injection Conditions at the top of the G1 sub-zone at monitoring well locations.

Well Name	SLR 1	SLR 2	SLR 3	WW1	WW2	WW3	WW4
Well distance from BRP CCS1 (ft)	8494	8093	5565	10,837	5772	9174	7598
Top of G1 sub-zone (ft MD)	4521	4538	4622	4470	4598	4463	4561
Year / Pressure Differential	psi	psi	psi	psi	psi	psi	psi
Start water production	0	0	0	0	0	0	0
0 (start injection)	-18	-15	-9	-42	-826	-314	-574
1	-34	-21	-26	-62	-856	-327	-646
2	-42	-14	-23	-91	-924	-483	-888
3	-36	-14	-22	-95	-924	-505	-965
4	-29	-7	-20	-92	-916	-497	-976
5	-23	0	-17	-89	-910	-490	-979
10	9	26	0	-67	-895	-463	-979
12 (end of injection)	23	34	6	-56	-892	-454	-978
15	24	39	24	19	47	32	-7
20	22	26	19	21	26	25	13
25	20	21	16	20	19	21	15
35	19	18	14	18	16	18	15
45	18	17	14	18	15	17	14
55	17	16	14	17	15	17	14
62 (site closure)	17	16	14	17	15	16	14

Table 2—Pressure Differential to Pre-Injection Conditions at the top of the Holt sub-zone at monitoring well locations.

Well Name	SLR 1	SLR 2	SLR 3	WW1	WW2	WW3	WW4
Well distance from BRP CCS2 (ft)	8,312	4,510	8,720	10,594	9,378	6,788	7,789
Top of Holt sub-zone (ft MD)	4883	4904	4972	4824	4968	4813	5021
Year / Pressure Differential	psi	psi	psi	psi	psi	psi	psi
Start water production	0	0	0	0	0	0	0
0 (start injection)	-18	-11	-4	-48	-41	-273	-201
1	-30	47	51	-68	-11	-282	-171
2	-36	74	86	-100	6	-419	-241
3	-24	157	177	-104	82	-430	-193
4	-16	200	236	-101	121	-421	-168
5	-9	225	268	-98	142	-413	-154
10	18	294	308	-76	193	-383	-137
12 (end of injection)	28	302	304	-65	201	-372	-139
15	23	94	120	19	81	42	76
20	21	38	43	21	32	28	32
25	19	24	23	20	21	22	20
35	17	18	15	18	15	18	15
45	17	17	13	17	14	17	14
55	16	16	13	17	14	17	13
62 (site closure)	16	16	13	17	14	16	13

Figure 1 and 2 show the simulated pressure vs. time for the BRP CCS1, CCS2 and CCS3 and monitoring well locations at the top of the commingled G4/G1 sub-zones and the top of the Holt sub-zone, respectively.

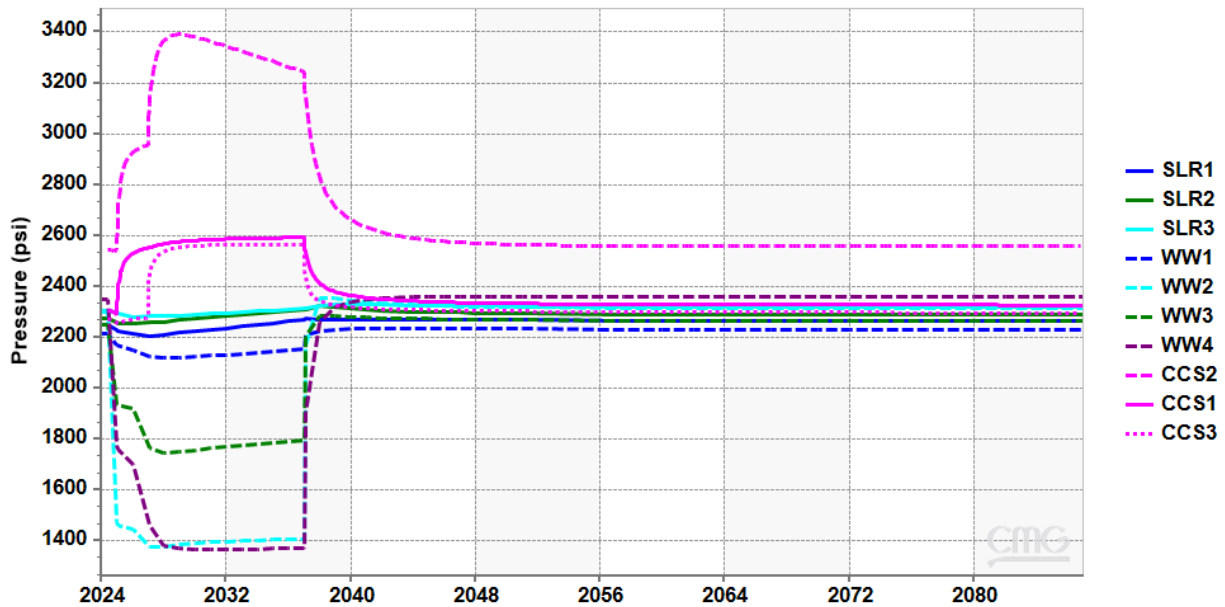

Figure 1--Simulated pressure vs. time at the top perforation in the BRP CCS1, CCS2 and CCS3 injection wells and at the top of the commingled G4/G1 sub-zones at monitoring well locations.

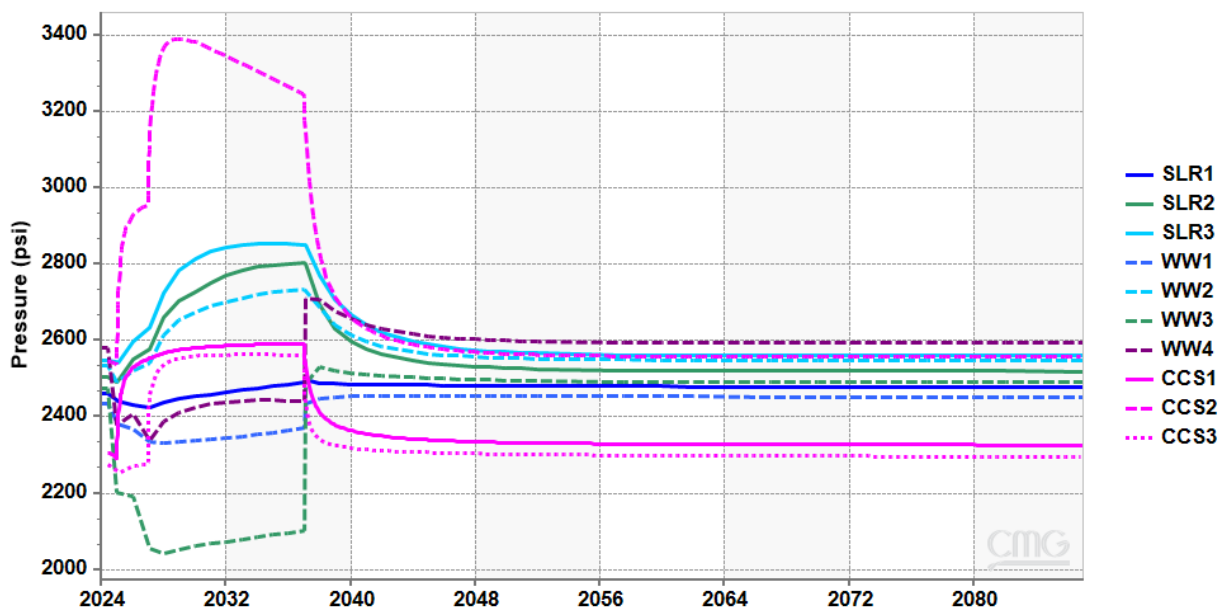

Figure 2--Simulated pressure vs. time at the top perforation in the BRP CCS1, CCS2 and CCS3 injection wells and at the top of the Holt sub-zone at monitoring well locations.

Plan Revision number: 3
Plan revision date: 07/30/2024

Figure 3 and Figure 4 show the simulated pressure differentials from the critical pressure values at the top of the Holt sub-zone at the end of injection and 50 years after the end of injection, respectively. In Figure 2, only the values that exceed the critical pressure threshold are shown, indicating that any area outside the shown values is below the critical pressure. In Figure 3, the pressure differential shows a negative pressure differential for most of the area, indicating that the pressure has dissipated below the critical pressure in all areas of the site at Year 62, which is anticipated to be the year of site closure.

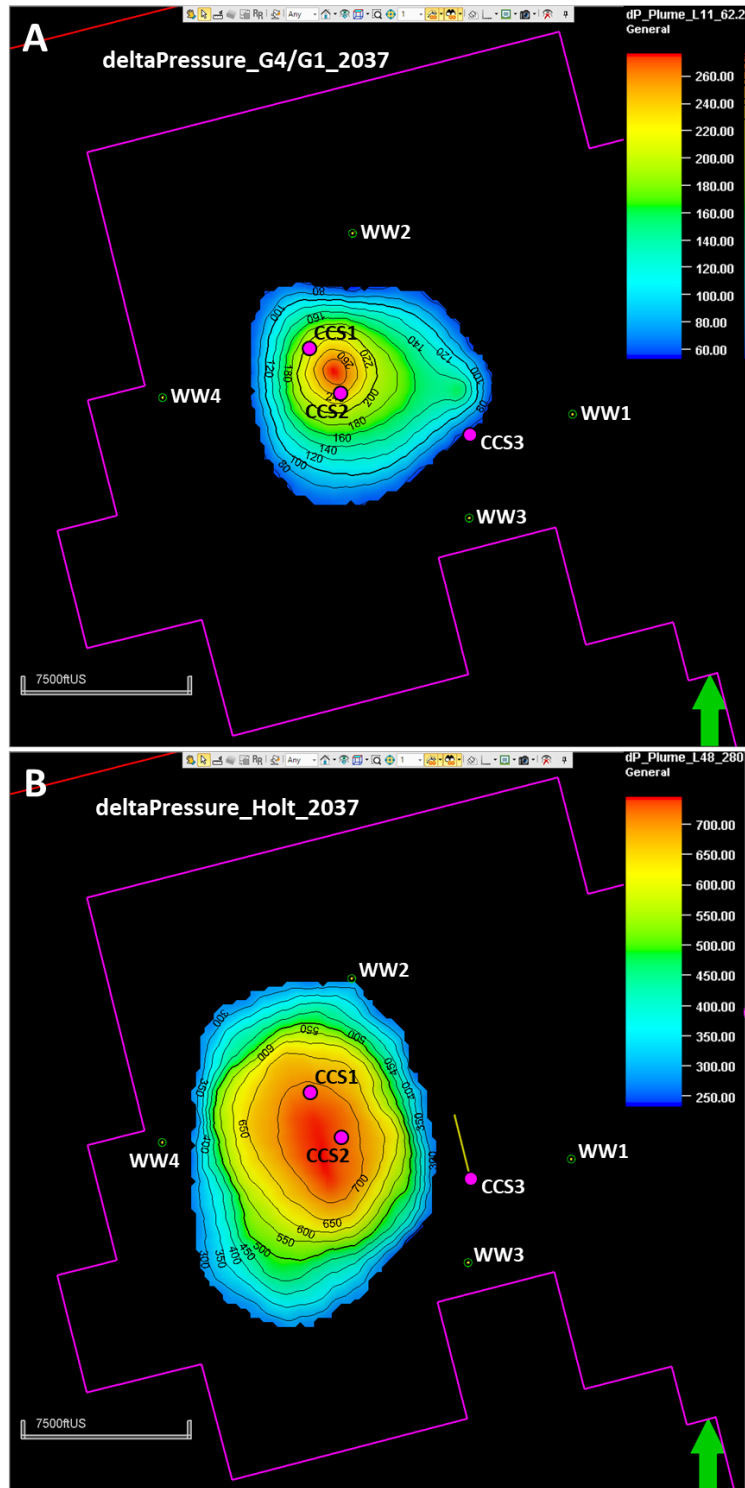

Figure 3--Aqueous pressure differential from the initial condition for commingled sub-zones G4 and G1 (upper Injection Zone – subplot A) and for sub-zone Holt (lower Injection Zone – subplot B) at end of injection in January 2037.

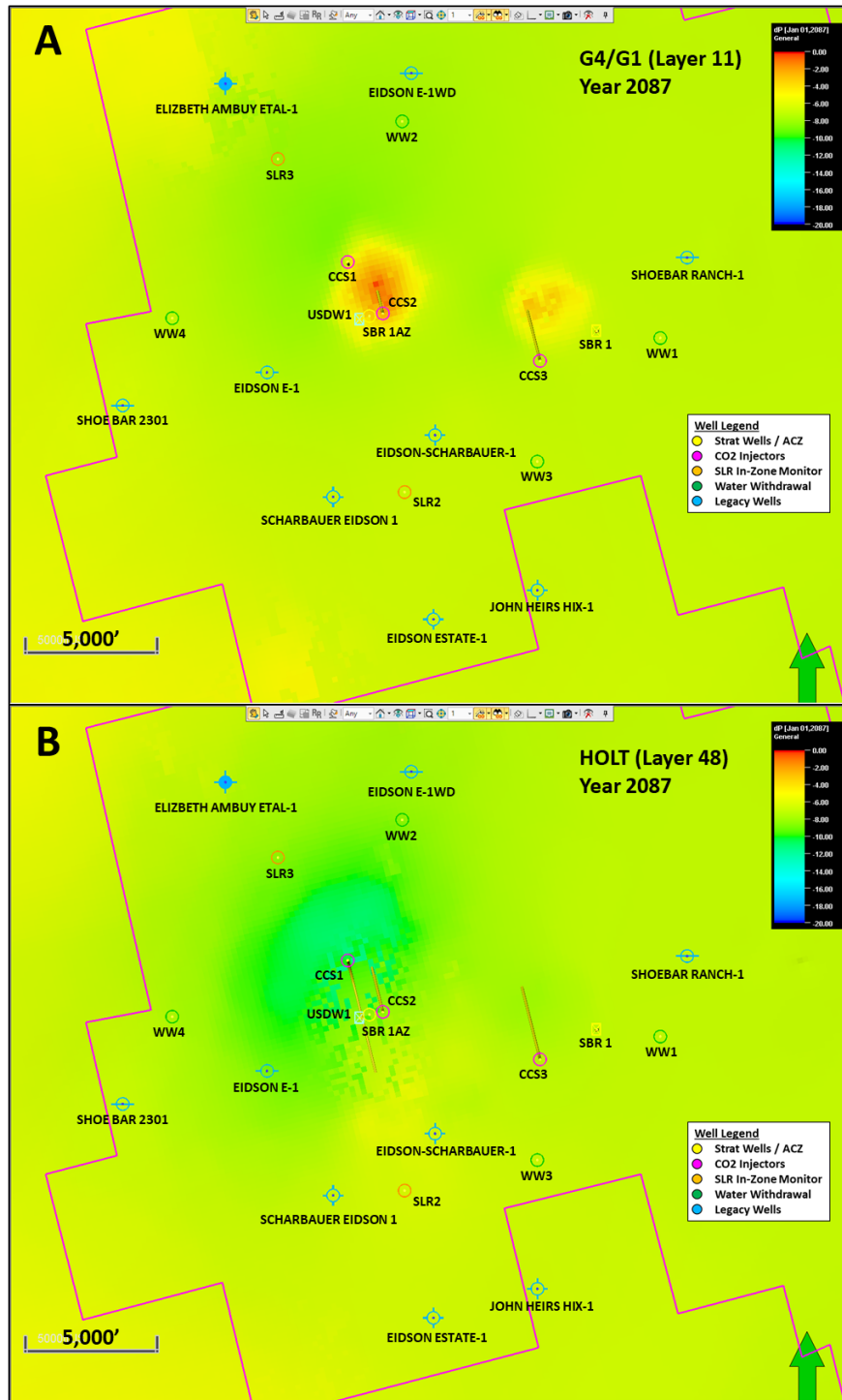

Figure 4--Aqueous pressure differentials from the initial condition at the top of the commingled G4 and G1 sub-zones (subplot A) and the top of the Holt sub-zone (subplot B) in January 2087 (50 years post-injection).

4.0 Predicted Position of the CO₂ Plume and Associated Pressure Front at Site Closure **[40 CFR §146.93(a)(2)(ii)]**

The reservoir simulation indicates that after injection ceases, the predicted CO₂ plume remains within the Lower San Andres Formation and the area does not expand over time. The colored area in Figure 5 shows the CO₂ plume extent in Year 62, as defined by the global mole fraction of CO₂. Figure 6 to 8 show a N-S cross section with the CO₂ global mole fraction at the end of the injection period at Year 12 and the Year 62 for wells BRP CCS1, CCS2, and CCS3, respectively. There is some minor vertical migration of CO₂ to upper portions of the Injection Zone due to buoyancy forces. The AoR is defined by the plume shape and size in Year 12 (end of injection period) because this is the time with the largest differential pressure and CO₂ plume. Also, as previously shown in Figure 3, all pressures are predicted to have been reduced to levels below the level of endangerment to USDWs by Year 62. Therefore, Year 62 (50 years post-injection) is predicted to be the site closure date.

The map in Figure 5 is based on the final AoR delineation modeling results submitted pursuant to 40 CFR §146.84.

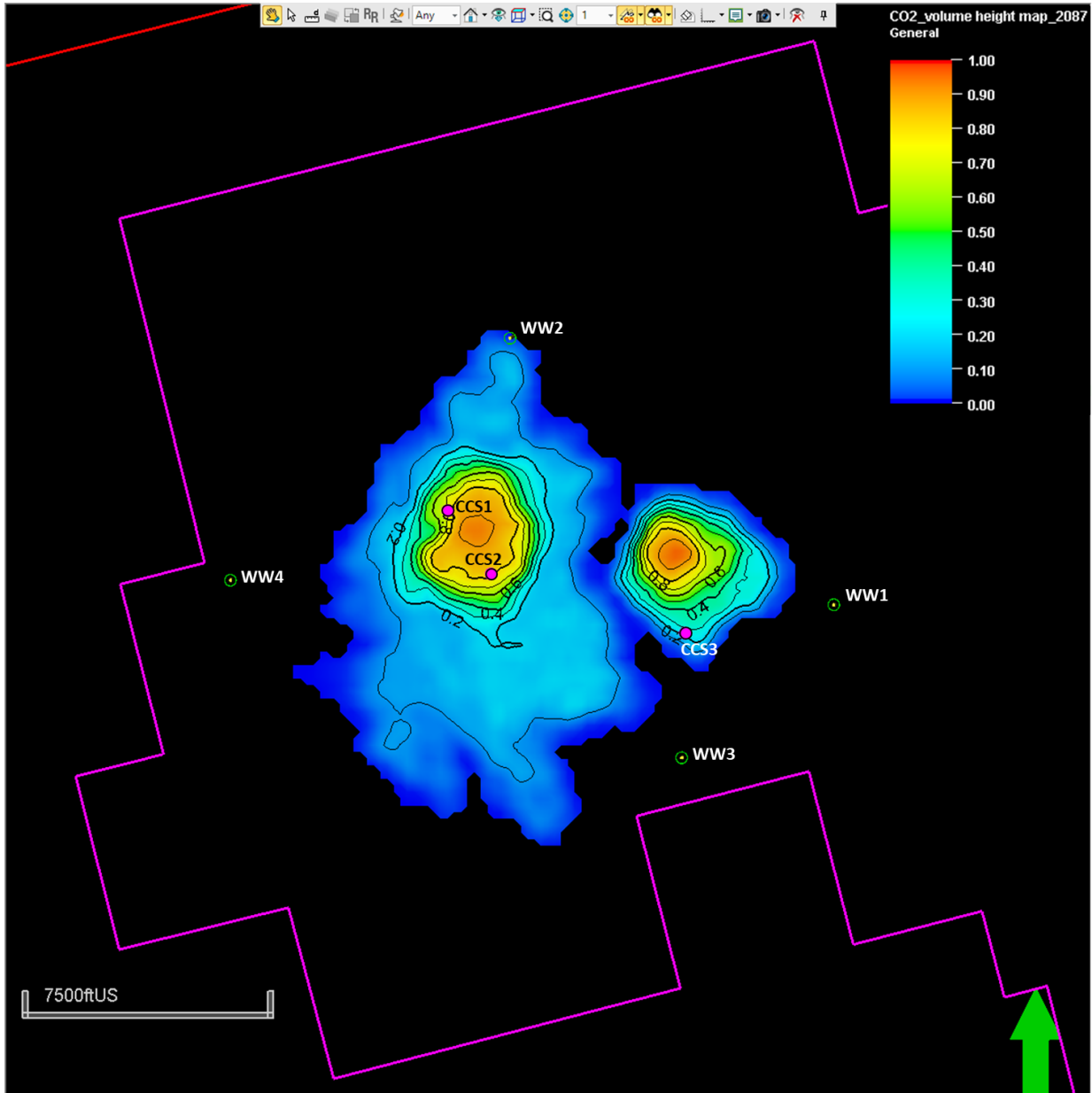

Figure 5--Areal extent of the CO₂ plume at site closure in Year 62 since start of CO₂ injection (2087), defined by the vertical integration of saturation of CO₂ injected.

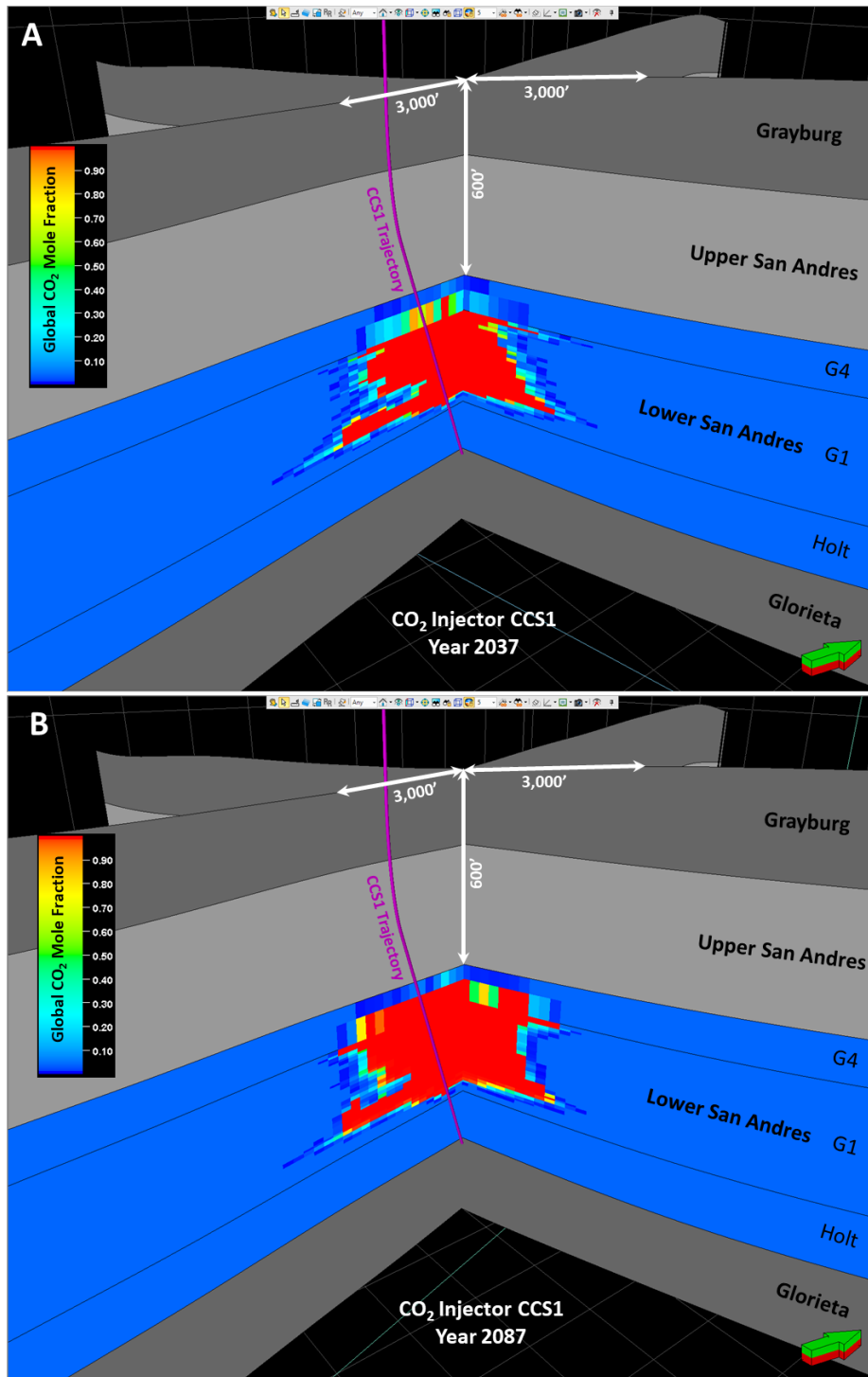

Figure 6--Cross section through the geomodel with simulated CO₂ plume for injector CCS1 at the end of injection period in 2037 (subplot A) and at time of site closure in 2087 (subplot B).

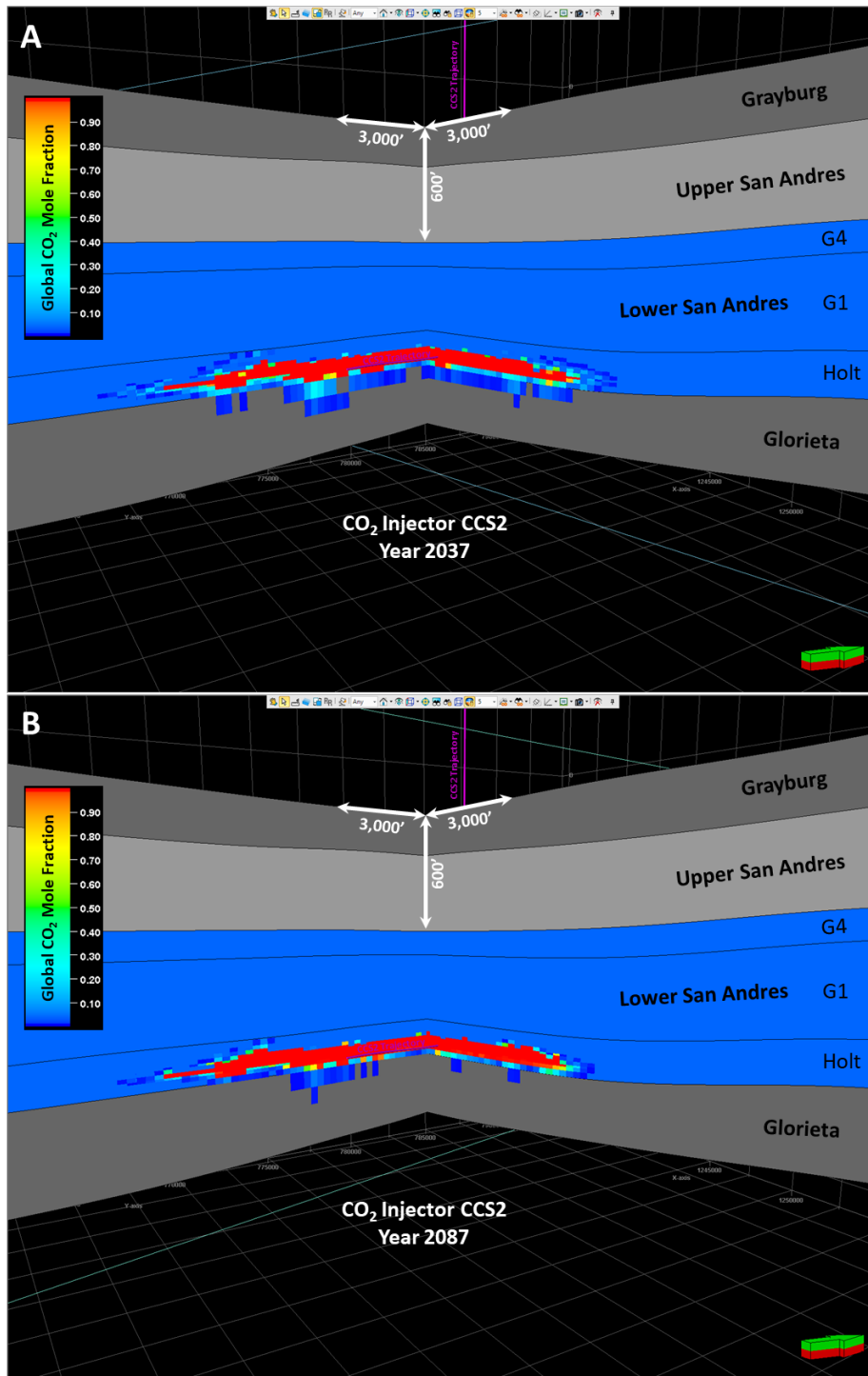

Figure 7--Cross section through the geomodel with simulated CO₂ plume for injector CCS2 at the end of injection period in 2037 (subplot A) and at time of site closure in 2087 (subplot B). Note that the large grid blocks in the Glorieta formation are an upscaling artifact. CO₂ is only pushed into the uppermost part of the Glorieta formation and moves upward over time due to buoyancy.

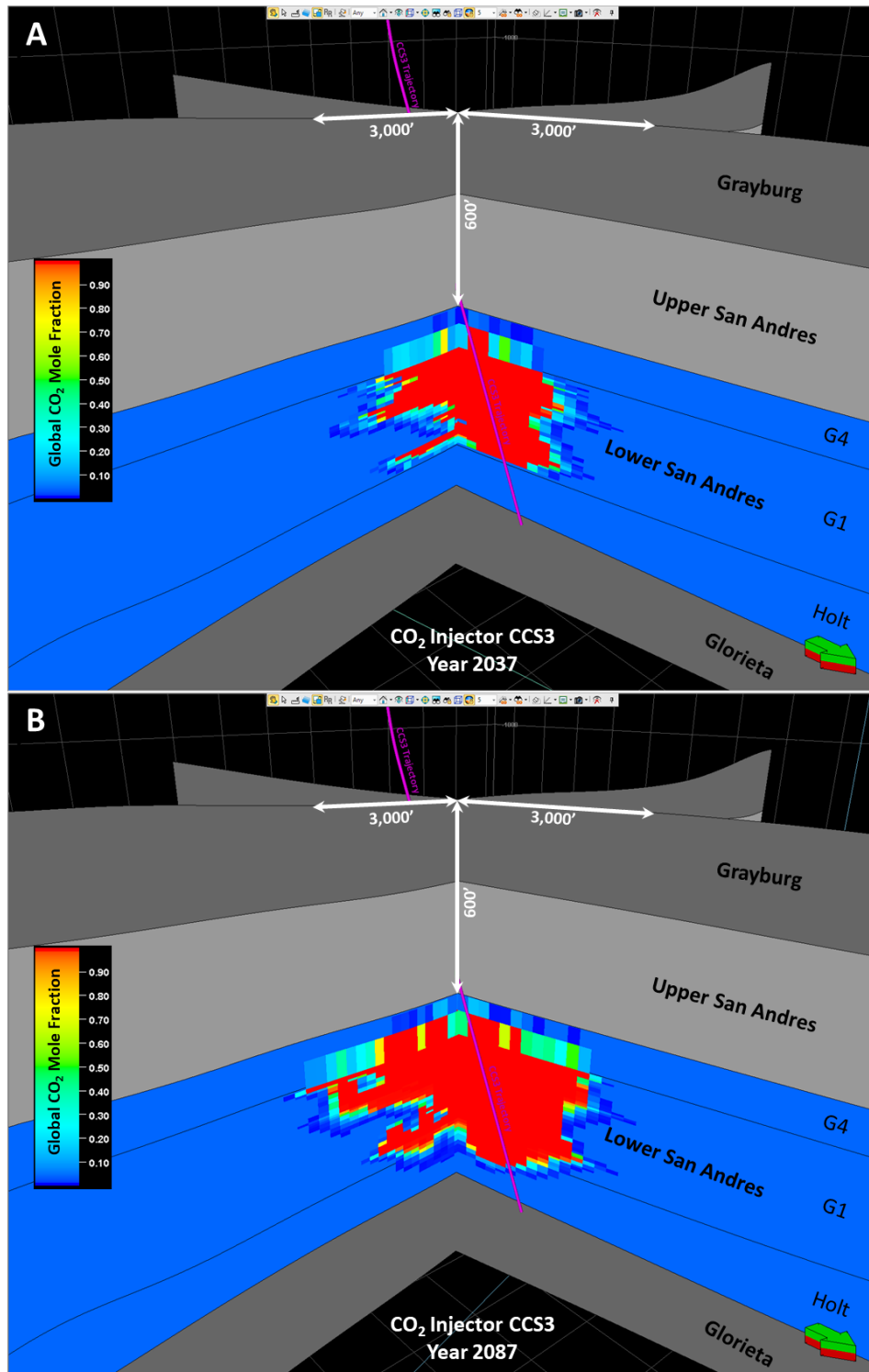

Figure 8--Cross section through the geomodel with simulated CO₂ plume for injector CCS3 at the end of injection period in 2037 (subplot A) and at time of site closure in 2087 (subplot B).

Figure 9 shows the CO₂ plume size, injected mass, and storage capacity as a function of time, with Year 0 being the initiation of injection. The simulation model predicts that the CO₂ plume (defined as the area containing 99% of the total volume of injected CO₂) increases rapidly during injection. The maximum CO₂ plume area is 4.8 mi² at the end of the injection period with a storage capacity of 1.77 MMT/mi². The plume shrinks after the injection stops from Year 12 to Year 50 and stabilizes in the following years. The shrink behavior of the plume after is due to the buoyancy of the mobile supercritical CO₂ phase which moves in upward direction, and continued dissolution in aqueous phase, decreasing its concentration in the plume edges. Thus, the storage capacity increase until a maximum of 1.95 MMT/mi². Figure 10 depicts areal plume movement based on CO₂ global mole fraction with a 0.1% cutoff. The plume slightly moves from west to east direction, close to Shoe Bar 1 well, due to the model geological features combined with compressibility effect (lower pressure in that region from WW1 water withdraw) allowing small plume migration in the strata. The change in plume size is negligible 50 years after injection, which is the proposed site closure time.

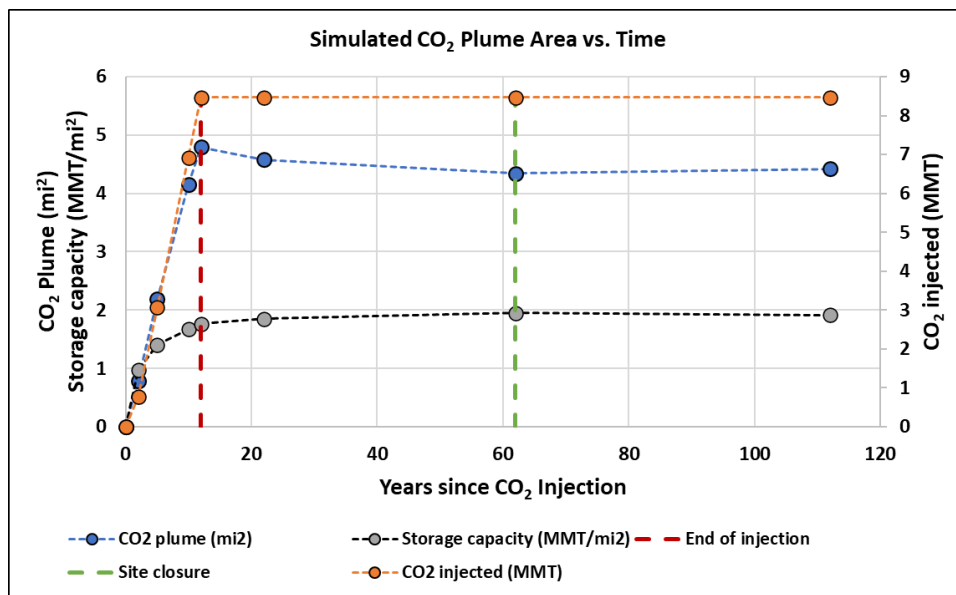

Figure 9--Simulated CO₂ plume area, injected mass, and storage capacity over time. The red and green dashed line denotes the time of end of injection and site closure, respectively.

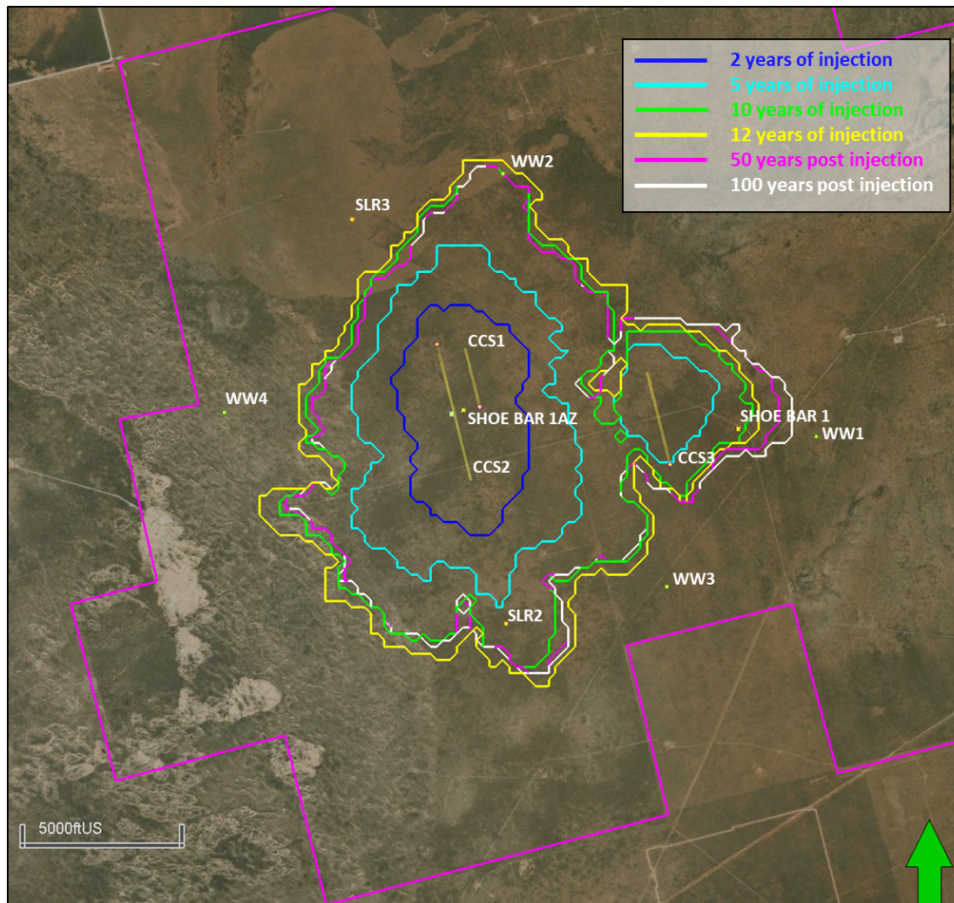

Figure 10--Simulated areal extent of the CO₂ plume from injection start-up to shut-in, then to 100 years after shut-in. Colored outlines represent the migration of the 1% CO₂ saturation front through time.

5.0 Post-Injection Monitoring Plan [40 CFR §146.93(b)(1)]

As described in the following sections, groundwater quality monitoring and plume and pressure-front tracking during the post-injection phase will meet the requirements of 40 CFR §146.93(b)(1). The results of all post-injection phase testing and monitoring will be submitted annually, within 60 days of the anniversary of the date that injection ceases, as described below under Section 5.3 Schedule for Submitting Post-Injection Monitoring Results [40 CFR §146.93(a)(2)(iv)]. Please refer to the Testing and Monitor Plan and Quality Assurance and Surveillance Plan (QASP) document included as part of this application for additional details on testing and monitoring activities during the Post-Injection phase.

A summary of key components of the PISC plan is as follows:

- After the injection ceases, the Injector wells will be plugged and abandoned according to the procedure proposed in the Plugging Plan document of this permit application.
- Pending an approved PISC Plan, for the first 10 years after the cessation of injection, direct measurements of pressure and temperature in the Injection Zone will be obtained in Single Layer Reservoir (SLR) monitoring wells that have not yet been plugged. Fluid samples will be collected if pressure or temperature indicate a change in fluid encountered by the wellbore. If pressure and temperature data are consistent with lack of continued CO₂ migration, pressure and temperature monitoring in the Injection Zone will be continued annually after 10 years until plugging.
- Pending an approved PISC Plan, for the first 10 years following the cessation of injection operations, OLCV will annually collect and analyze the geochemistry of fluids and dissolved gasses from the lowermost USDW in the USDW1 well. These data will confirm the integrity of the Upper Confining Zone. Measurements will be event-driven thereafter. If geochemistry data of fluids and dissolved gasses in the lowermost USDW are consistent with the absence of introduced Injection Zone brine or CO₂ injectate into the USDW, this monitoring method will be discontinued after 10 years.
- If pressure or temperature data in the SLR wells indicates a change in the Injection Zone that could indicate migration of CO₂ plume out of the storage complex, soil gas analysis will be conducted. If changes in soil gas are detected, an attribution study will be performed.
- Annual saturation logging will be conducted in SLR2 and SLR3 wells until plugging and saturation logging will be conducted once every five-year period in ACZ1 and SLR1 if triggered by other data.
- Time-lapse VSP data will be collected in selected SLR wells that have DAS fiber once every five-year period until plugging.
- 2D time-lapse surface seismic will be collected once every five-year period until plume stabilization.
- DInSar and GPS data will be analyzed annually for the first five years post injection.

5.1 Monitoring Above the Upper Confining Zone

Table 3 presents the monitoring methods, locations, and frequencies for monitoring above the Upper Confining Zone.

Table 3—Post-Injection Monitoring Techniques in/above the Confining Zone

Location	Objective	Method	Monitoring Post-Injection
Lowermost USDW / first permeable zone above the confining zone monitoring	Geochemical and isotopic monitoring to detect deviations from expected fluid chemistry	Fluid and dissolved gas sampling	Event-driven*, until plugging
Vadose Zone, Near surface	Isotopic analysis and chemical evaluation to detect changes from expected vadose zone chemistry	Isotopic analysis and chemical evaluation at a minimum of 15 locations	Event-driven*, triggered by P/T data in SLR or ACZ1 wells and fluids sample results
ACZ1 and/or SLR1	Confirming integrity of the Upper Confining Zone	Saturation logging (RST/PNL)	Event-driven*, until plugging
		DTS (SLR1 only)	Continuously for the first 10 years, pending an approved PISC plan

*OLCV will monitor pressure and temperature data obtained from downhole gauges and/or DTS fiber daily, and also routinely evaluate long-term data trends to detect deviations from the reference temperature or pressure gradient. If persistent deviations in temperature or pressure are detected, OLCV will obtain reservoir fluid samples and analyze fluid and dissolved gas chemistry to determine the presence or absence of increased CO₂. In addition, fluid and dissolved gas chemistry data from the lowermost USDW and soil gas chemistry from shallow soils will be monitored for trends to detect deviations from reference chemistry. If persistent and/or abrupt anomalies in chemistry are detected additional fluid or soil gas samples will be obtained to confirm the presence or absence of increased CO₂. Saturation logging may also be conducted to further support or refute the presence of increased CO₂.

5.2 Carbon Dioxide Plume and Pressure Front Tracking [40 CFR §146.93(a)(2)(iii)]

OLCV will employ direct and indirect methods to track the extent of the CO₂ plume and the presence or absence of elevated pressure. Table 4 presents the direct and indirect methods that OLCV will use to monitor the CO₂ plume, including the activities, locations, and frequencies. Fluid sampling, sampling handling and custody, quality control, and quality assurance will be performed as described in the QASP.

Table 4—Post-Injection Monitoring Techniques Plume and Pressure Front Tracking

Location	Objective	Method	Monitoring Post-Injection
SLR2 and SLR3, Injection Zone monitor wells	Fluid and dissolved gas chemistry	Fluid and dissolved gas sampling via wireline	Event-driven* until plugging
	Direct monitoring of pressure and temperature to ensure seal integrity	P/T gauges or DTS	Continuously for the first 10 years pending an approved PISC plan, then annually until plugging

	Indirect monitoring of CO ₂ concentration	PNL or RST	Annually until plugging
	Plume and pressure extent over time	2D VSP	Once every five-year period until plugging or plume stabilization
	Internal and external mechanical integrity	Pressure and temperature gauges; external MIT	MIT log once every five-year period and before plugging
	Surface leak detection	Visual inspection at wellhead, LDAR/OGI cameras, surface sensors	Continuous surface monitoring and quarterly visual inspection until site closure
ACZ1 and SLR1, Confining Zone monitoring wells	Direct monitoring of pressure and temperature to ensure Upper Confining Zone integrity	DTS (SLR1 only)	Continuously for the first 10 years or until plugging, pending an approved PISC Plan
	Internal and external mechanical integrity	Pressure and temperature gauges; external MIT	MIT log once every five-year period and before plugging
	Indirect monitoring of CO ₂ presence above the Injection Zone	PNL or RST	Event-driven* until plugging
	Surface leak detection	Visual inspection at wellhead, LDAR/OGI cameras, surface sensors	Continuous surface monitoring and quarterly visual inspection until site closure
Lowermost USDW monitor well	Geochemical and isotopic monitoring to detect deviations from expected fluid chemistry	Fluid and dissolved gas sampling	Annually for first 10 years post injection pending an approved PISC plan; event-driven*, triggered by P/T data in SLR wells or soil gas chemistry
Vadose Zone, Near surface	Isotopic analysis and chemical evaluation to detect changes from expected vadose zone chemistry	Isotopic analysis and chemical evaluation at a minimum of 15 locations	Event-driven*, triggered by P/T data in SLR wells or fluid sample results
2D VSP in selected SLR wells and 2D surface seismic	Estimate CO ₂ plume and pressure extent	2D VSP and 2D surface seismic	Once approximately every five-year period until plugging or plume stabilization
DInSAR with GPS	Estimate CO ₂ plume and pressure extent	DInSAR with GPS	Annually for five years or until plume stabilizes
Surface seismicity	Presence or absence of seismicity	Seismometers	Continuous monitoring and recording until site closure

*OLCV will monitor pressure and temperature data obtained from downhole gauges and/or DTS fiber daily, and also routinely evaluate long-term data trends to detect deviations from the reference temperature or pressure gradient. If persistent deviations in temperature or pressure are detected, OLCV will obtain reservoir fluid samples and analyze fluid and dissolved gas chemistry to determine the presence or absence of increased CO₂. In addition, fluid and dissolved gas chemistry data from the lowermost USDW and soil gas chemistry from shallow soils will be monitored for trends to detect deviations from reference chemistry. If persistent and/or abrupt anomalies in chemistry are detected additional fluid or soil gas samples will be obtained to confirm the presence or absence of increased CO₂. Saturation logging may also be conducted to further support or refute the presence of increased CO₂.

5.3 Schedule for Submitting Post-Injection Monitoring Results [40 CFR §146.93(a)(2)(iv)]

OLCV will re-evaluate the AoR every five years during the post-injection phases. In addition, monitoring and operational data will be reviewed periodically by OLCV during the injection and post-injection phases. Monitoring reports will be prepared and submitted to the EPA Region 6 UIC Branch office twice per year. These reports will summarize methods and results of groundwater quality monitoring, CO₂ Injection Zone pressure tracking, and indirect geophysical monitoring for CO₂ plume tracking.

The PISC and Site Closure Plan will be reviewed every five years during the PISC period. Results of the plan review will be included in the PISC monitoring reports. The operational and monitoring results will be reviewed for adequacy in relation to the objectives of the PISC. The monitoring locations, methods, and schedule will be analyzed in relation to the size of the CO₂ Injection Zone, pressure front, and protection of USDWs. In case of changes to the PISC plan, a modified plan will be submitted to the EPA Region 6 UIC Branch Office within 30 days of such changes.

6.0 Non-Endangerment Demonstration Criteria

Prior to approval of the end of the post-injection phase, OLCV will submit a demonstration of non-endangerment of USDWs to the UIC Program Director, per 40 CFR §146.93(b)(2) and (3). This demonstration of USDW non-endangerment will be based on the evaluation of the site monitoring data used in conjunction with the project's computational model. The demonstration will include all relevant monitoring data and interpretations upon which the non-endangerment demonstration is based, model documentation and all supporting data, and any other information necessary for the UIC Program Director to review the analysis. The demonstration will include the following sections:

6.1 Introduction and Overview

A summary of relevant background information will be provided, including the operational history of the injection project, the date of the non-endangerment demonstration relative to the post-injection period outlined in this PISC and Site Closure Plan, and a general overview of how monitoring and modeling results will be used together to support a demonstration of USDW non-endangerment.

6.2 Summary of Existing Monitoring Data

A summary of all previous monitoring data collected at the site, pursuant to the Testing and Monitoring Plan document and this PISC and Site Closure Plan, including data collected during the injection and post-injection phases of the project, will be submitted to help demonstrate non-endangerment. Data submittals will be in a format acceptable to the UIC Program Director, and will include a narrative explanation of monitoring activities, including the dates of all monitoring events, changes to the monitoring program over time, and an explanation of all monitoring infrastructure that has existed at the site. Data will be compared with baseline data collected during site characterization.

6.3 Summary of Computational Modeling History

The computational modeling results used for the AoR delineation will be compared to monitoring data collected during the operational and PISC periods. Monitoring data will also be compared with baseline data collected during the site characterization required under 40 CFR §146.82(a)(6) and §146.87(d)(3). The data will be used to update the computational model and monitor the site and will include both direct and indirect geophysical methods. Direct methods include measurements of pressure, temperature, fluid and dissolved gas chemistry. Indirect methods include Vertical Seismic Profile (VSP) and 2D seismic, Differential Interferometric Synthetic-Aperture Radar (DInSAR), and saturation logging using Pulsed Neutron (PNL).

Data generated during the PISC period will be used to show that the computational model accurately represents the storage site and can be used as a proxy to determine the plume's properties and size. OLCV will demonstrate this degree of accuracy by comparing the monitoring data obtained during the PISC period with the model's predicted properties (i.e., plume location, rate of movement, and pressure decay). Statistical methods will be employed to correlate the data and confirm the model's ability to represent the storage site accurately. The validation of the computational model with the large quantity of measured data will be a significant element to support the non-endangerment demonstration. Further, the validation of the complete model over the entire area, and at the points where direct data collection has taken place, will ensure confidence in the model for those areas with no direct observation wells where the surface infrastructure precludes geophysical data collection.

6.4 Evaluation of Reservoir Pressure

OLCV will demonstrate non-endangerment to USDWs by showing that the pressure within the Injection Zone will rapidly decrease to levels near its pre-injection static reservoir pressure during the PISC period. Because increased pressure is the primary driving force for fluid movement that

could endanger a USDW, the decay in the pressure differential provides strong justification that the injectate will no longer pose a risk to any USDWs.

OLCV will monitor the downhole reservoir pressure at various locations and intervals using a combination of surface and downhole pressure gauges. The measured pressure at a specific depth interval will be compared with the pressure predicted by the computational model, which was previously shown in Figure 1, Figure 2, and Figure 3. Agreement between the actual and predicted values will validate the accuracy of the model and further demonstrate non-endangerment.

6.5 Evaluation of Carbon Dioxide Plume

OLCV will use a combination of monitoring data, logs, geophysical surveys, and seismic methods to locate and track the movement of the CO₂ plume. The data produced by these activities will be compared with the modeled predictions (previously shown in Figure 7) using statistical methods to validate the model's ability to represent the storage site accurately. PISC monitoring data will be used to show the stabilization of the CO₂ plume as the reservoir pressure returns to its near-pre-injection state. The risk to USDWs will decrease when the extent of pure-phase CO₂ ceases to grow either laterally or vertically. The stabilization of the CO₂ plume combined with the lack of unmitigated Artificial Penetrations in the confining formation will be significant factors in the Project's demonstration of non-endangerment.

Fluids and dissolved gasses collected from USDW1 or soil or soil gas samples may be used to determine aqueous-phase CO₂ concentrations and mobilized constituents to assess USDW endangerment. If a demonstration can be made that the majority of the CO₂ has been immobilized via trapping mechanisms, then there is strong evidence that the risk to USDWs posed by the CO₂ plume has decreased. Modeling results, including sensitivity analyses, may also be used to demonstrate that plume migration rates are negligible based on available site characterization, monitoring, and operational data.

6.6 Evaluation of Emergencies or Other Events

In addition to the CO₂ plume, mobilized fluids may also pose a risk to USDWs, as the reservoir fluids include brines that are high in total dissolved solids (TDS) and contain hydrogen sulfide. The geochemical data collected from monitoring wells will be used to demonstrate that no mobilized fluids have moved above the Upper Confining Zone and therefore would not pose a risk to USDWs after the PISC period. Monitoring data indicating steady or decreasing trends of potential drinking water contaminants below actionable levels (e.g., secondary, and maximum contaminant levels) will be used for this demonstration.

To demonstrate non-endangerment, OLCV will compare the operational and PISC period fluid and dissolved gas samples from the lowermost USDW with the pre-injection baseline samples. This comparison is expected to show chemical similarity to baseline samples. Changes in chemistry will be evaluated to demonstrate attribution. This work will demonstrate the absence of CO₂ injectate or brine forced from the Injection Zone into the lowermost USDW.

Corrective action will be performed on Artificial Penetrations identified to be potential leak pathways. Based on this information, the potential for fluid movement through artificial penetrations of the confining formation does not present a risk of endangerment to any USDWs.

7.0 Site Closure Plan

OLCV will conduct site closure activities to meet the requirements of 40 CFR §146.93(e) as described below. OLCV will submit a final Site Closure Plan and notify the permitting agency at least 120 days in advance of its intent to close the site. Once the permitting agency has approved closure of the site, OLCV will plug the monitoring wells and submit a site closure report to EPA within 90 days of site closure. The activities described below represent the planned activities based on information provided to EPA. The actual site closure plan may employ different methods and procedures. A final Site Closure Plan will be submitted to the UIC Program Director for approval with the notification of the intent to close the site.

7.1 Plugging Monitoring Wells

Upon receiving authorization for site closure from the Director, all monitoring wells will be plugged within 90 days of site closure. All Injection Zone monitoring wells at the site will be plugged and abandoned using best practices to prevent any upward migration of the CO₂ or communication of fluids between the Injection Zone and USDWs. The deep monitoring wells in the Injection Zone have a direct connection between the injection formation and the ground surface; therefore, the well plugging program is specifically designed to prevent communication between the Injection Zone and USDWs. Details of the Plugging Program are located in the Plugging Plan document.

Before the wells are plugged, the internal and external integrity of the wells will be confirmed by conducting a pressure test and a cement and casing inspection log. The results of this logging and testing will be reviewed and approved by the appropriate regulatory agencies before plugging the wells.

Infrastructure removal and site restoration efforts will comply with applicable state and local requirements

7.2 Site Closure Report

A Site Closure Report (SCR) will be prepared and submitted to the Director within 90 days after site closure. The SCR will document the following aspects of the site closure process:

- Plugging of all injection, water withdraw and monitoring wells;
- Details of site restoration activities;
- Location of the sealed injection well on a survey plat submitted to the local zoning authority, a copy of which will be sent to the Regional Administrator for EPA Region 6;
- Notifications sent to state and local authorities;
- Records regarding the nature, composition, and volume of CO₂ injected;
- Records of pre-injection, injection, and post-injection monitoring; and
- Certifications that all injection and storage activities have been completed.

OLCV will record a notation on the deed of the property on which the injection well was located, which will include the following:

- An indication that the property was used for carbon dioxide sequestration,
- The name of the local agency to which the survey plat with injection well location was submitted,
- The volume of fluid injected,
- The Injection Zone or zones into which the fluid was injected, and
- The period over which the injection occurred.

The site closure report will be submitted to the permitting agency and maintained by the owner or operator for a period of 10 years following site closure. Additionally, the owner or operator will maintain the records collected during the post-injection site care period for a period of 10 years after which these records will be delivered to the UIC Program Director.

J. FINANCIAL ASSURANCE DEMONSTRATION

**RRC FINANCIAL ASSURANCE DEMONSTRATION PLAN
In Satisfaction of 16 TAC 5.205 and 40 CFR 146.82(a)(14) and (19), 146.85**

Brown Pelican CO₂ Sequestration Project

1.0 Facility Information and Overview..... 1
2.0 Activities Requiring Financial Assurance 2
3.0 Instruments to Meet Financial Responsibility 2
4.0 Cost Estimate for Activities Covered by Financial Responsibility 3

1.0 Facility Information and Overview

Facility name: Brown Pelican CO₂ Sequestration Project
BRP CCS 1, CCS2 and CCS 3 Wells

Facility contact: 

Well location: Penwell, Texas

BRP CCS1	31.76481926	-102.72891895
BRP CCS2	31.76994887	-102.73320589
BRP CCS3	31.76024766	-102.71013484

The matter of financial assurance demonstration is relevant to the requirements of 16 TAC 5.205 and the Environmental Protection Agency (EPA) document 40 CFR Subpart H - Criteria and Standards applicable to Class VI Wells. The main topics covered in this document are activities requiring financial assurance, instruments to meet financial responsibility, and the plan to be implemented by Oxy Low Carbon Ventures, LLC (“OLCV”) for the Brown Pelican CO₂ Sequestration Project (“BRP Project” or “Project”).

2.0 Activities Requiring Financial Assurance

Pursuant to 16 TAC 5.205 and 40 CFR 146.85, OLCV, is required to demonstrate financial ability to successfully complete all the tasks associated with performing corrective action, plugging injection and monitoring wells, post-injection site care, site closure, and implementation of an emergency remedial response plan as specified in Table 1.

Table 1—List of Project activities that require Financial Assurance

Activity	Period of Performance
Performing corrective action	As needed
Plugging injection and monitoring wells	One time
Post-injection site care	Throughout the post-injection phase
Site closure	One time
Emergency/remedial response	As needed

3.0 Instruments to Meet Financial Responsibility

OLCV has reviewed the requirements of 16 TAC 5.205 and the extensive guidance, research, and analysis documents published by the EPA and proposes to utilize a letter of credit to demonstrate financial responsibility for all activities requiring financial assurance. The letter of credit will be issued by [REDACTED] that has (a) assets of at least Ten Billion Dollars (\$10,000,000,000) and (b) has a Long-Term Credit Rating of at least “A-” by S&P and at least “A3” by Moody’s. The letter of credit will be irrevocable, require the issuing institution to provide notice if it does not plan to reissue the letter of credit and will include a provision for automatic renewal. [REDACTED] maintains a "Certificate of Account Status," previously called "Certificates of Good Standing," with the Texas Comptroller of Public Accounts evidencing the status of its right to conduct financial transactions in Texas (which may be confirmed by entering [REDACTED] at this link maintained by the Texas Comptroller: [Taxable Entity Search \(state.tx.us\)](#)). Depending on the agency directing activities at the BRP Project, OLCV shall deposit funds as instructed by the Texas Railroad Commission or OLCV will establish a standby trust fund in accordance with EPA’s guidance to receive any funding necessary to address the cost of covered activities. OLCV may change the instrument(s) used to demonstrate financial assurance in accordance with 16 TAC 5.205 or 40 CFR 146.85.

4.0 Cost Estimate for Activities Covered by Financial Responsibility

In accordance with 40 CFR 146.85 *et seq.* and 16 TAC 5.205 (c)(2)(C)(i), the cost estimates must be performed for each phase separately and must be based on the costs to the regulatory agency of hiring a third party to perform the required activities.

OLCV will provide financial assurance sufficient to cover the costs identified in Table 2. Costs are in 2025 \$USD. A detailed cost estimate is included as a separate document PBI_FA_BRP_COST_EST_V5_2025.pdf.

Table 2—Cost Estimate for Activities Covered by Financial Assurance

Activity	Cost (Millions of \$USD); Undiscounted
Performing corrective action	0
Plugging injection wells	0.71
Post-injection site care	11.25
Site closure	2.02
Plugging USDW well	0.77
Emergency/remedial response	1.49
Regulatory fee	2.50
Total Cost	18.05

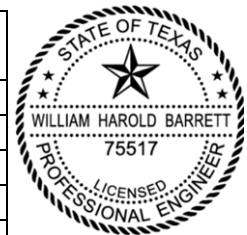

William H. Barrett
Sept. 27, 2025

4.1 Performing Corrective Action

Three wells within the Area of Review (AoR) were determined to require corrective action. OLCV conducted corrective action on: Eidson-E-1 (API 4213531130), Scharbauer Eidson-1 (API 4213510667) and Eidson Scharbauer-1 (API 4213506139) from November 2024 to February 2025. OLCV's actions will prevent migration of Injection Zone fluids or brine into the USDW through these legacy APs.

4.2 Plugging Injection Wells

Details of the well plugging plan are found in the Plugging Plan document of this permit application.

4.3 Post-Injection Site Care

Details of the post-injection site care plan are found in the Post Injection Site Care and Site Closure Plan document of this permit application. Post-injection site care costs were estimated from cessation of injection to site closure and account for seismic studies at five-year intervals, maintenance of the wells until closure, and monitoring the site to ensure protection of the USDW.

4.4 Site Closure

Details of the site closure plan are found in the Post Injection Site Care and Site Closure Plan document of this permit application.

Surface infrastructure removal and restoration scope is included in the Site Closure and includes such items as:

- CO₂ pipeline abandonment and right-of-way restoration
- Removal of pipeline valve stations
- Removal of surface facilities including pig traps, meters, monitors, etc.
- Restoration of CO₂ injector well pads
- Removal of electrical infrastructure such as de-commissioned powerlines and communications panels

4.5 Emergency and Remedial Response

Details of the emergency and remedial response plan are found in the Emergency and Remedial Response plan document of this permit application.

Explanation of Cost Estimates

The instrument values included in this document are based upon cost estimates by the BRP Project team with input cost data from third party service providers. Cost estimates were provided during the permit application process. If the cost estimates change during the permitting process or the life of the Project, OLCV will adjust the value of the financial instruments.

The BRP Project uses a Carbon Capture and Storage stochastic Monte Carlo model that has been tailored to reflect site-specific factors for emergency and remedial response actions. This estimation approach is consistent with the U.S. EPA's Underground Injection Control (UIC) Program's Class VI regulatory requirements and is intended to inform the face value of financial assurances for the Brown Pelican site. The estimation method is based on the peer-reviewed approach developed by the BRP Project's third-party consultants and has been used to inform estimation of coverage amounts for emergency and remedial response in previously approved Class VI permits. Specifically, the model's input parameters reflect the geologic location and specific chemical composition of the Project's CO₂ injectate stream, as well as site-specific conditions that exist within the established area of review. The analysis adopts several conservative input assumptions and incorporates probabilistic calculations that allow for multiple release

incidents across geologic sequestration activities – from injection through post-injection site care to site closure. The resulting coverage values are based on generally accepted response actions commonly used to respond to contamination incidents that could impair the public’s ability to safely access Underground Source(s) of Drinking Water (USDWs).

A stochastic model run of 50,000 Monte Carlo trials demonstrates that no events requiring ERR occur in 67.8% of the cases. In 26.1% of the trials, one event necessitating ERR action occurs. Three or more events necessitating ERR only occurred in 0.8% of the trials. The single most costly ERR event within any Monte Carlo trial was \$1.46 million in current dollars.

This upper-bound estimate reflects the Monte Carlo trial with the greatest estimate of emergency and remedial response cost for a single event out of the 50,000 trials run (comprising five separate ERR actions over the 62-year combined duration of injection and post-injection site care periods). The estimates specifically account for an array of possible risk events of potential concern at CCS sites, including undocumented deep well leaks, CO₂ injection well leaks, CO₂ monitoring well leaks, rapid leakage through the caprock, slow leakage through the caprock, releases through an existing fault, releases through an induced fault, leakage through caprock/faults then a shallow well and pipeline release events. These estimates are reasonable and appropriately conservative, in keeping with the recommendations set forth in EPA’s financial assurance guidance for Class VI wells.